

# Diaphragm Valve, Plastic

## Construction

The GEMÜ 690 2/2-way diaphragm valve has a low maintenance membrane actuator which can be controlled by inert gaseous media. Normally Closed, Normally Open and Double Acting control functions are available. All medium wetted parts and the actuator housing are made of plastic.

## Features

- Suitable for inert and corrosive\* liquid and gaseous media
- Valve body and diaphragm available in various materials and designs
- Insensitive to particulate media
- Various connections available
- Versions according to ATEX on request

## Advantages

- Optional flow direction, will seal in either flow direction up to full operating pressure
- Optional mounting position
- Body and diaphragm sizes have coordinated diameters, hence the fitting time is reduced because the pipe and fixing centres remain the same. Spares inventory is also reduced.
- Optional accessories
  - Electrical position indicator
  - Electrical position indicator with microswitches or proximity switches
  - NAMUR mounting bracket
  - Pneumatic or electro-pneumatic positioner
  - Stroke limiter (DN 65-100: observe marking on actuator cover)

\*see information on working medium on page 2



Sectional drawing

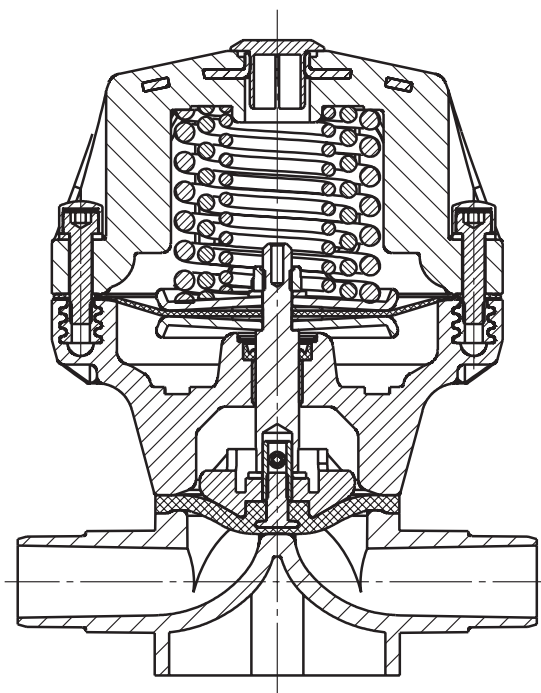

## Technical data

### Working medium

Corrosive, inert, gaseous and liquid media which have no negative impact on the physical and chemical properties of the body and diaphragm material.

### Ambient temperature

Valve body PVC-U	10 to 60 °C
Valve body PP / PP-H	5 to 60 °C
Valve body ABS / PVDF	-10 to 60 °C

### Working medium temperature

Valve body PVC-U	10 to 60 °C
Valve body ABS	-20 to 60 °C
Valve body PP / PP-H	5 to 80 °C
Valve body PVDF	-20 to 80 °C

The permissible operating pressure depends on the working medium temperature.

### Control medium

Inert gases	
Max. perm. temperature of control medium	40 °C
Filling volume (control function 1)	
DN 15 - 25	0.17 dm <sup>3</sup>
DN 32 - 40	0.38 dm <sup>3</sup>
DN 50	1.10 dm <sup>3</sup>
DN 65 - 100	2.50 dm <sup>3</sup>

### Pressure / temperature correlation for plastic

Temperature in °C (plastic body)		-20	-10	±0	5	10	20	25	30	40	50	60	70	80	
		Permissible operating pressure in bar													
Valve body material															
PVC-U	Code 1	-	-	-	-	10.0	10.0	10.0	8.0	6.0	3.5	1.5	-	-	
ABS	Code 4	10.0	10.0	10.0	10.0	10.0	10.0	10.0	8.0	6.0	4.0	2.0	-	-	
PP	Code 5	-	-	-	10.0	10.0	10.0	10.0	8.5	7.0	5.5	4.0	2.7	1.5	
PP-H	Code 71	-	-	-	10.0	10.0	10.0	10.0	8.5	7.0	5.5	4.0	2.7	1.5	
PVDF	Code 20	10.0	10.0	10.0	10.0	10.0	10.0	10.0	9.0	8.0	7.1	6.3	5.4	4.7	

Data for extended temperature ranges on request. Please note that the ambient temperature and medium temperature generate a combined temperature at the valve body which must not exceed the above values.

		Control function 1			Control function 2 and 3			Kv value [m <sup>3</sup> /h]
		Operating pressure [bar]		Control pressure [bar]	Operating pressure [bar]		Control pressure [bar]*	
MG	DN	EPDM / FPM	PTFE		EPDM / FPM	PTFE		
	15							5.6
25	20	0 - 10	0 - 6	5.5 - 7.0	0 - 10	0 - 6	max. 5.5 bar	8.2
	25							10.5
40	32	0 - 10	0 - 6	5.5 - 7.0	0 - 10	0 - 6	max. 5.5 bar	18.0
	40							25.0
50	50	0 - 10	0 - 6	5.5 - 7.0	0 - 10	0 - 6	max. 5.0 bar	46.0
80	65	0 - 8	0 - 6	5.0 - 7.0	0 - 8	0 - 6	max. 5.5 bar	78.0
	80							120.0
100	100	0 - 6	0 - 4	5.5 - 7.0	0 - 6	0 - 4	max. 5.5 bar	189.0

All pressures are gauge pressures. Operating pressure values were determined with static operating pressure applied on one side of a closed valve. Sealing at the valve seat and atmospheric sealing is ensured for the given values. Information on operating pressures applied on both sides and for high purity media on request. Kv values determined acc. to IEC 534 standard, inlet pressure 6 bar, Δp 1 bar, PVC-U valve body and soft elastomer diaphragm.

\*For required control pressure depending on operating pressure see diagram below.

MG = diaphragm size

### O-ring material for valve bodies with union ends

Diaphragm material	O-ring material
NBR	EPDM
FPM	FPM
EPDM	EPDM
PTFE	FPM
Other combinations on request	

### Control pressure characteristic DN 15 - 100 (EPDM, FPM)

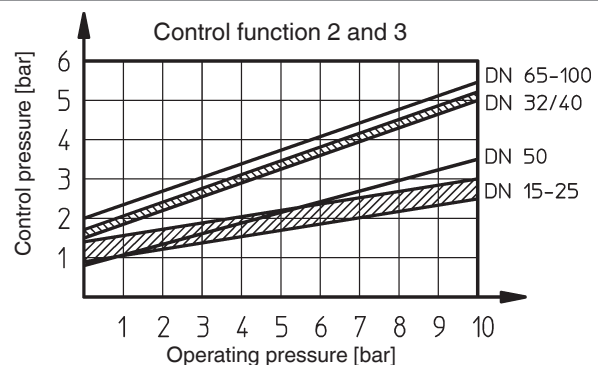

## Order data

Body configuration	Code
2/2-way body	D

Connection	Code
Spigots DIN for socket solvent cementing / welding	0
Flanges EN 1092 / PN10 / form B length EN 558, series 1 ISO 5752, basic series 1	4
Union ends with DIN insert (socket)	7
Spigots for IR butt welding	20
Spigots for IR butt welding, BCF	28
Spigots - inch	30
Union ends with inch insert (socket)	33
Flanges ANSI class 125/150 RF, length EN 558, series 1 ISO 5752, basic series 1	39
Union ends with DIN insert (for IR butt welding)	78

Valve body material	Code
PVC-U, grey	1
ABS	4
PP, reinforced	5
PVDF	20
Inliner PP-H grey / outliner PP reinforced	71

Diaphragm material		Code
NBR		2
FPM		4
EPDM		14
PTFE/EPDM, PTFE loose	MG 25 - 50	5E*
PTFE/EPDM, PTFE laminated	MG 25 - 100	52
PTFE/FPM, PTFE loose	MG 25 - 50	5F*
PTFE/FPM, PTFE laminated	MG 25 - 100	56

\* For use with valve bodies see page 8  
MG = diaphragm size

Control function		Code
Normally closed	(NC)	1
Normally open	(NO)	2
Double acting	(DA)	3

Bonnet version	Code
Diaphragm size 25	1/N
Diaphragm size 40	2/N
Diaphragm size 50	3/N
Diaphragm size 80	4/N
Diaphragm size 100	5/N

Order example	690	25	D	7	1	14	1	1/N
Type	690							
Nominal size		25						
Body configuration (code)			D					
Connection (code)				7				
Valve body material (code)					1			
Diaphragm material (code)						14		
Control function (code)							1	
Bonnet version (code)								1/N

## Actuator dimensions [mm]

### Control function 1

MG	DN	øB	A	A1	G	M
25	15 - 25	125	131	47	G 1/4	M16x1
40	32 - 40	155	177	75	G 1/4	M16x1
50	50	210	215	90	G 1/4	M16x1
80	65 - 80	260	280	127	G 1/4	M22x1,5
100	100	260	307	149	G 1/4	M22x1,5

MG = diaphragm size

### Control function 2 und 3

MG	DN	øB	A	A1	A2	G	M
25	15 - 25	125	98	47	27	G 1/4	M16x1
40	32 - 40	155	135	75	27	G 1/4	M16x1
50	50	210	164	90	29	G 1/4	M16x1
80	65 - 80	260	226	127	41	G 1/4	M22x1,5
100	100	260	263	149	46	G 1/4	M22x1,5

MG = diaphragm size

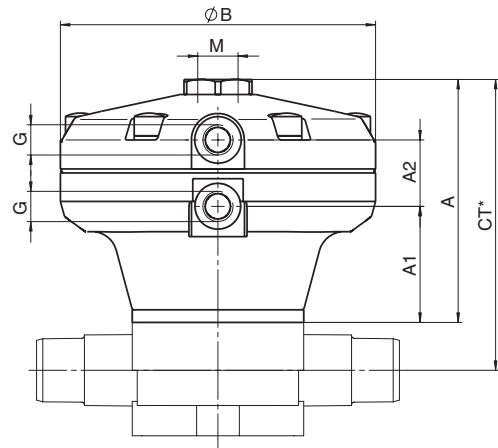
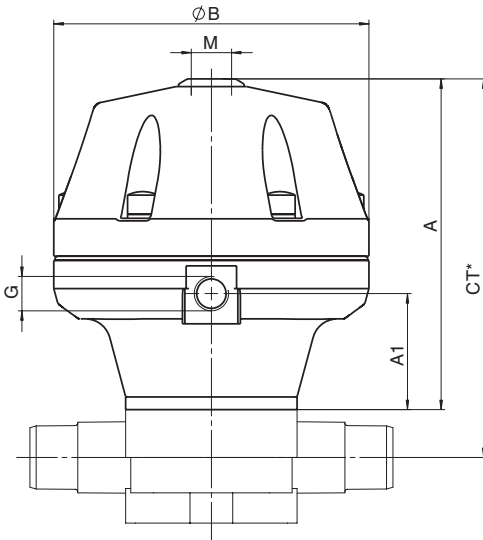

\* CT = A + H1 (see body dimensions)

### Valve body mounting dimensions [mm]

Diaphragm size	M	f
25	M6	25.0
40	M8	44.5
50	M8	44.5
80	M12	100.0
100	see drawing	

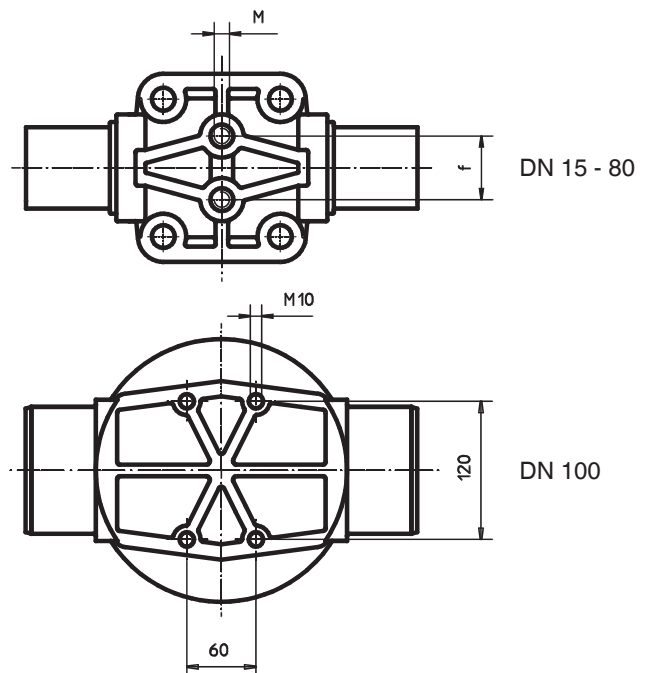

## Body dimensions [mm]

### Spigots - DIN, connection code 0

Valve body material: PVC-U (code 1), PP (code 5), PVDF (code 20), inliner PP-H (code 71)

MG	DN	NPS	L	H			H1			ød	c			Weight [kg]
				Material code 1	Material code 5	Material code 20, 71	Material code 1	Material code 5	Material code 20, 71		Material code 1	Material code 5	Material code 20, 71	
25	15	1/2"	124	45	-	50	19	-	24	20	16	-	18	0.24
	20	3/4"	144	45	-	50	19	-	24	25	19	-	19	0.24
	25	1"	154	45	-	50	19	-	24	32	22	-	22	0.34
40	32	1 1/4"	174	74	-	74	34	-	34	40	26	-	24	0.65
	40	1 1/2"	194	74	-	74	34	-	34	50	31	-	26	0.70
50	50	2"	224	78	-	82	38	-	42	63	39	-	29	1.10
80	65	2 1/2"	284	117	117	117	62	62	62	75	44	44	44	2.50
	80	3"	300	117	117	117	62	62	62	90	51	51	51	4.00
100	100	4"	340	140	140	140	75	75	75	110	61	61	61	4.40

For materials see overview on last page

MG = diaphragm size

### Spigots - inch, connection code 30

Valve body material: PVC-U (code 1), ABS (code 4)

MG	DN	NPS	L	H	H1	ød	c	Weight [kg]
25	15	1/2"	141	45	19	21.4	24	0.24
	20	3/4"	145	45	19	26.7	27	0.24
	25	1"	154	45	19	33.6	30	0.34
40	32	1 1/4"	174	74	34	42.2	33	0.65
	40	1 1/2"	194	74	34	48.3	39	0.70
50	50	2"	224	75	35	60.3	40	1.10
80	65	2 1/2"	284	117	62	73.1	44	2.50
	80	3"	300	117	62	88.9	51	4.00
100	100	4"	340	140	75	114.3	61	4.40

For materials see overview on last page

MG = diaphragm size

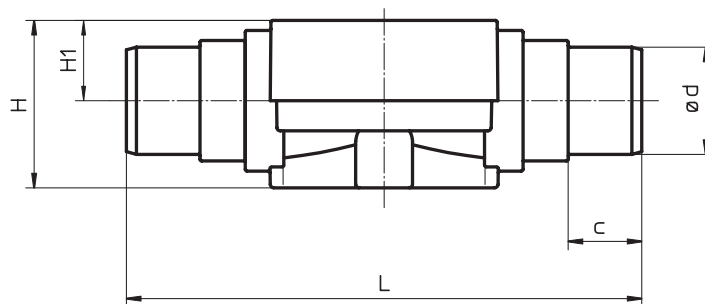

## Body dimensions [mm]

### Union ends with insert, connection code 7, 33 Valve body material: PVC-U (code 1), PVDF (code 20), inliner PP-H (code 71)

MG	DN	NPS	R	øD	L1	H	H1	Connection code 7			Connection code 33		Weight [kg]	
								L2			ød	L2		ød
								Material code 1	Material code 20	Material code 71				
25	15	1/2"	G 1	43	108	50	24	146	146	143	20	146	21.4	0.32
	20	3/4"	G 1 1/4	53	108	50	24	152	150	146	25	152	26.7	0.38
	25	1"	G 1 1/2	60	116	50	24	166	162	158	32	166	33.6	0.42
40	32	1 1/4"	G 2	74	134	74	34	192	184	181	40	192	42.2	0.88
	40	1 1/2"	G 2 1/4	83	154	74	34	222	210	207	50	222	48.3	0.97
50	50	2"	G 2 3/4	103	182	82	42	264	246	243	63	264	60.3	1.60

For materials see overview on last page

MG = diaphragm size

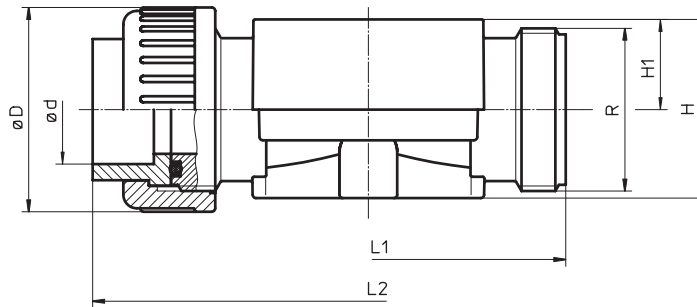

### Spigots for IR butt welding, connection code 20 Valve body material: PVDF (code 20), inliner PP-H (code 71)

MG	DN	L	H	H1	ød	s		c	Weight [kg]
						Material code 20	Material code 71		
25	15	154	50	24	20	-	1.9	33	0.18
	20	154	50	24	25	-	2.3	33	0.18
	25	154	50	24	32	-	2.9	33	0.18
40	32	194	74	34	40	-	3.7	33	0.43
	40	194	74	34	50	-	4.6	33	0.64
50	50	224	82	42	63	-	5.8	33	0.69
80	65	284	117	62	75	3.6	-	43	3.57
	80	300	117	62	90	4.3	-	51	3.30
100	100	340	140	75	110	5.3	-	59	4.00

For materials see overview on last page

MG = diaphragm size

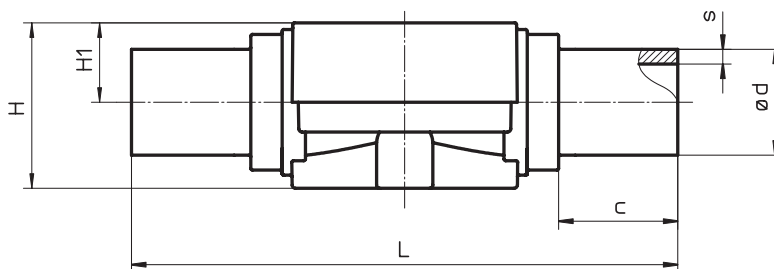

## Body dimensions [mm]

### Spigots for IR butt welding, BCF, connection code 28 Valve body material: PVDF (code 20)

MG	DN	L	H	H1	ød	c	c1	s	Weight [kg]
25	15	154	50	24	20	31	37	1.9	0.24
	20	154	50	24	25	31	37	1.9	0.25
	25	154	50	24	32	31	37	2.4	0.26
40	32	194	74	34	40	40	46	2.4	0.65
	40	194	74	34	50	40	46	3.0	0.66
50	50	224	82	42	63	40	46	3.0	1.10

MG = diaphragm size

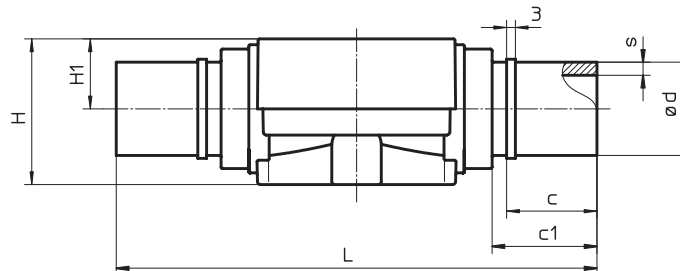

### Union ends with insert, connection code 78 Valve body material: PVDF (code 20), inliner PP-H (code 71)

MG	DN	L1	L2	H	H1	øD	ød	R	s		c	Weight [kg]
									Material code 20	Material code 71		
25	15	108	214	50	24	43	20	G 1	1.9	1.9	36	0.34
	20	108	220	50	24	53	25	G 1 1/4	1.9	2.3	37	0.39
	25	116	234	50	24	60	32	G 1 1/2	2.4	2.9	39	0.45
40	32	134	258	74	34	74	40	G 2	2.4	3.7	39	0.88
	40	154	284	74	34	83	50	G 2 1/4	3.0	4.6	43	1.10
50	50	182	318	82	42	103	63	G 2 3/4	3.0	5.8	43	1.70

For materials see overview on last page

MG = diaphragm size

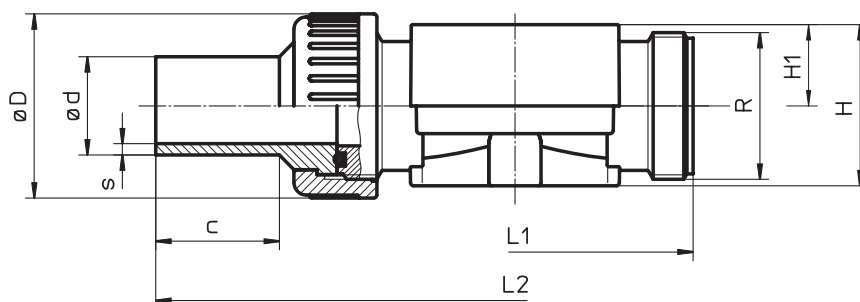

## Body dimensions [mm]

### Flanges, connection code 4, 39 Valve body material: PP (Code 5), PVDF (code 20), inliner PP-H (code 71)

MG	DN	FTF	H	H1	Connection code 4					Connection code 39					Weight [kg]		
					øD	øL	ød	øk	Number of bolts	øD	øL	ød	øk	Number of bolts			
Material code						5, 71	20					5, 71	20				
25	15	150*	depending on material code see body dimensions page 5 connection code 0	depending on material code see body dimensions page 5 connection code 0	95	14	45	45	65	4	95	16	45	45	60	4	0.73
	20	150			105	14	58	58	75	4	105	16	54	54	70	4	0.89
	25	160			115	14	68	68	85	4	115	16	63	63	79	4	1.30
40	32	180			140	18	78	78	100	4	140	16	73	73	89	4	2.10
	40	200			150	18	88	88	110	4	150	16	82	82	98	4	2.50
50	50	230			165	18	102	102	125	4	165	19	102	102	121	4	3.20
80	65	290			185	18	122	120	145	4	185	19	122	120	140	4	4.60
	80	310			200	18	138	125	160	8	200	19	133	125	152	4	6.70
100	100	350			220	18	158	150	180	8	229	19	158	150	190	8	8.20

For materials see overview below

MG = diaphragm size

\* Length is not according to EN 558 series 1

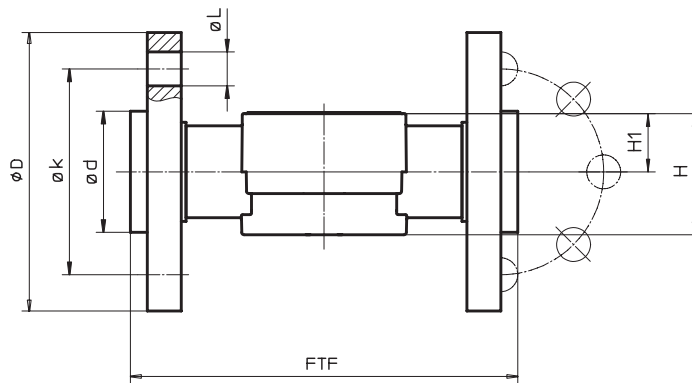

### Overview of valve bodies for GEMÜ 690

Connection code		0				4			7			20		28	30		33	39			78		
Material code		1	5	20	71	5	20	71	1	20	71	20	71	20	1	4	1	5	20	71	20	71	
MG	DN																						
25	15	X	-	X	X	-	X	X	X	X	X	-	X	X	X	X	X	-	X	X	X	X	
	20	X	-	X	X	-	X	X	X	X	X	-	X	X	X	X	X	-	X	X	X	X	
	25	X	-	X	X	-	X	X	X	X	X	-	X	X	X	X	X	-	X	X	X	X	
40	32	X	-	X	X	-	X	X	X	X	X	-	X	X	X	X	X	-	X	X	X	X	
	40	X	-	X	X	-	X	X	X	X	X	-	X	X	X	X	X	-	X	X	X	X	
50	50	X	-	X	X	-	X	X	X	X	X	-	X	X	X	X	X	-	X	X	X	X	
80	65	X*	X*	X*	-	X*	X*	-	-	-	-	X*	-	-	X*	X*	-	X*	X*	-	-	-	
	80	X*	X*	X*	-	X*	X*	-	-	-	-	X*	-	-	X*	X*	-	X*	X*	-	-	-	
100	100	X*	X*	X*	-	X*	X*	-	-	-	-	X*	-	-	X*	X*	-	X*	X*	-	-	-	

\* Valve bodies are not suitable for use with diaphragms code 5E and 5F

MG = diaphragm size

For further plastic diaphragm valves, accessories and other products, please see our Product Range catalogue and Price List. Contact GEMÜ.

**GEMÜ**® VALVES, MEASUREMENT AND CONTROL SYSTEMS

