



aerospace
climate control
electromechanical
filtration
fluid & gas handling
hydraulics
pneumatics
process control
sealing & shielding



Isys Micro

Plug-in valve island

PDE2597TCUK July 2011



ENGINEERING YOUR SUCCESS.

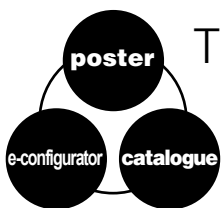

The machine designer Isys Micro workshop

Valves are the centre of electro-pneumatic automation. They are now designed into compact islands that are easily configured to each application.

For full efficiency in this enhanced automation practice, machine designers are helped by 3 complementary design tools :

- 1 - The Isys Micro valve island **e-configurator** and **3D models** are available on website:
<http://www.parker.com/pneu/isysmicro>
- 2 - The Isys Micro functional **poster**
- 3 - This **catalogue**, including technical data and ordering guide



Important !

Before carrying out any service work, ensure that the valve and manifold have been vented. Remove the primary supply air hose to ensure total disconnection of the air supply before dismantling valves or blank connection blocks.



NB !

All technical data in this catalogue is typical only. The air quality is decisive for the valve life: see ISO 8573.

WARNING

FAILURE OR IMPROPER SELECTION OR IMPROPER USE OF THE PRODUCTS AND/OR SYSTEMS DESCRIBED HEREIN OR RELATED ITEMS CAN CAUSE DEATH, PERSONAL INJURY AND PROPERTY DAMAGE.

This document and other information from Parker Hannifin Corporation, its subsidiaries and authorized distributors provide product and/or system options for further investigation by users having technical expertise. It is important that you analyze all aspects of your application and review the information concerning the product or system in the current product catalog. Due to the variety of operating conditions and applications for these products or systems, the user, through its own analysis and testing, is solely responsible for making the final selection of the products and systems and assuring that all performance, safety and warning requirements of the application are met. The products described herein, including without limitation, product features, specifications, designs, availability and pricing, are subject to change by Parker Hannifin Corporation and its subsidiaries at any time without notice.

SALE CONDITIONS

The items described in this document are available for sale by Parker Hannifin Corporation, its subsidiaries or its authorized distributors. Any sale contract entered into by Parker will be governed by the provisions stated in Parker's standard terms and conditions of sale (copy available upon request).

Pages

Intoduction

4 to 11

Product presentation

Ordering guide

12 to 25

Valve island components

Manifold components

14 & 15

Fittings and accessories

16 & 17

Isysnet components

Valve island end kits

18 & 19

Fieldbus & Industrial Ethernet modules, I/O modules and accessories

20 & 21

Valve Driver Module to TURCK BL67 adaptor

Valve Island end kits, 16 Outputs & Blank modules

22 & 23

Moduflex Bus components

Valve island, end kits, Fieldbus modules and accessories

24 & 25

Multi-pole connection components

Sub-D25 end kits and cables

26 & 27

Dimensions

28 to 31

Installation and Service

32 to 36

Valve Islands for centralized application

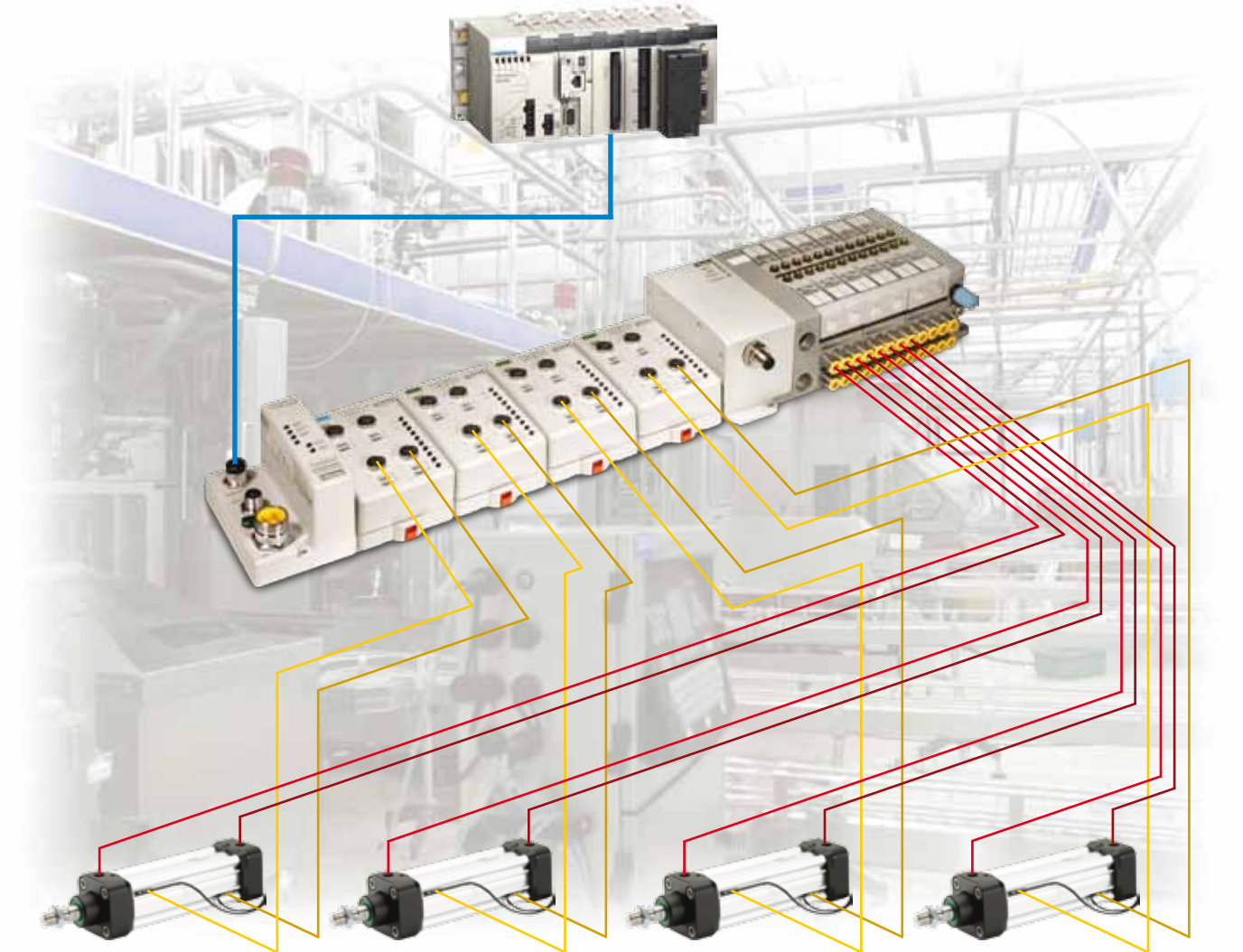

Valve islands for centralized application

Depending upon the machine configuration and design, all of the pneumatic actuators may be controlled from a centralized control panel complete with all the necessary pneumatic valves. The control valves would normally be grouped together into a 'valve island' enabling the solenoids to be electrically interconnected and in turn linked to a PLC via an industrial network. In this configuration all the sensors can be connected to either remote devices positioned around the machine or back to the centralized panel and signals transmitted to the PLC via the valve island and industrial network. Other digital or analogue I/O can be connected if required.

Valve Islands for decentralized application

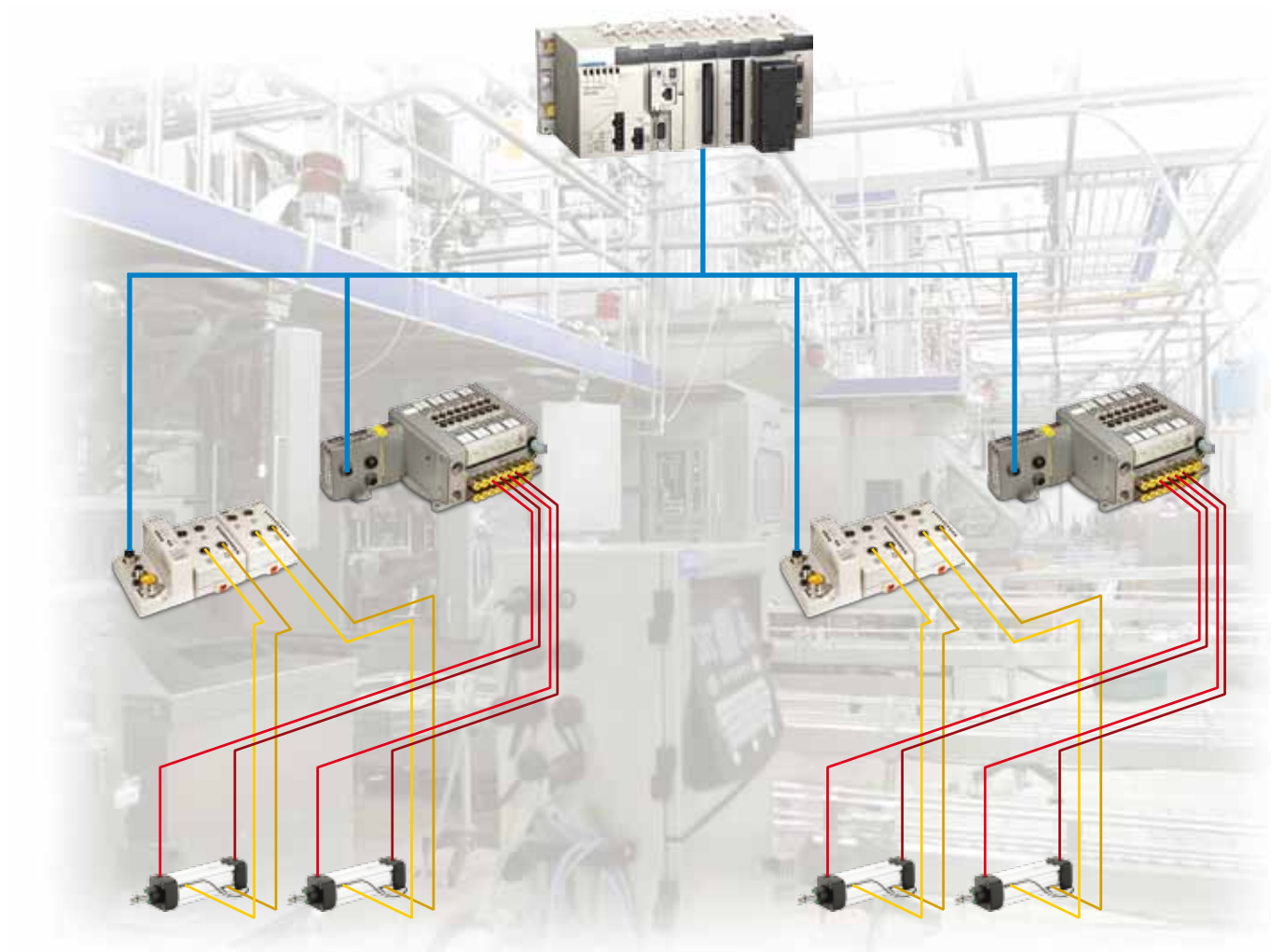

Valve islands for decentralized application

On larger machines where pneumatic actuators are distributed around the machine, a better solution may be to position smaller 'valve islands' closer to groups of actuators. This enables shorter runs of pneumatic tubing and can result in reduced air consumption and improved cycle times. Other digital or analogue I/O can be connected to the remote devices or directly to the PLC. All devices can be connected to the PLC using traditional wiring, multi-pole connection or an industrial network.

The Isys Micro valve redefines flexibility for pneumatic users. When either configured from basic components or ordered as pre-assembled and tested valve islands, Isys Micro valves are the answer to all your needs.



Solenoid operated Valve fitted with 24 VDC solenoids

Plug-in valves

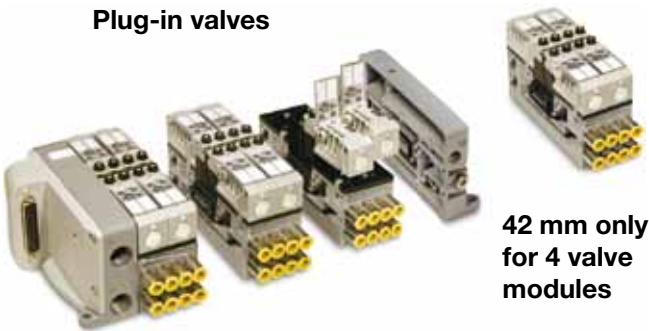

**42 mm only
 for 4 valve
 modules**

- Up to **8 pneumatic functions** on a **42 mm width** metal sub-base manifold.
- 4 valve modules **back to back** mounted for a compact design.
- Optimized flow with 6 mm OD tube allows 0,5 m/s speed on a 50 mm diameter cylinder with 1/4 fittings.

Optimized flow for a 6 mm OD tube

Qn = 282 NI/mn Qmax = 510 NI/mn

Side ported manifold design



- Manifold with common ducts for ports 1, 3 and 5, outlet port 2 and 4, and supply port for 12 and 14 are available side ported.

Bottom ported manifold design



- A bottom ported design for an easy integration into an enclosure.

An easy man-machine dialogue

• Multifunction manual override

Standard non-locking manual overrides can be easily changed to locking or blocked with accessories available with valves.

• Customer identification

Have your own identification on the product protected with a transparent flip-up cover.

A quick visual diagnostic face

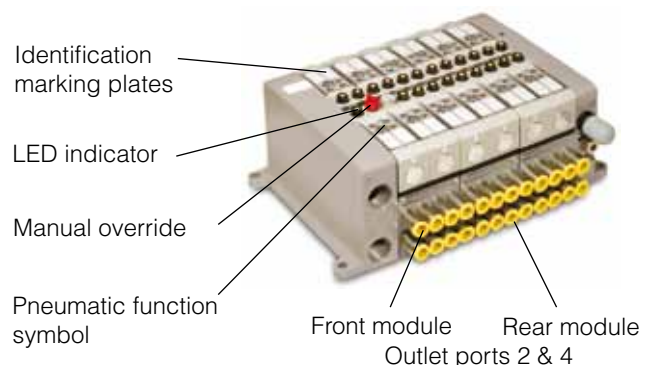

Isysnet : A centralized Fieldbus and Industrial Ethernet system

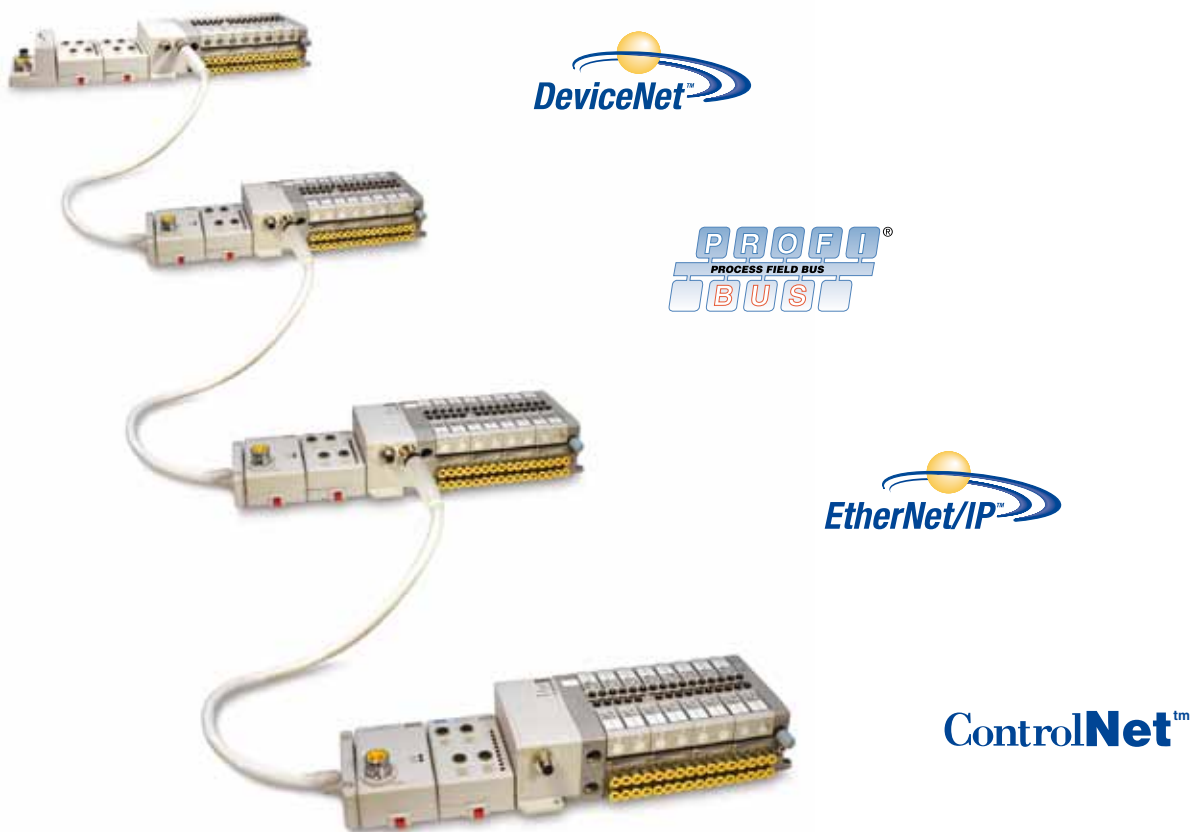

Integrated Solution

- A large Fieldbus and Industrial Ethernet communication offering for all Isys Micro range.
- Extremely fast I/O backplane uses change-of-state (COS) connections to maximise performance.
- UL, C-UL and CE certifications (as marked).

Modularity

- Ease of module replacement with unique latching mechanisms eliminating the need for screws.
- Auto Device Replacement allows OEMs to add I/O modules without making changes to the control software.
- Built-in panel grounding.
- Electronic and mechanical keying prevents users from placing I/O modules in the wrong sequence.

Communication Modules

- A Communication Module supports up to 63 I/O modules and up to 256 Inputs and 256 Outputs.

I/O Modules

- Accepts signals from sensors, photo eyes, limit switches and other field input devices.
- Provides signals to remotely operating solenoid valves and other field operating output devices.
- Choice of digital, analogue, high watt I/O Modules.
- Choose from a broad range of colour coded I/O types with connector choices of M8, M12 or M23.
- Built-in miswiring, short circuit, open circuit detection with electronic feedback.

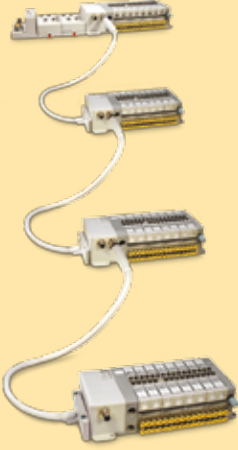

Flexible in use
 The Isys Micro range is fully dedicated to centralized applications where a high quantity of valves have to be concentrated in a single location.

Solenoid valve island can also be implemented with digital or analogical electrical I/O.

From a centralized application high complexity level to a basic configuration, with industrial communication or traditional multi-connection, an Isys Micro valve island can be designed.

One communication module for 256 Inputs and 256 Outputs

The combination of 32 output drivers and electrical I/O modules linked to the main communication module allows Isys Micro valve islands to drive up to 512 I/O, including up to 128 solenoids split between 4 interconnected devices.

Both electrical inputs and outputs modules can also be assembled either on the main or extended islands.

Expansion power supply may be used to provide additional Pointbus backplane current.

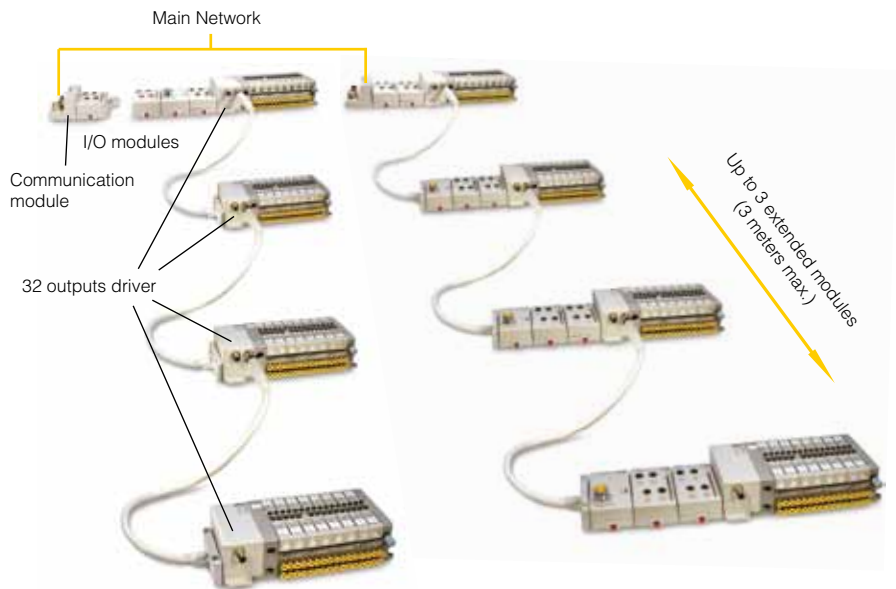

Up to 128 solenoid valves configuration

If a high quantity of valves is required in a centralized application, up to 3 extended islands can be connected to the main device communication module.

All extended islands are connected through a bus extension cable PSSVEXT1 (including 1 m cable and head plate).

In this configuration, the 32 outputs driver module, on the main island and the extended island, have to be equipped with a "bus extension" M12 connector, excepted for the last extended island.

All 32 outputs driver modules need to be equipped with a M12 solenoids power supply connector.

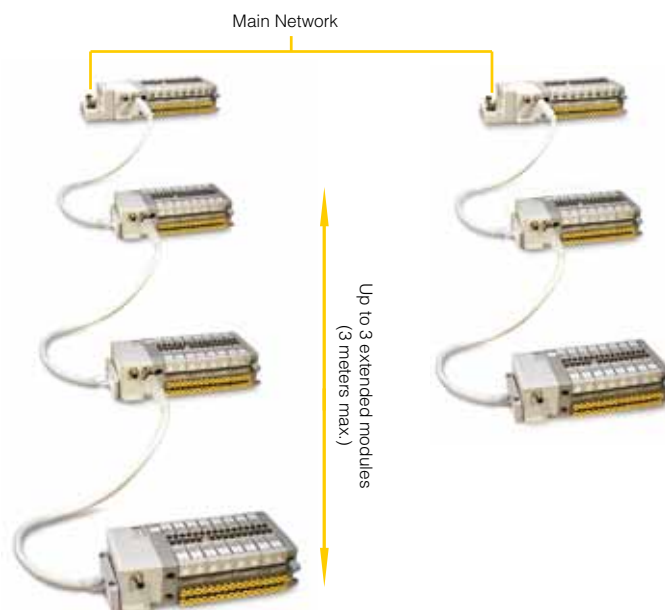

Up to 256 electrical outputs including 32 solenoid valves

Communication modules include a main 24 VDC power supply for the Bus and up to 10 digital or analogical output modules. Additional power supply is only requested if there are more than 11 output modules.

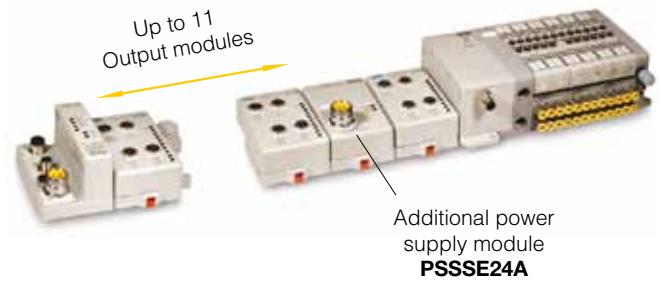

Up to 32 solenoid valves

Communication modules include a main 24 VDC power supply for the bus and the 32 output driver modules. All solenoids can be energized at the same time.



Island up to 16 or 32 solenoid valves linked to the Turck BL67 remote I/O device series

 This electro-mechanical interface allows, with its modularity up to 16 or 32 solenoid valves, an inter-connection to the TURCK BL67 Series, offering a wide choice of industrial communication with Field bus and Industrial Ethernet protocols and a complete range of electrical I/O modules.



Island for fieldbus communication in decentralized application

In a decentralized application where a serial communication is required and only a few valves are necessary, different fieldbus protocol modules are also available.

In that case, the valve island has to be equipped with a bus communication head module adaptor.

Depending on the protocol, the head module can pilot up to 16 solenoid valves.



Island with multi-pole connection

In a decentralized application, when a multi-pole connection is required, the valve island head module can be equipped with a standard Sub-D25 connector.

With this Sub-D25 connection, up to 24 solenoid valves can be piloted.



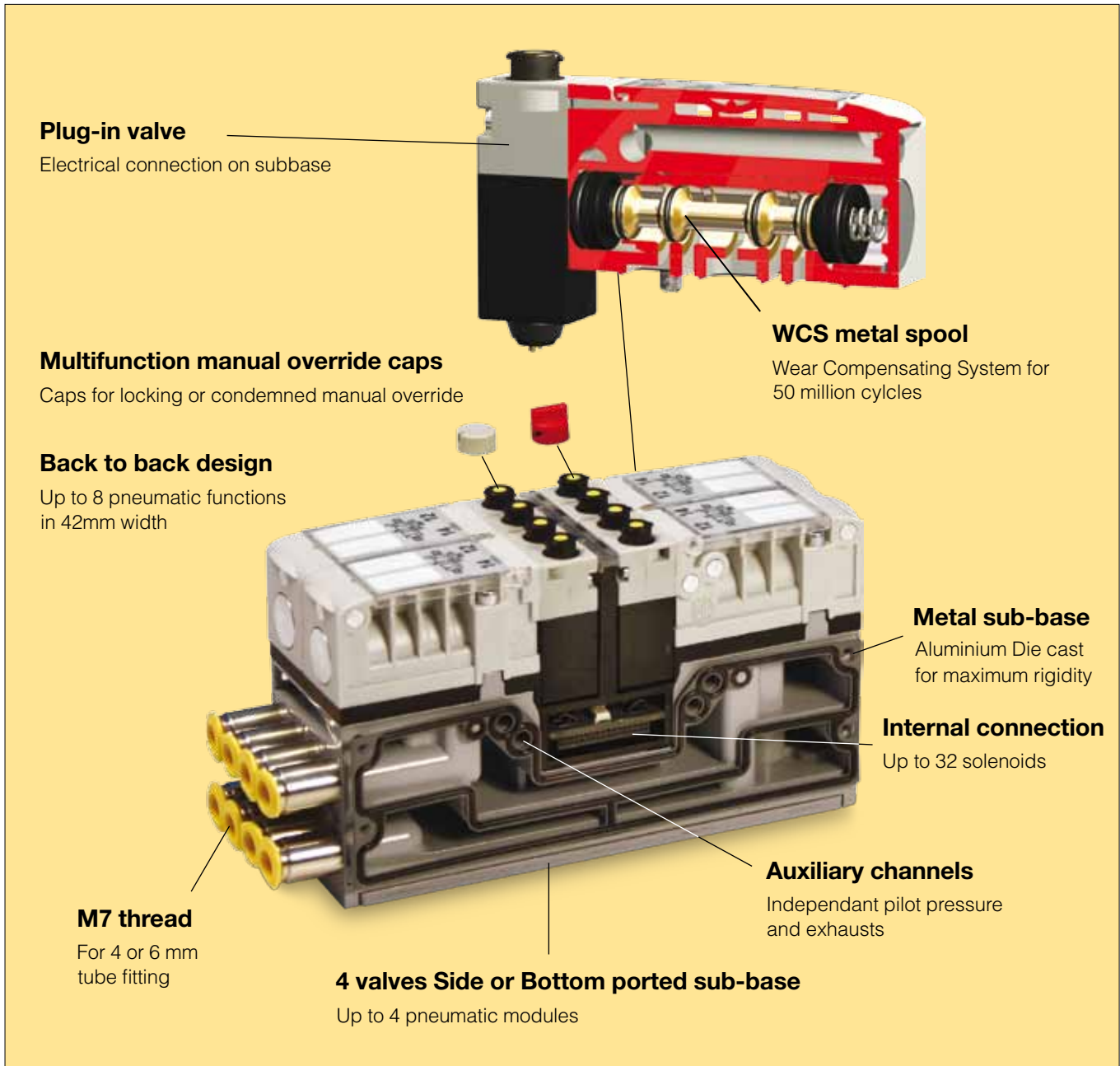

Material Specification

Valve spool :	Brass
Valve spool enclosure :	Brass
Dynamic seals :	Nitrile
Valve body :	Polyamide reinforced fibreglass
Seals :	Nitrile
Springs :	Stainless steel
Top cover :	Polyester
Subbase - End plates :	Painted aluminium

Certification

EMC / CE mark. :	According to EN 61 000-6-2
Dust & water protection :	IP65 according to EN 60529

Flow Characteristics

Dual 3/2

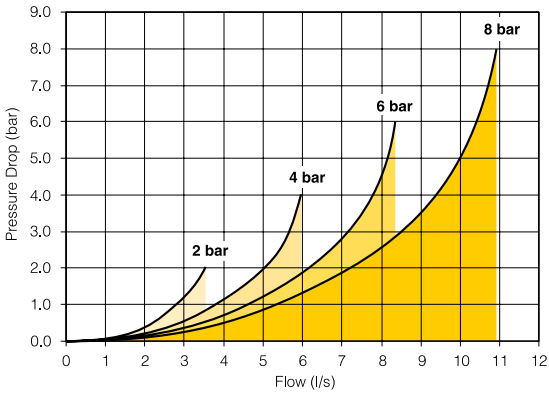

Operating pressure :	2,7 to 8,3 bar
Change-over time (side 14)	Actua. 15 ms Return 20 ms P = 6b
Change-over time (side 12)	15 ms / 25 ms P = 6b
Flow (acc. to ISO 6358) :	c = 1,2 NI/s x bar b = 0,13 Qn = 4,6 NI/s Qmax = 8,4 NI/s

5/2 single and double solenoid

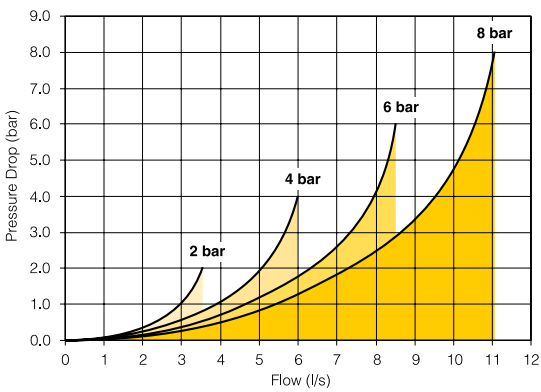

Operating pressure single solenoid:	2,7 to 8,3 bar
Operating pressure double solenoid:	1,7 to 8,3 bar
Change-over time single solenoid:	Actua. 15 ms Return 25 ms P = 6b
Change-over time double solenoid:	13 ms / 13 ms P = 6b
Flow (acc. to ISO 6358) :	c = 1,2 NI/s x bar b = 0,13 Qn = 4,7 NI/s Qmax = 8,5 NI/s

5/3 all ports blocked

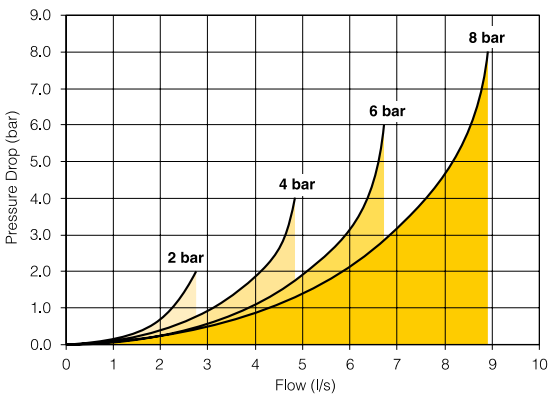

Operating pressure :	2,7 to 8,3 bar
Change-over time	Actua. 20 ms Return 20 ms P = 6b
Flow (acc. to ISO 6358) :	c = 1 NI/s x bar b = 0,14 Qn = 3,8 NI/s Qmax = 6,7 NI/s

Characteristics

Fluid :	Air or inert gas Filtered 40 μ Class 5 (according to ISO 8573-1)	Operating pressure :	-0.9 to 8,3 bar with external pressure 6 bar
Storage temperature :	-40 °C to + 70 °C	Piloting pressure :	2.7 to 8.3 bar
Working temperature :	-15 °C to + 50°C	Exhaust collection :	Independant exhaust collection
Vibration :	according to IEC 68-2-6 2G to 150 Hz	Rated coil voltage :	24 VDC -15 % / +10 %
Shock :	according to IEC 68-2-27 15G 11 ms	Electrical connection:	Not polarised
		Coil insulation :	Class B
		Power consumption :	1 W (42 mA) with LED
		Duty factor :	100 % at 20°C



Build your device configuration

Valve island components

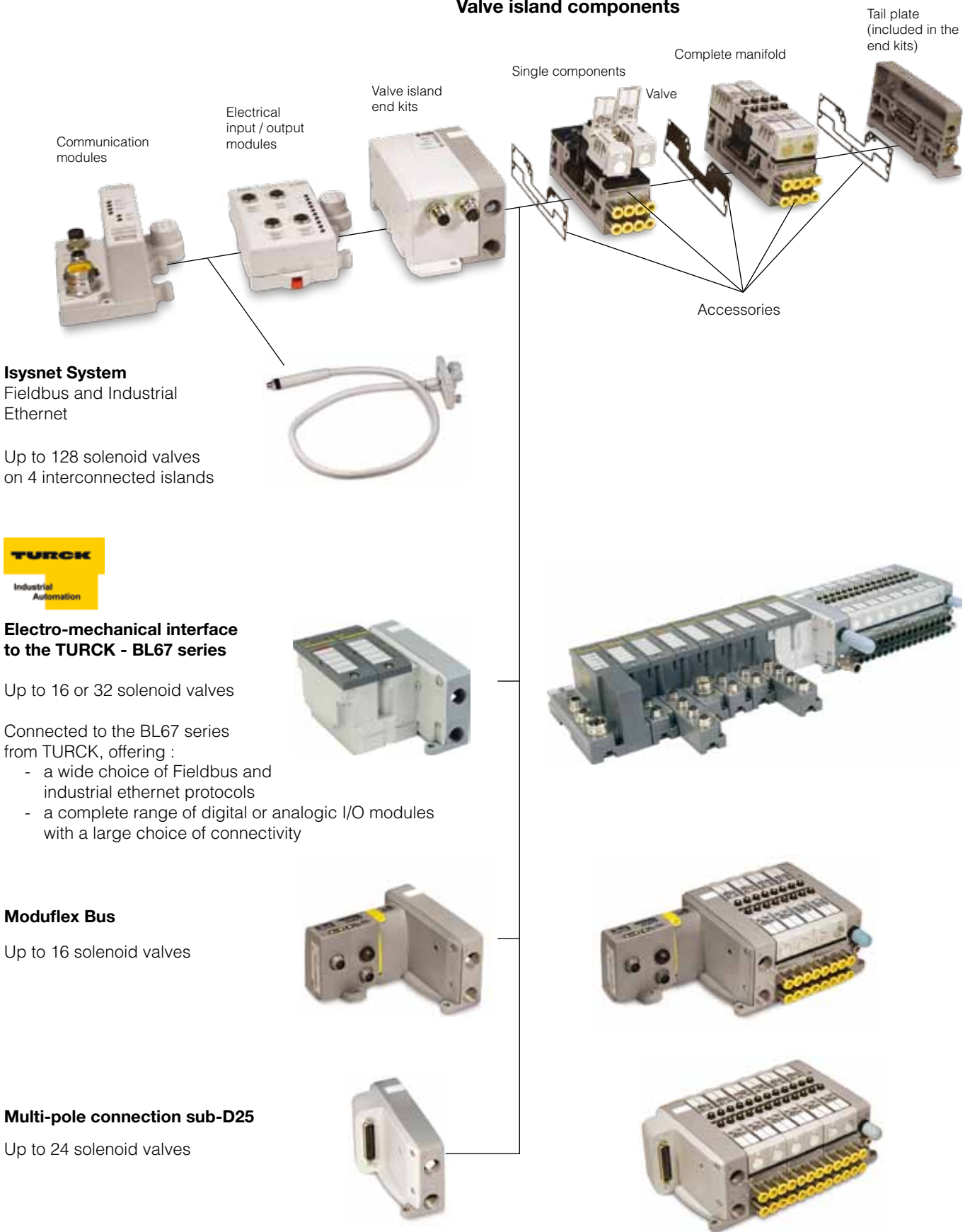

Valve island components

Manifold components:

Pages 14 & 15



Valve



Sub-base



Complete manifold

Fittings and accessories:

Pages 16 & 17



Fittings



Multi-pressure manifold seals

Isysnet components

Valve island end kits, Fieldbus & Industrial Ethernet modules, I/O modules and accessories:

Pages 18 & 19



32 outputs drivers



Industrial communication modules



Bus extender



I/O modules



Accessories

Valve Driver Module to TURCK BL67 adaptor

Valve island end kits, 16 outputs & Blank modules:

Pages 22 & 23



16 or 32 Outputs drivers



16 Output or Blank modules

Moduflex Bus components

Valve island end kits, Fieldbus modules and accessories:

Pages 24 & 25



Fieldbus module



Fieldbus adaptor



Accessories

Multi-pole connection components

Sub-D25 end kits and cables:

Pages 26 & 27



Sub-D25 end kits



Cables

Valve ordering chart

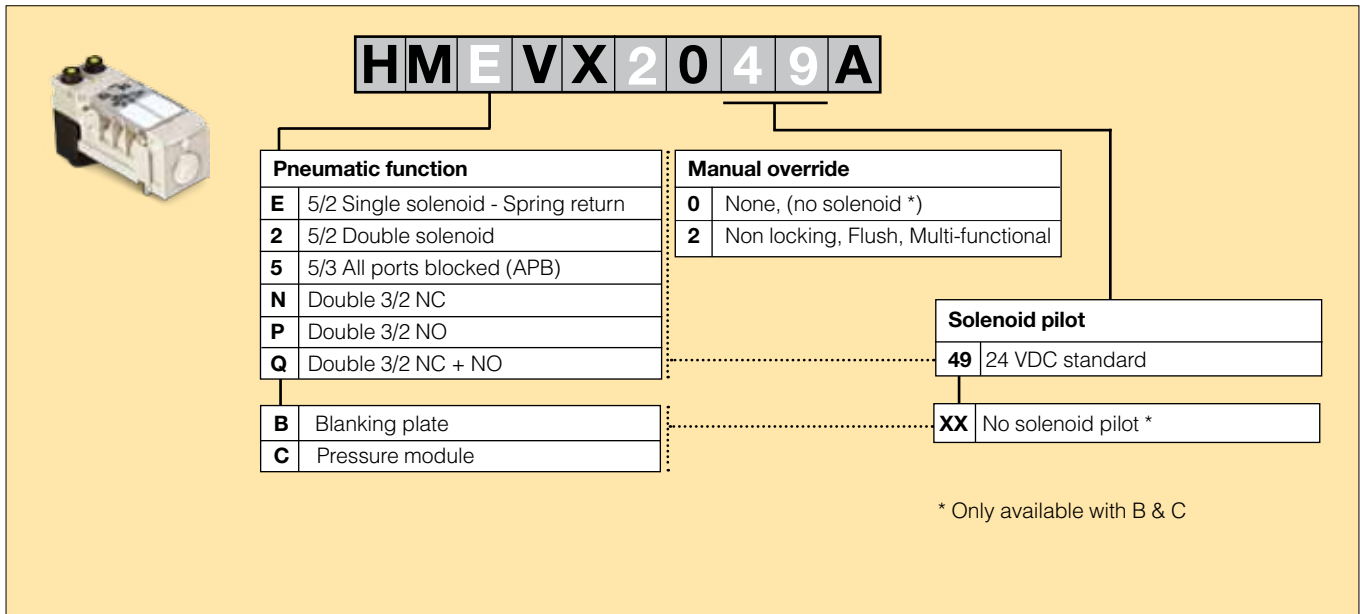

HMEVX2049A

Pneumatic function		Manual override	
E	5/2 Single solenoid - Spring return	0	None, (no solenoid *)
2	5/2 Double solenoid	2	Non locking, Flush, Multi-functional
5	5/3 All ports blocked (APB)		
N	Double 3/2 NC		
P	Double 3/2 NO		
Q	Double 3/2 NC + NO		

Solenoid pilot	
49	24 VDC standard
XX	No solenoid pilot *

B	Blanking plate
C	Pressure module

* Only available with B & C

Manifold ordering chart (without valve module and fitting)

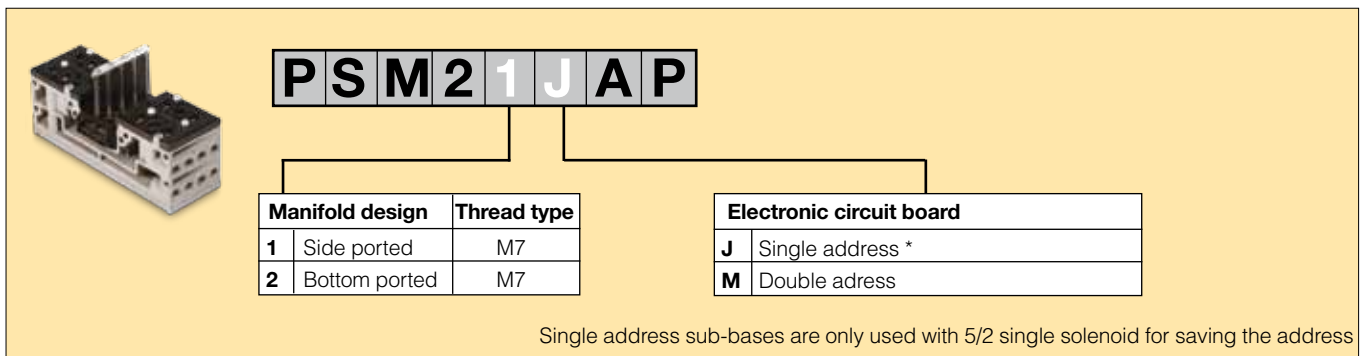

PSM21JAP

Manifold design	Thread type
1	Side ported M7
2	Bottom ported M7

Electronic circuit board	
J	Single address *
M	Double address

Single address sub-bases are only used with 5/2 single solenoid for saving the address

Manifold ordering chart (complete with valve modules and/or fittings)

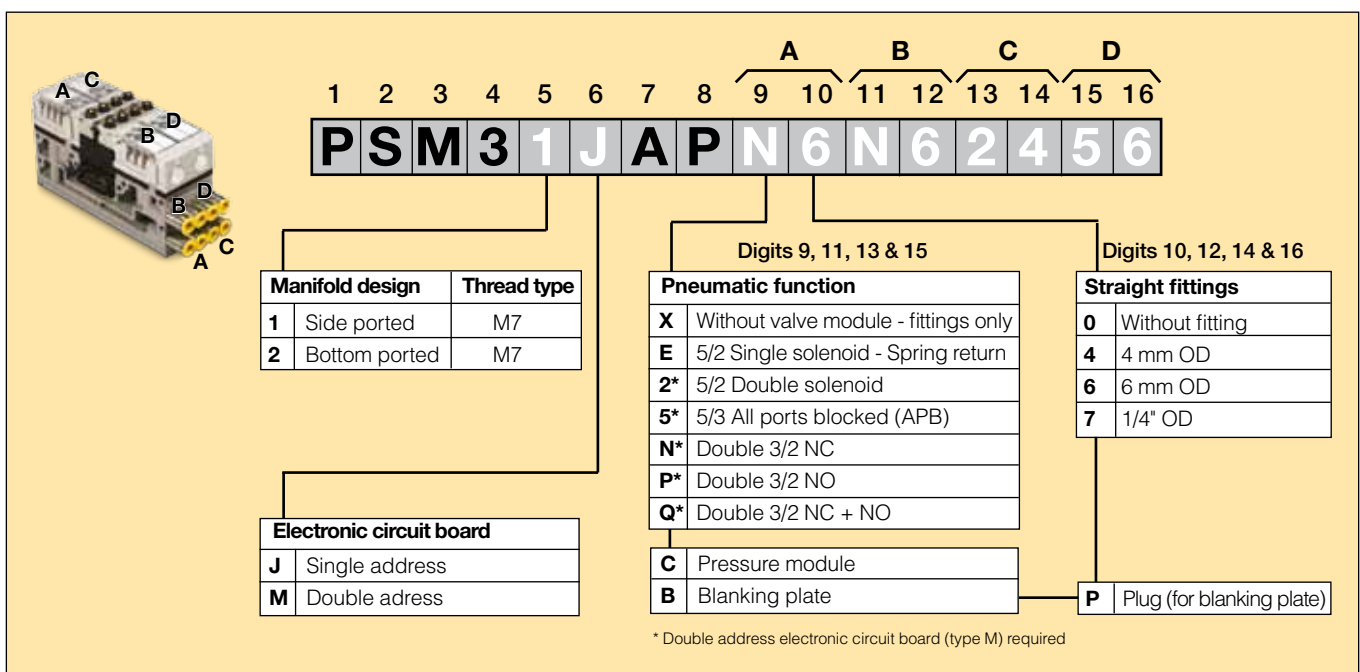

PSM31JAPN6N62456

Manifold design	Thread type
1	Side ported M7
2	Bottom ported M7

Electronic circuit board	
J	Single address
M	Double address











Pneumatic function	
X	Without valve module - fittings only
E	5/2 Single solenoid - Spring return
2*	5/2 Double solenoid
5*	5/3 All ports blocked (APB)
N*	Double 3/2 NC
P*	Double 3/2 NO
Q*	Double 3/2 NC + NO

Straight fittings	
0	Without fitting
4	4 mm OD
6	6 mm OD
7	1/4" OD



C	Pressure module
B	Blanking plate
P	Plug (for blanking plate)

* Double address electronic circuit board (type M) required











Solenoid operated valve fitted with 24 VDC solenoid

	Symbol	Description	Weight (g)	Order code
 <p>Including multi-function manual override cap</p>		Double 3/2 NC + NC	60	HMNVX2049A
		Double 3/2 NO + NO	60	HMPVX2049A
		Double 3/2 NC + NO	60	HMQVX2049A
		5/2 single solenoid - Spring return	49	HMEVX2049A
		5/2 double solenoid	60	HM2VX2049A
		5/3 all ports blocked (APB)	65	HM5VX2049A
		Blanking module kit (including two M7 plugs for manifold)	30	HMBVX00XXA
		Additional pressure module	30	HMCVX00XXA

Metal manifold for 4 valves (M7 threaded)

	Description	Weight (g)	Order code
 <p>Side ported</p>	4 position manifold single electrical address	332	PSM21JAP
	4 position manifold double electrical address	332	PSM21MAP
 <p>Bottom ported</p>	4 position manifold single electrical address	310	PSM22JAP
	4 position manifold double electrical address	310	PSM22MAP

Complete manifold without fitting (M7 threaded)

	Symbol	Description	Weight (g)	Order code
 <p>Side ported</p>		4 x Double 3/2 NC + NC	572	PSM31MAPN0N0N0N0
		4 x 5/2 single solenoid - Spring return	528	PSM31JAPE0E0E0E0
		4 x 5/2 double solenoid	572	PSM31MAP20202020
		4 x 5/3 all ports blocked (APB)	592	PSM31MAP50505050
 <p>Bottom ported</p>		4 x Double 3/2 NC + NC	550	PSM32MAPN0N0N0N0
		4 x 5/2 single solenoid - Spring return	506	PSM32JAPE0E0E0E0
		4 x 5/2 double solenoid	550	PSM32MAP20202020
		4 x 5/3 all ports blocked (APB)	570	PSM32MAP50505050

Multi-pressure Manifold with blocking plates

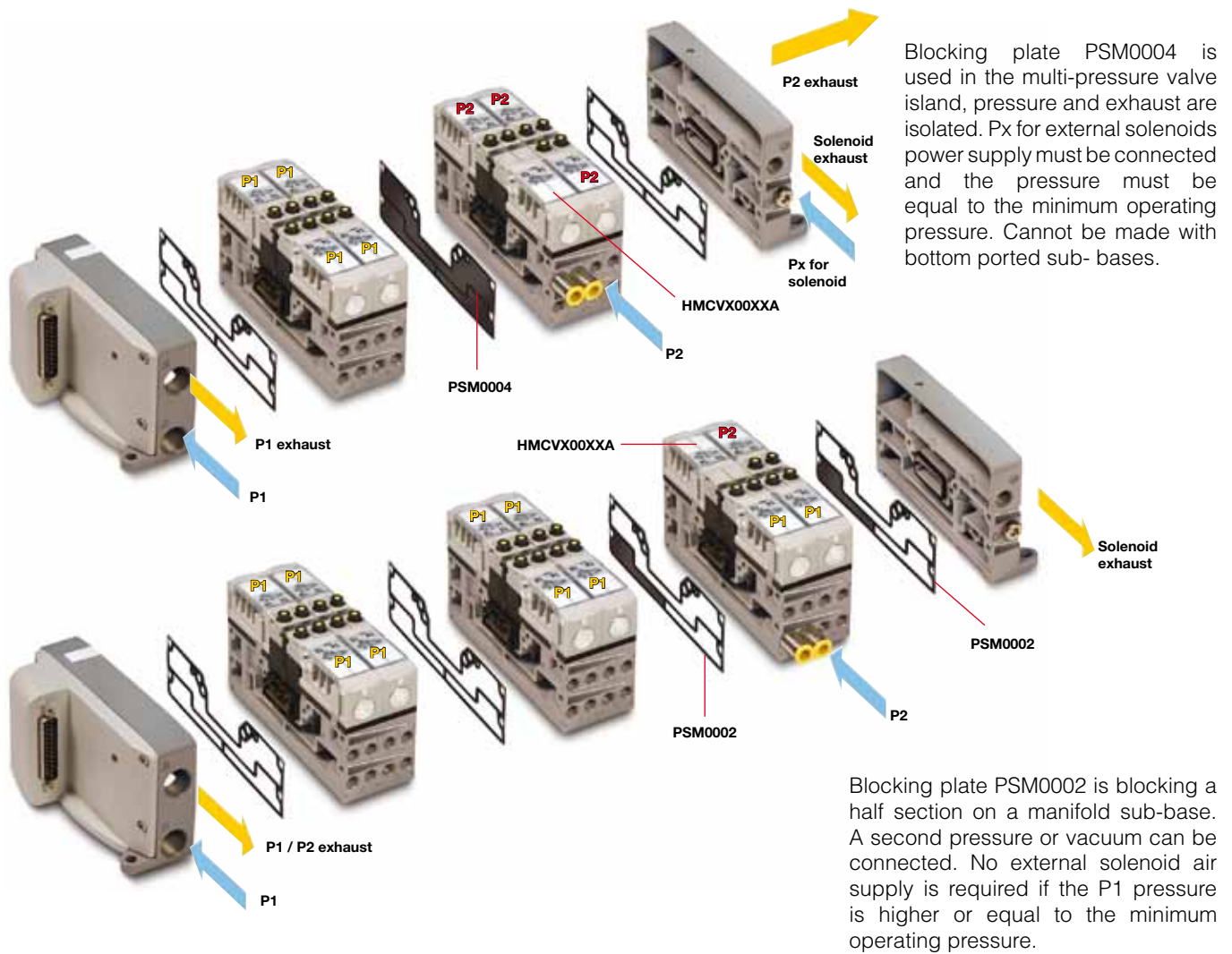



Auxiliary pressure for solenoid pilots and Exhaust channel

All end plates are delivered with an internal solenoid power supply version and can be easily changed to external solenoid power supply by simply moving a plug, if the main pressure is below the minimum operating pressure.

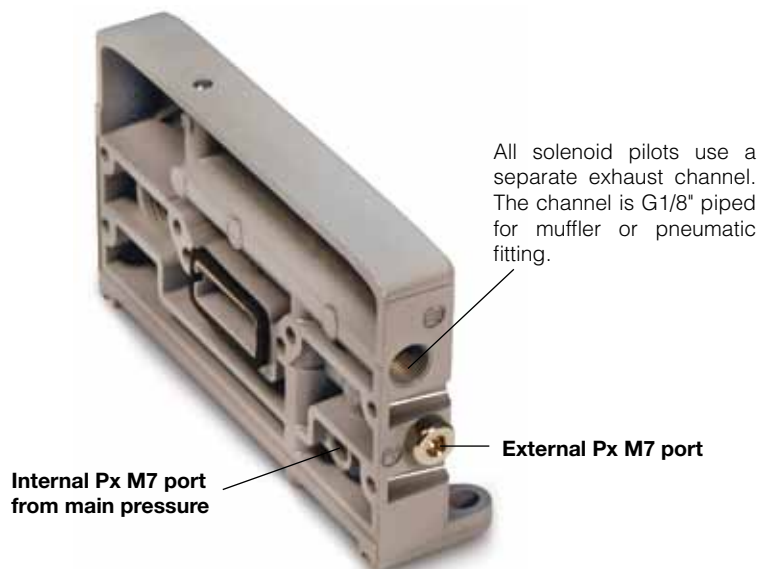
Auxiliary pressure supply port for solenoid pilot : This is a M7 port. The internal pilot supply end plate version includes an M7 plug. To change from internal supply to external supply mode, remove the plug and screw it into the internal Px port.



Pneumatic accessories

	Description	Size	Tube OD	Material	Order code
	Straight pneumatic connector for sub-base and Px	M7	4 mm	Metal	F28PMB4M7MD
		M7	6 mm	Metal	F28PMB6M7MD
	Straight pneumatic connector for Ex	1/8"	6 mm	Metal	F4PMB6-1/8
		3/8"	8 mm	Metal	F4PB8-3/8
		3/8"	10 mm	Metal	F4PB10-3/8
Straight pneumatic connector for Pressure and Exhaust ports	3/8"	12 mm	Metal	F4PB12-3/8	
	Muffler for Ex	1/8"		Metal	ESB12MC
		1/8"		Plastic	P6M-PAB1
	Muffler for exhaust port	3/8"		Sintered metal	9090050900

Multi-pressure inter-manifold seal plate

	Description	Pressure port	Exhaust port	Weight (g)	Order code
	Inter-manifold seal plate	Passing / Passing	Passing	16	PSM0001
		Passing / Block	Passing	20	PSM0002
		Passing / Block	Block	30	PSM0003
		Block / Block	Block	40	PSM0004

Spare parts

	Description	Weight (g)	Order code
	24 VDC Pilot solenoid with screws	11	PSM0010
	Set of 10 multifunction manual override caps	15	PSM0011
	Set of 5 valve manifold gaskets and 10 screws	25	PSM0012
	Set of 10 M7 plugs for auxiliary pressure selection	30	PSM0013
	Set of 10 labels (in the P/N, x has to be replaced with the valve function letter, see page 14)	5	PSM002x
	Set of 10 manifold to manifold M3 screws	20	PSM0014

Isysnet 32 output driver end modules ordering chart



P S M L 6 1 A P

ISYSNET 32 Output driver end modules		
	24 VDC power supply connector	Extender bus connector
L6	NO	NO
M5	NO	YES
M6	YES	NO
M7	YES	YES

	Ported design	Thread type
1	Side ported	3/8" BSPP
2	Bottom ported	3/8" BSPP
5	Side ported	3/8" NPT
6	Bottom ported	3/8" NPT

32 outputs driver selection guide :

L6 type

- Isysnet 32 outputs driver with internal solenoids power supply from the communication head module
- Extended valve island not possible



Up to 32 solenoid valves per island

M6 type

- Isysnet 32 outputs driver with external solenoids power supply by M12 male connector
- Extended valve island not possible



Up to 32 solenoid valves per island

M7 type

- Isysnet 32 outputs driver with external solenoids power supply by separated M12 male connector
- Extended Bus link connection for additional valve islands by separate M12 female connector



Up to 32 solenoid valves per island

M5 type

- Isysnet 32 outputs driver with internal solenoids power supply from the communication head module
- Extended Bus link connection for additional valve islands by separate M12 female connector



Up to 32 solenoid valves per island

Isysnet bus extender

Isysnet bus extender communication 1 meter cable for instant valve island plug-in by M12 male connector and direct head connection plate on Isysnet device

Every extended island has to be separately power supplied

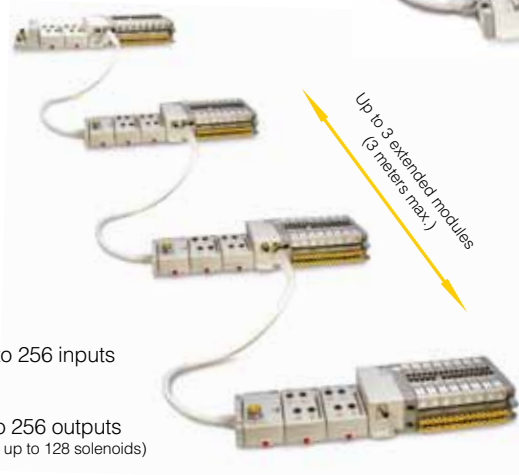

Up to 3 extended modules
(3 meters max.)

Up to 256 inputs





Up to 256 outputs
(including up to 128 solenoids)

Technical data

Isysnet 32 Outputs driver modules

- Number of Outputs : 32
- Operating Voltage Range : 20,4 to 26.4 VDC
- Output current rating Nom. : 50 mA per channel (100 mA Max)
3.2A per module
- Pointbus current : 200 mA
- Working temperature : -15°C to 50°C
- Dust and water protection : IP65

Isysnet 32 outputs driver modules

	Sub-base design	Thread type	24 VDC power supply	Extender bus	Weight (g)	Order code
	Side ported	3/8" BSPP	NO	NO	400	PSML61AP
	Bottom ported	3/8" BSPP	NO	NO	400	PSML62AP
	Side ported	3/8" BSPP	YES	NO	400	PSMM61AP
	Bottom ported	3/8" BSPP	YES	NO	400	PSMM62AP
	Side ported	3/8" BSPP	NO	YES	400	PSMM51AP
	Bottom ported	3/8" BSPP	NO	YES	400	PSMM52AP
	Side ported	3/8" BSPP	YES	YES	400	PSMM71AP
	Bottom ported	3/8" BSPP	YES	YES	400	PSMM72AP

Isysnet bus extender

	Description	Weight (g)	Order code
	Head plate 1 meter cable / M12 male connector for extended island inter-connection	380	PSSVEXT1

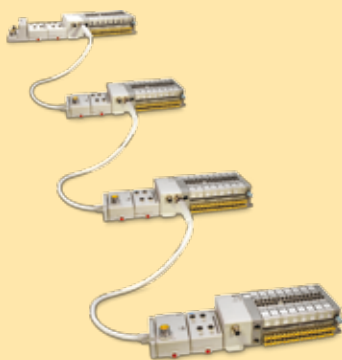

Communication modules :

- Fieldbus
- Industrial Ethernet

Digital and Analogical I/O modules
Extended power supply module
IP67 modules

Isysnet Communication and I/O modules

Isysnet Communication modules

Isysnet communication modules are available in :

- DeviceNet
- Profibus DP
- Ethernet I/P
- ControlNet



Digital or Analogical electrical I/O modules

Some modules have diagnostic features, electronic fusing, or individually isolated inputs/outputs. The Isysnet family provides a wide range of input and output modules to span many applications, from highspeed discrete to process control. Isysnet supports producer/consumer technology, which allows input information and output status to be shared among multiple Logix controllers.



Isysnet Extension Power Unit

The auxiliary power supports up to 10 I/O modules and 32 output driver with a maximum of 10 A field power. The 24 VDC extension power unit (PSSSE24A) extends the backplane bus power to support up to 10 more I/O modules. Connect additional extension power units to expand the I/O assembly up to 63 I/O modules

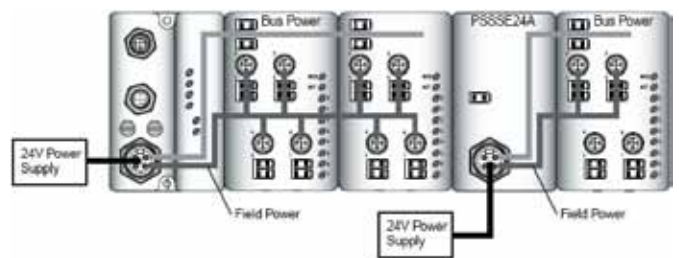

Technical data

Isysnet Communication modules & Extension power unit

Bus power supply : 24 VDC at 400 mA
Power supply input voltage : 24 VDC
Operative voltage range : 10 to 28.8 VDC
Input overvoltage protection : Reverse polarity protected

Isysnet Analogue Input modules

Number of Outputs : 2
Input signal Range : 4 to 20 mA / 0 to 10 VDC
Pointbus current : 75 mA

Isysnet Analogue Output modules

Number of Outputs : 2
Input signal Range : 4 to 20 mA / 0 to 10 VDC
Pointbus current : 75 mA

Isysnet Digital Input modules

Number of Outputs : 8 – PNP or NPN
Operating Voltage Range : 10 to 28.8 VDC
Input current on-state : 2 to 5 mA
Input current off-state : 1,5 mA
Pointbus current : 75 mA

Isysnet Digital Output modules

Number of Outputs : 8
Operating Voltage Range : 10 to 28.8 VDC
Output current rating Max. : 1 A per channel
3 A per module
Pointbus current : 75 mA







Isysnet Relay Output modules

Number of Outputs : 4 – NO contacts
Operating Voltage Range : 5 to 28.8 VDC
Output current rating Max. : 2 A per channel
8 A per module
Pointbus current : 90 mA

Isysnet communication modules

	Description	Fieldbus connection	Power supply connector	Weight (g)	Order code
	DeviceNet	M18	7/8" - 4 pins	400	PSSCDM18PA
		M12 - A coding	7/8" - 4 pins	400	PSSCDM12A
	Profibus DP	M12 - B coding	7/8" - 5 pins	380	PSSCPBA
	Ethernet I/P	M12 - D coding	7/8" - 4 pins	380	PSSCENA
	ControlNet	M12 - D coding	7/8" - 4 pins	380	PSSCCNA



Isysnet electrical I/O modules

	Description	Polarity	Connector type	Weight (g)	Order code
	8 Digital Inputs	PNP	8 x M8	400	PSSN8M8A
			4 x M12	380	PSSN8M12A
	8 Digital Outputs	NPN	8 x M8	400	PSSP8M8A
			4 x M12	380	PSSP8M12A
	8 Digital Outputs	PNP	8 x M8	400	PSST8M8A
			4 x M12	380	PSST8M12A
	8 Digital Outputs	PNP	1 x M23	400	PSST8M23A
			4 x M12	380	PSST8M12A
	4 Digital Outputs	Relay	4 x M12	410	PSSTR4M12A
	2 Analogue Inputs	0 - 10 V	2 x M12	400	PSSNAVM12A
	2 Analogue Outputs	4 - 20 mA	2 x M12	400	PSSNACM12A
		0 - 10 V	2x M12	400	PSSTAVM12A
	2 Analogue Outputs	4 - 20 mA	2 x M12	400	PSSTACM12A
		0 - 10 V	2 x M12	400	PSSTACM12A





Isysnet auxiliary electrical modules

	Description	Connector type	Weight (g)	Order code
	24 VDC expansion power unit	7/8" - 4 pins	420	PSSSE24A

Isysnet bus extender

	Description	Length	Weight (g)	Order code
	Bus extender cable for Isysnet module interconnection	1 meter	380	PSSEXT1
		3 meters	760	PSSEXT3
	Isysnet termination module		200	PSSTERM

Isysnet accessories

	Description	Bus protocol	Connector type	Weight (g)	Order code
	Power supply connector	DeviceNet, ControlNet & Ethernet	7/8" - 4 pins	40	P8CS7804AA
		Profibus DP	7/8" - 5 pins	40	P8CS7805AA
	Line termination	DeviceNet	M12 - A coding	25	P8BPA00MA
		Profibus DP	M12 - B coding	25	P8BPA00MB
	Bus IN female connector	DeviceNet	M12 - A coding	25	P8CS1205AA
		Profibus DP	M12 - B coding	25	P8CS1205AB
	Bus OUT male connector	DeviceNet	M12 - A coding	25	P8CS1205BA
	Profibus DP	M12 - B coding	25	P8CS1205BB	
	Cable quick connect connector		M8	25	P8CS0803J
			M12 - A coding	25	P8CS1204J
		"Y" shape, thread to thread	M12 - 2 x M12	25	P8CSY1212A

16 Outputs Moduflex Bus ends module adaptor

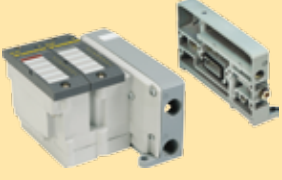

TURCK
Industrial Automation

P S M T 2 1 A P

TURCK BL67 Series adaptor		Ported design		Thread type
T0	Valve Driver Module without output module	1	Side ported	3/8" BSPP
T1	Valve Driver Module for 16 Outputs	2	Bottom ported	3/8" BSPP
T2	Valve Driver Module for 32 Outputs	5	Side ported	3/8" NPT
		6	Bottom ported	3/8" NPT

For T0 version, 16 output module and blank module can be ordered separately from the next page or directly from TURCK under the same part number.

Valve driver Module for 16 or 32 Outputs

Modularity up to 16 or 32 Outputs :

- Populated with 1 or 2 standard TURCK 16 Output modules BL67-16DO-0. 1A-P, the Valve Driver Module can handle up to 16 or 32 solenoid valves.
- For a 16 Outputs configuration, the second slot has to be populated with 1 standard TURCK blank module BL67-E.



TURCK BL67 communication gateway

Industrial Communication :

- Linked to a TURCK BL67 communication module (programmable or not programmable), the device can be connected to a wide choice of Field Bus or Industrial Ethernet protocols.

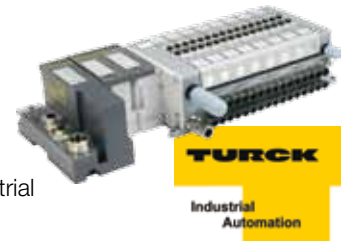

TURCK BL67 I/O and Base modules

The 2 piece design allows to complete the device with a choice through a full digital or analogue **I/O modules** range populating the **base module** existing with a multiple choice of electrical connection (M8, M12, M23, 7/8")

The complete resulting configuration can handle :

- Up to 32 electrical modules (up to 2 in the Valve Driver Module)
- Up to 256 digital I/O (up to 32 outputs in the Valve Driver Module)
- Up to 64 analog I/O

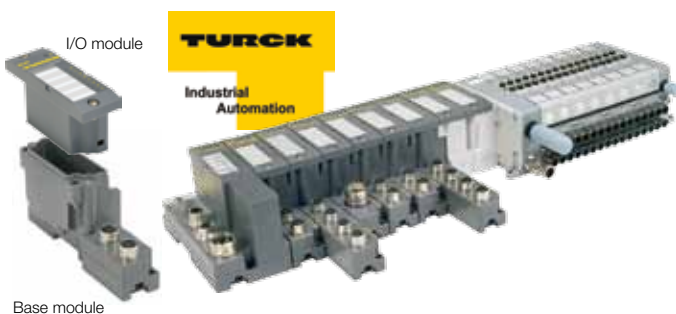

BL67 Ethernet IP gateway to DeviceNet

Using the TURCK BL67 Ethernet/IP gateway with DeviceNet master BL67-GW-EN-IP-DN, you can easily connect and configure a DeviceNet subnetwork thanks to the "Magic Black Button".



Full description of TURCK BL67 Series on <http://www.turck.com>

Valve Driver Module - TURCK BL67 adaptor

	Description	Solenoid Valves	Sub-base design	Thread type	Weight (g)	Order code	
	Valve Driver Module	0	Side ported	3/8" BSPP	200	PSMT01AP	
		Without 16 O module	Bottom ported	3/8" BSPP	200	PSMT02AP	
	16 Outputs or blank module to be ordered separately (see below)						
		16		Side ported	3/8" BSPP	270	PSMT11AP
		Including : - 1 x 16 O module - 1 blank module		Bottom ported	3/8" BSPP	270	PSMT12AP
		32		Side ported	3/8" BSPP	310	PSMT21AP
	Including : - 2 x 16 O modules		Bottom ported	3/8" BSPP	310	PSMT22AP	

Standard TURCK BL67 module

	Description	Weight (g)	Order code
	16 Outputs module for 16 or 32 solenoid valves configuration	55	BL67-16DO-0.1A-P
	Blank module for 16 solenoid valves configuration	15	BL67-E

Both standard TURCK BL67 Outputs module and Blank module can be ordered directly from TURCK under the same part number.

16 Outputs module BL67-16DO-0.1A-P technical specifications

Number of channels	16	Dimensions (W x L x H)	32 x 91 x 59 mm
Nominal voltage V_O	24 VDC	Approvals	CE, cULus
Rated current from field supply	≤ 100 mA	Operating temperature	Refer to solenoid valve
Rated current from module bus	≤ 30 mA	Storage temperature	-40°C to +70°C
Power loss, typical	≤ 1.5 W	Vibration	According to IEC68-2-6 : 2g to 150 Hz
		Shock test	According to IEC68-2-27 : 15g to 11 ms
Output type	PNP	Electro-magnetic compatibility	acc. to EN61131-2
Output voltage	24 VDC	Protection class	IP 65
Output current per channel	140 mA rated current (with VN 01-05 or higher)	Tightening torque fixing screws	0.9 ... 1.2 Nm
Output delay	3 ms		
Load type	resistive, inductive		
Short-circuit protection	yes		
Simultaneity factor	1		
Electrical isolation	electronics for the field level		

16 Outputs Moduflex Bus ends module adaptor



P S M M C 1 A P

Moduflex 16 Outputs adaptor	
M4	Adaptor without bus module
MC	Adaptor with CANopen module
MD	Adaptor with DeviceNet module
MP	Adaptor with Profibus DP module

Ported design		Thread type
1	Side ported	3/8" BSPP
2	Bottom ported	3/8" BSPP
5	Side ported	3/8" NPT
6	Bottom ported	3/8" NPT

For AS-i communication, use M4 and see Moduflex Valve catalogue for AS-i module part number.

Moduflex Bus 16 Outputs

16 solenoids fieldbus modules available in DeviceNet, CANopen, and Profibus DP protocols.



Closer to the cylinder

Decentralized application when solenoid valves have to be closer to the pneumatic actuators.

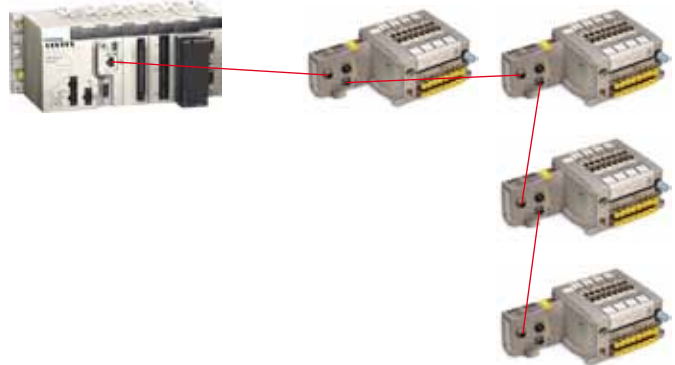

Technical data

Moduflex Bus communication modules

Bus power supply :	20 to 30 VDC
Power supply output voltage :	24 VDC
Module consumption :	
• DeviceNet :	1,5 W
• CANopen :	1,5 W
• Profibus DP :	1,5 W
Water and dust Protection :	IP65
Output protection :	overload protected

Moduflex Bus modules

Description	Bus protocol	Sub-base design	Thread type	Weight (g)	Order code
	CANopen	Side ported	3/8" BSPP	250	PSMMC1AP
		Bottom ported	3/8" BSPP	250	PSMMC2AP
	DeviceNet	Side ported	3/8" BSPP	250	PSMMD1AP
		Bottom ported	3/8" BSPP	250	PSMMD2AP
	Profibus DP	Side ported	3/8" BSPP	250	PSMMP1AP
		Bottom ported	3/8" BSPP	250	PSMMP2AP

Also available, AS-i interface protocol, standard version or extended version (A - B coded). See Moduflex Valve catalogue.

	All	Side ported	3/8" BSPP	200	PSMM41AP
		Bottom ported	3/8" BSPP	200	PSMM42AP

For configuration files, go to : <http://www.parker.com/pneu/moduflex>.

Decentralized Device bus accessories

Description	Bus protocol	Connector type	Weight (g)	Order code
	All	M12 - A coding	25	P8CS1205AA
	DeviceNet CANopen	M12 - A coding	25	P8BPA00MA
		Profibus DP	M12 - B coding	25
Bus IN female connector	DeviceNet CANopen	M12 - A coding	25	P8CS1205AA
		Profibus DP	M12 - B coding	25
	Bus OUT male connector	DeviceNet CANopen	M12 - A coding	25
Profibus DP			M12 - B coding	25
Cable quick connect connector		M8	25	P8CS0803J
		M12 - A coding	25	P8CS1204J
"Y" shape, thread to thread		M12 - 2 x M12 - A coding	25	P8CSY1212A

Multi-connection head module



P
S
M
L
2
1
A
P

Multi-wire connection		Ported design		Thread type	
L2	Sub-D25 connector	1	Side ported		3/8" BSPP
		2	Bottom ported		3/8" BSPP
		5	Side ported		3/8" NPT
		6	Bottom ported		3/8" NPT

Sub-D25 connection

Up to 24 solenoids on standard Sub-D25 connector.



Technical data

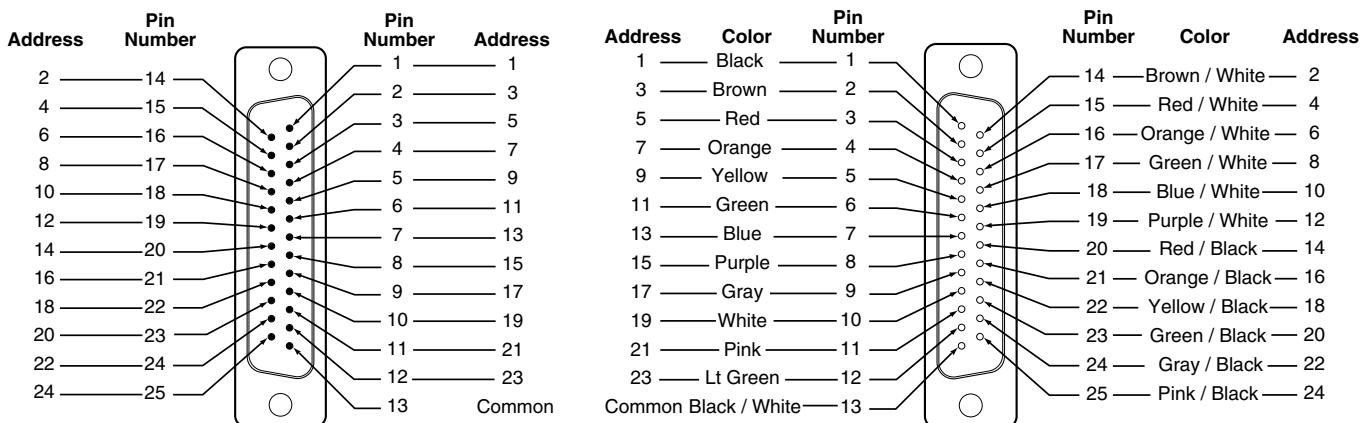

Rated voltage :	24 VDC
Maximum addresses :	24
Maximum energised simultaneously :	24
Electrical connection :	Sub-D25 pin DIN 41652, MIL-C-24308, NFC93425 type HE5
Polarity :	PNP and NPN compatible (solenoids not polarized)
Dust and water protection :	IP65 rated with properly assembled IP65 rated cable

Electrical multi-pole end modules

	Description	Sub-base design	Thread type	Weight (g)	Order code
	Sub-D25 ends module	Side ported	3/8" BSPP	250	PSML21AP
		Bottom ported	3/8" BSPP	250	PSML22AP

Electrical accessories

	Description	Cable length	Weight (g)	Order code
	Sub-D25 connector IP40 with flying leads multi-cable	3 m	380	P8LMH25M3A
		9 m	780	P8LMH25M9A
P8LMH25M3A	Sub-D25 connector IP65 with flying leads multi-cable	9 m	790	P8LMH25B9A

Centralized bus - Side ported

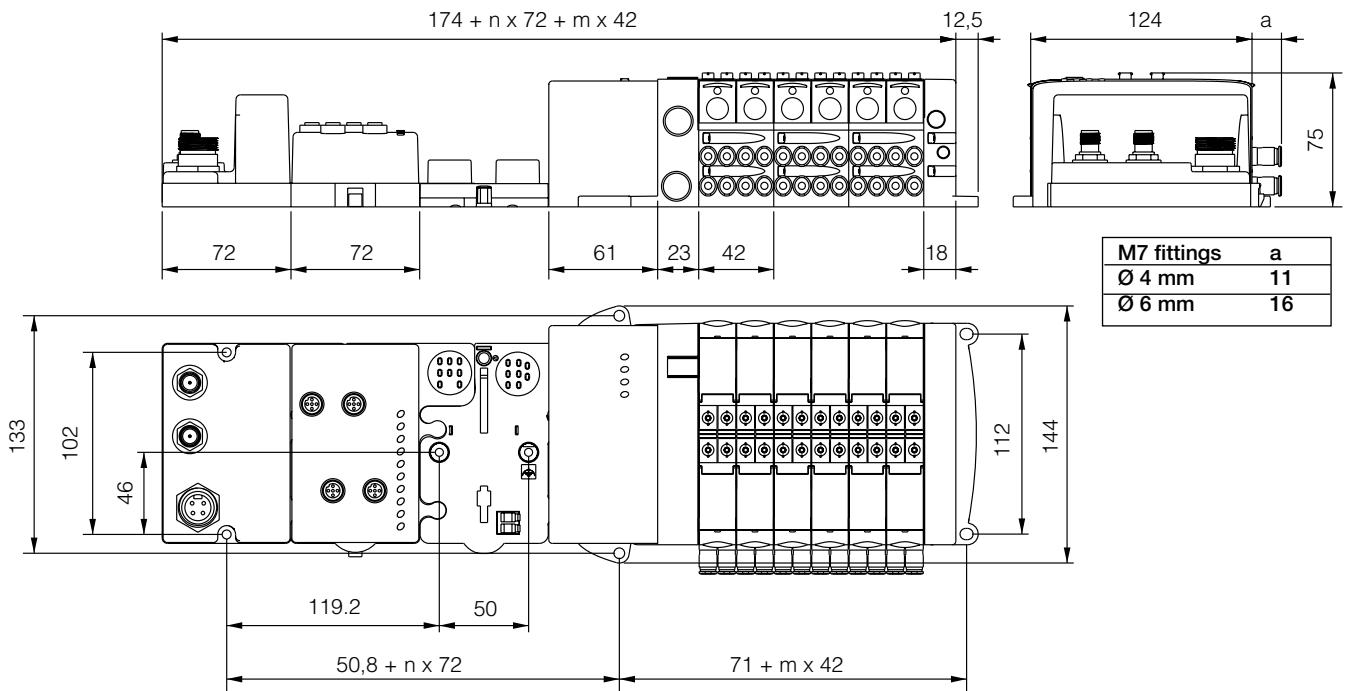

Centralized bus - Bottom ported

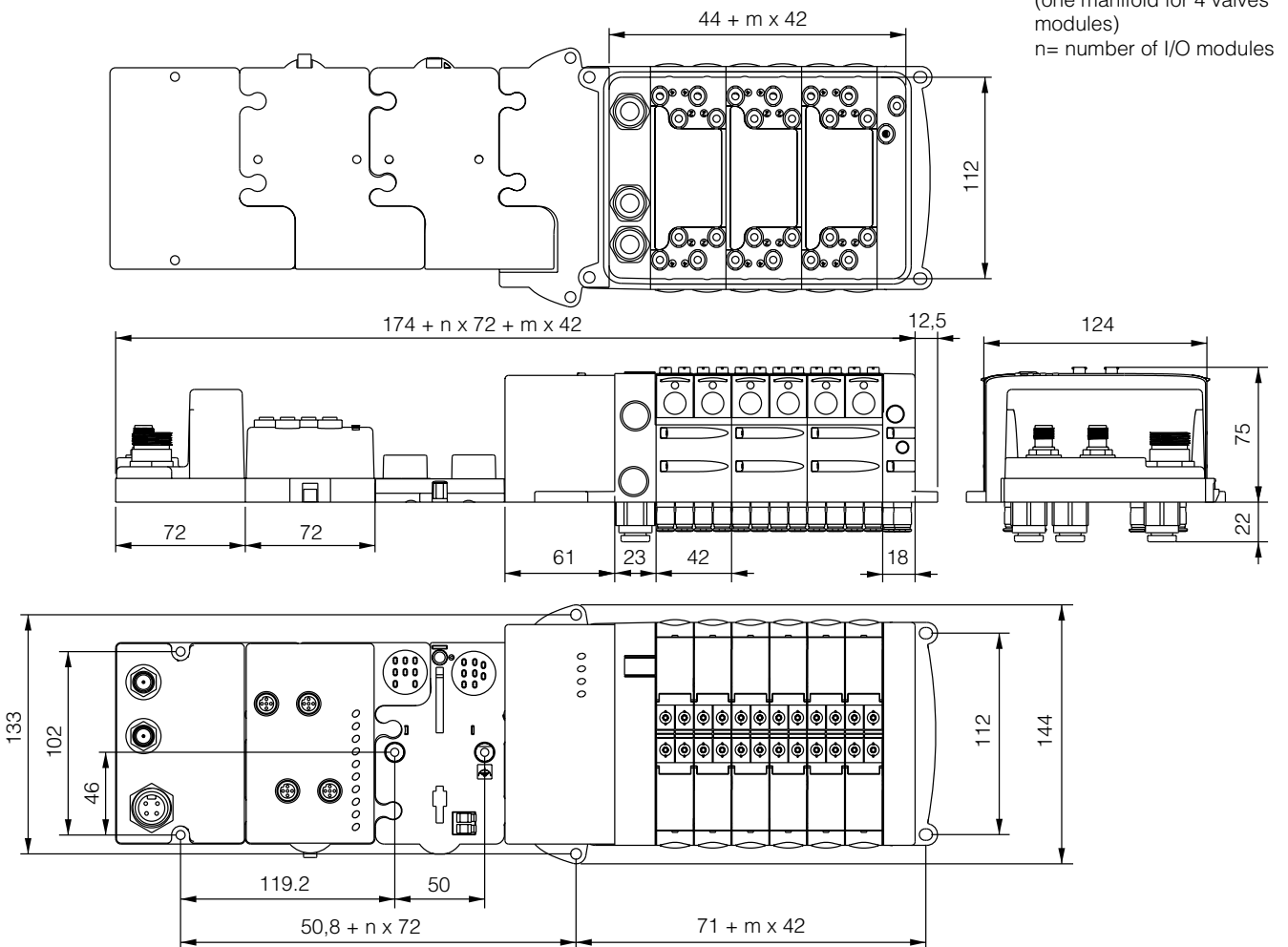

Isys Micro with TURCK BL67 adaptor - Side ported

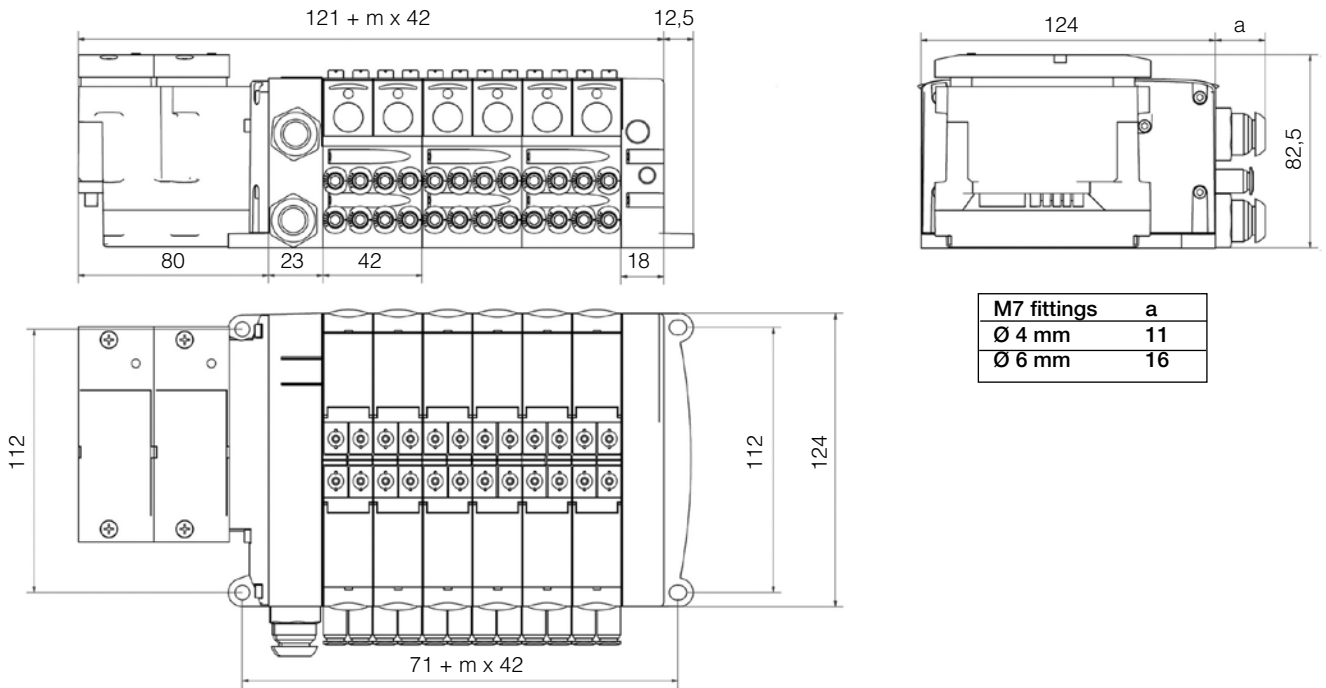

Isys Micro with TURCK BL67 adaptor - Bottom ported

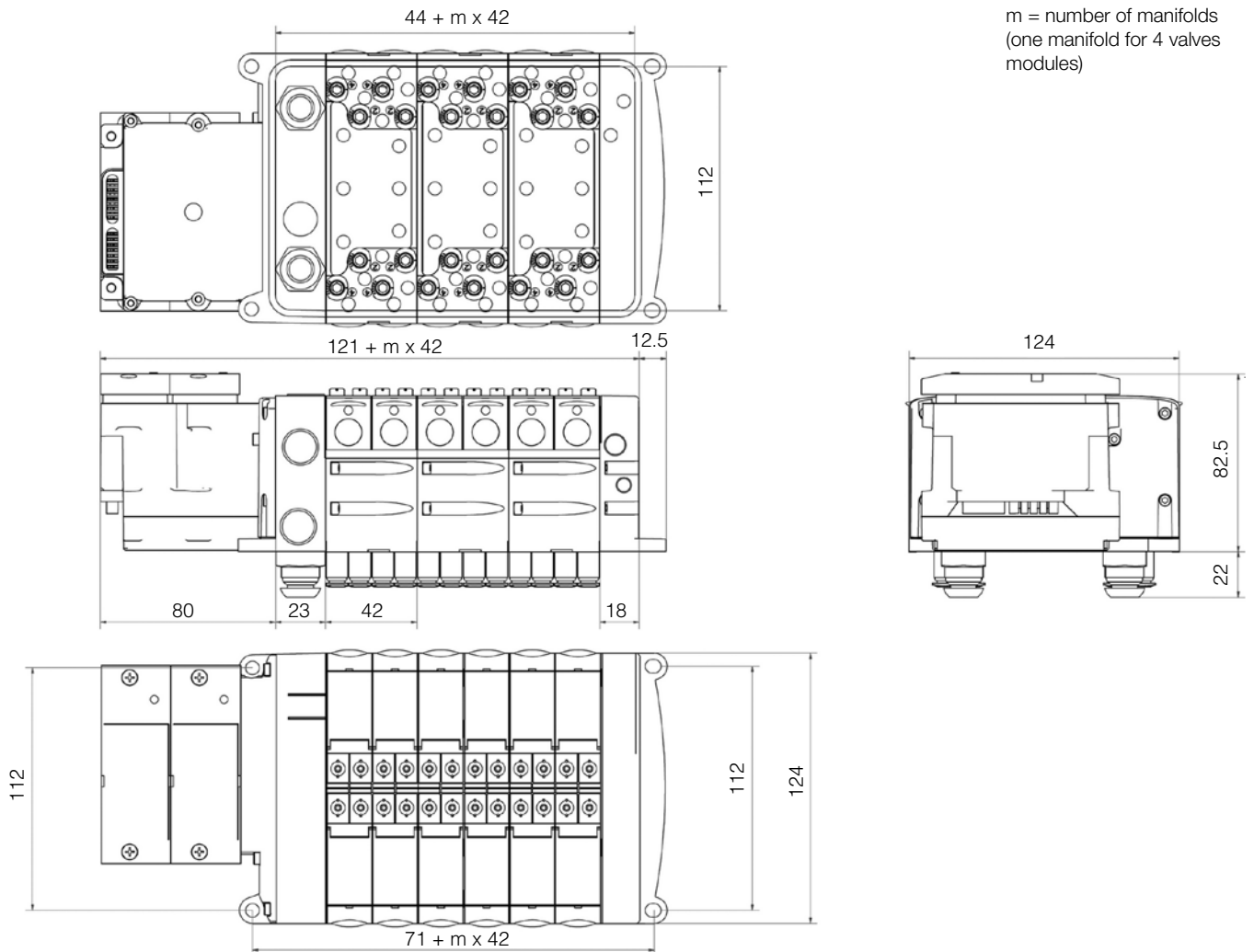

Note:
 m = number of manifolds
 (one manifold for 4 valves
 modules)

Fieldbus - Side ported

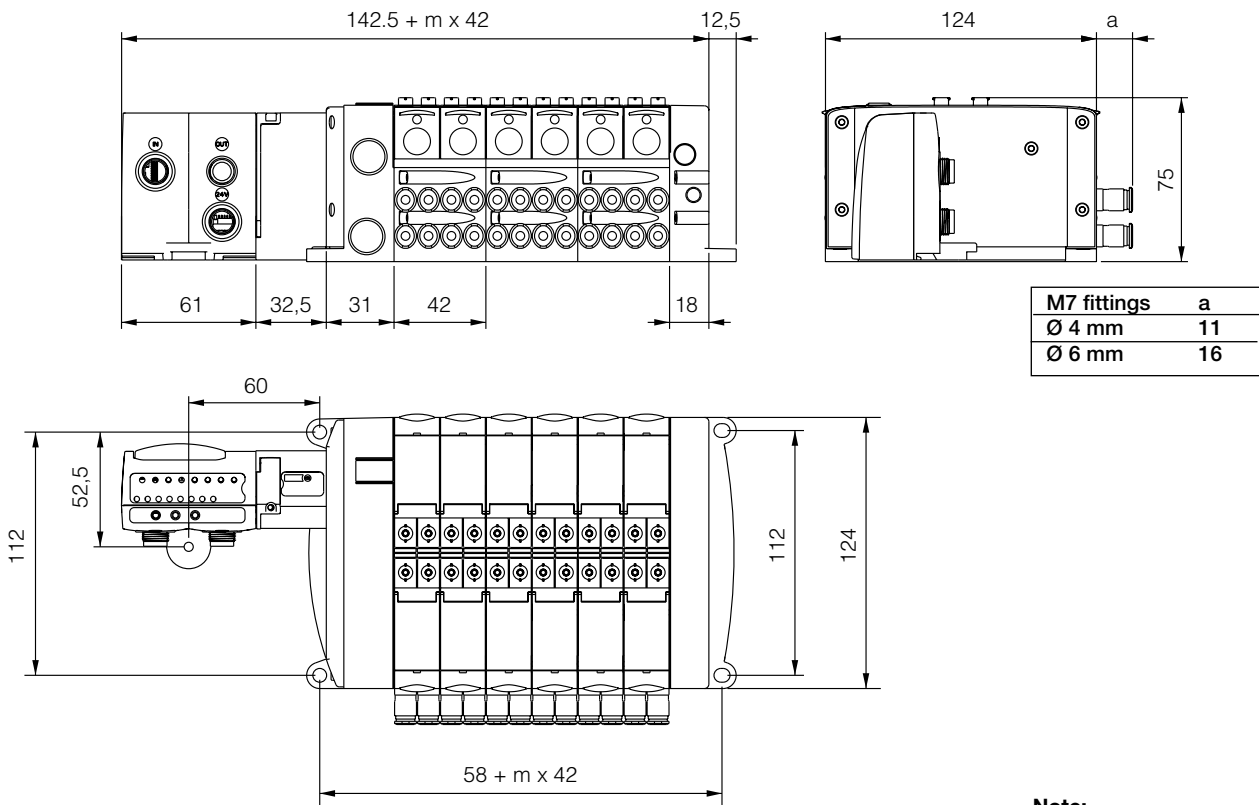

Note:

m = number of manifolds
(one manifold for 4 valves modules)

Fieldbus - Bottom ported

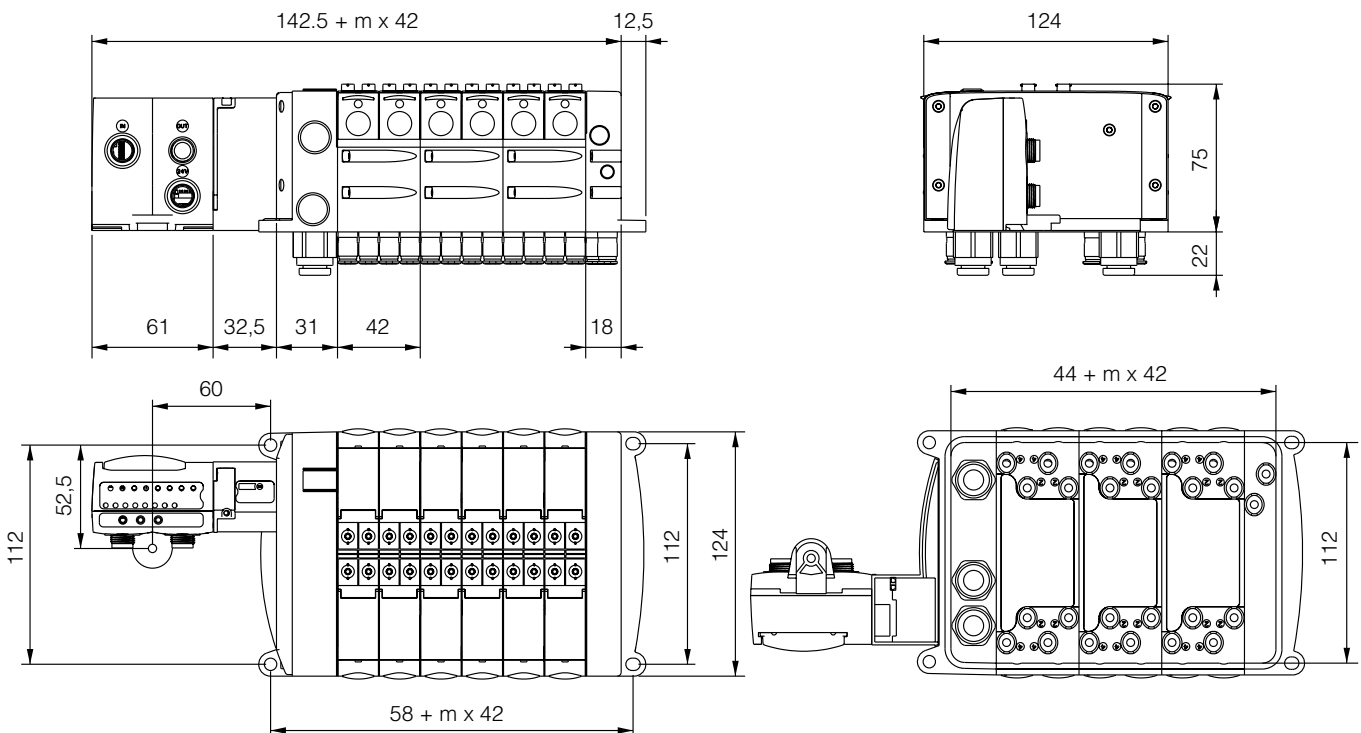

SubD25 - Side ported

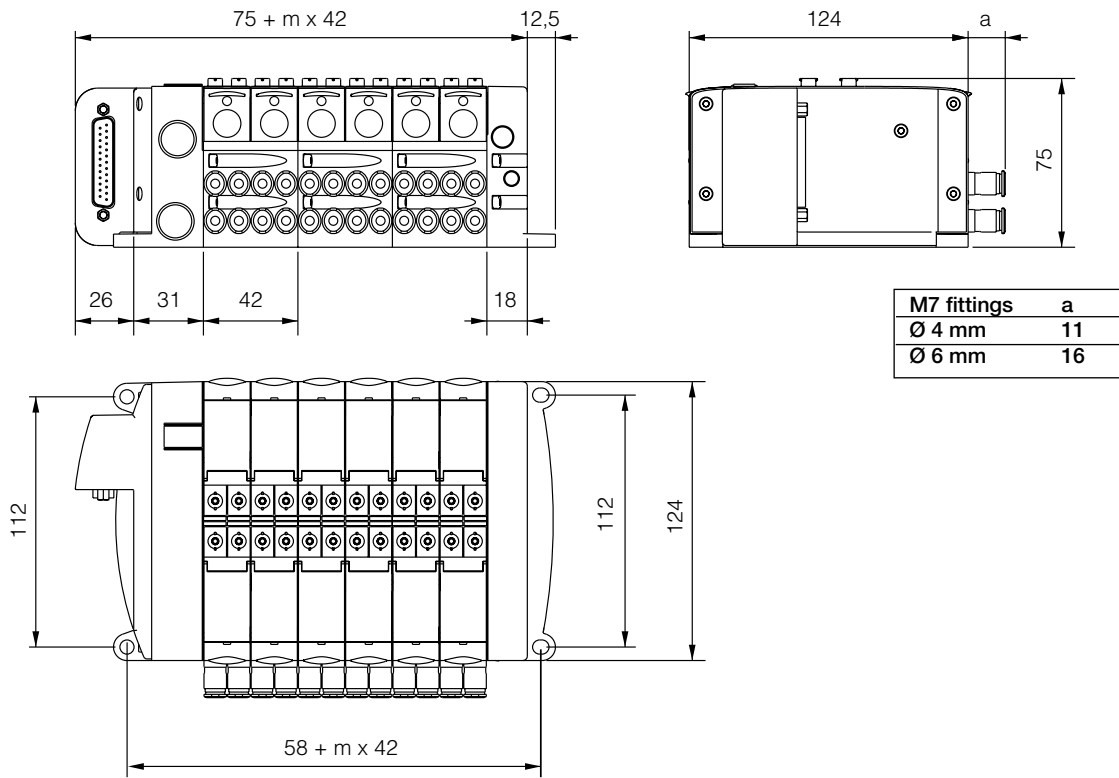

Note:
 m = number of manifolds
 (one manifold for 4 valves
 modules)

SubD25 - Bottom ported

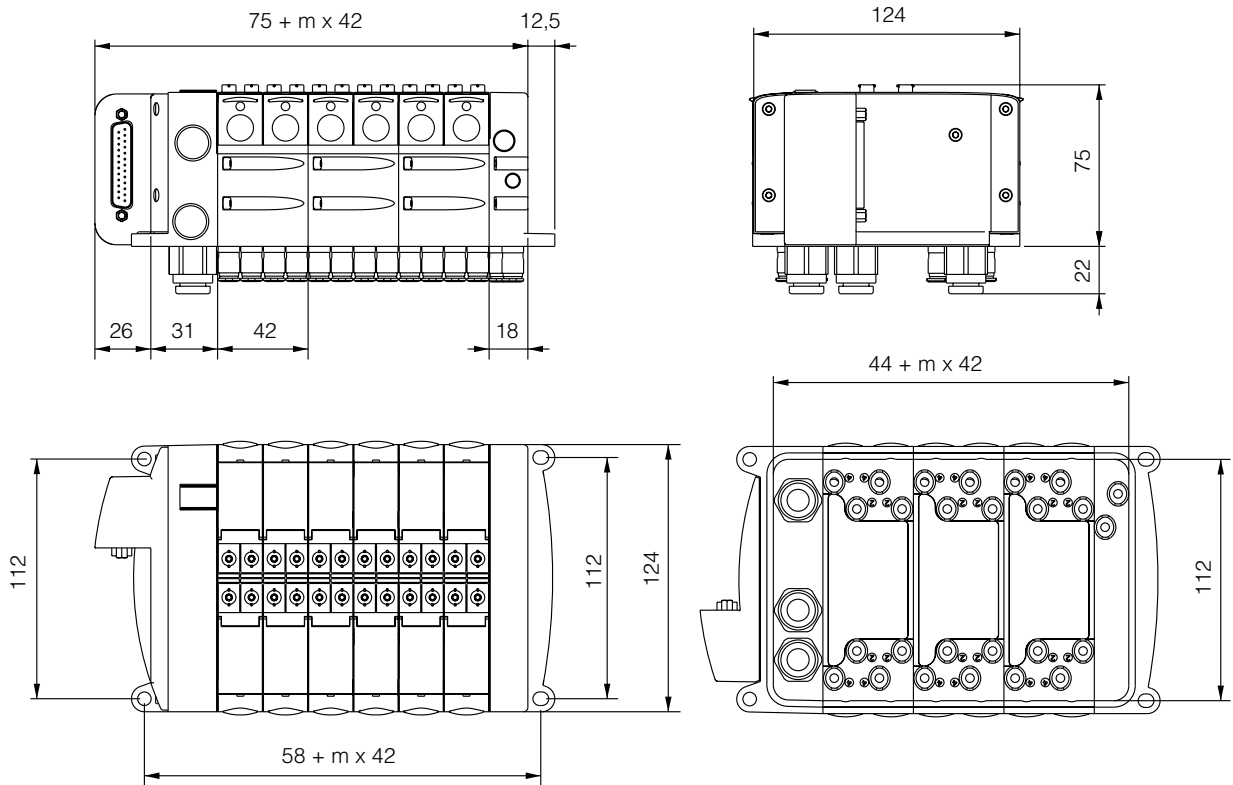

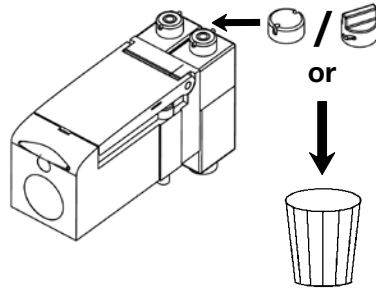

0,4 mN mini.
0,6 mN maxi.

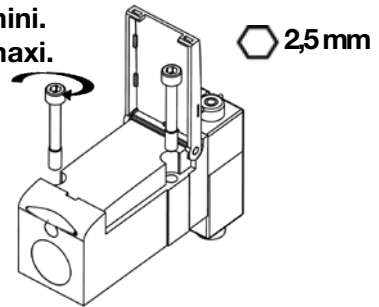

A

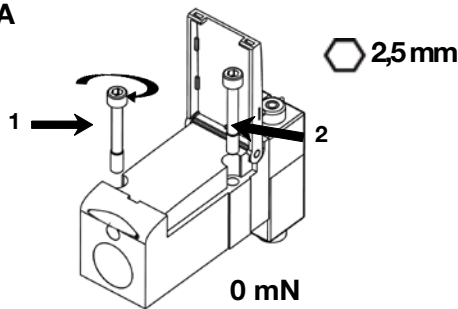

B

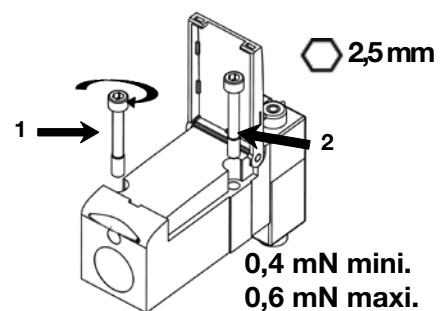

W930019620111

<http://www.parker.com/Pneumatic>

300196201W05 02



**Isys Micro
Installation & Service Instructions
Sheet B**

**ISSUED: 06 2008
Supersedes: None**

WARNING: Failure to follow all precautions, warnings, instructions, and information contained herein, and from the Parker website, may cause death, personal injury, and/or property damage. More detailed information, in several languages, may be obtained from the Parker website:

www.parker.com or call 1-800-C PARKER in the USA or 00 800 27 27 53 74 in Europe.

W930019620111

<http://www.parker.com/Pneumatic>

300196201W05 02

GENERAL SAFETY GUIDELINES

- Always disconnect the electric and air supply to the valve before adjusting.
- Always lockout power to machinery that the valve is attached to before adjusting.
- Keep hands and clothing away from any pinch points & paths of moving cylinders.
- Never disassemble valves without proper instruction and manuals. This may be obtained from a distributor or the website described above.

GENERAL INSTALLATION GUIDELINES

- Push plug-in pneumatic connectors securely into the modules and assemble the valve islands as shown on reverse side.
- Secure the valve or valve island using the din-rail fasteners or the mounting holes.
- Attach Parker tubing to the pneumatic connectors. Completely push clean, square-cut precision tubing into the pneumatic connectors.
- Attach electrical connections with power off.
- Test the system operation for function and leakage. Do not put into operation until the function is as intended and there is no leakage.



PSM . . AP

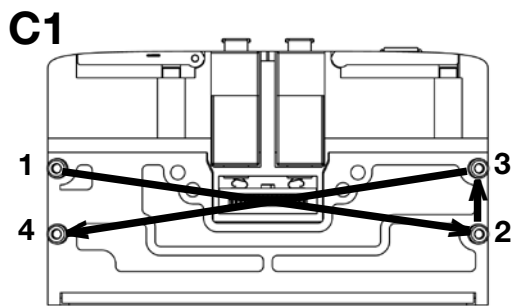
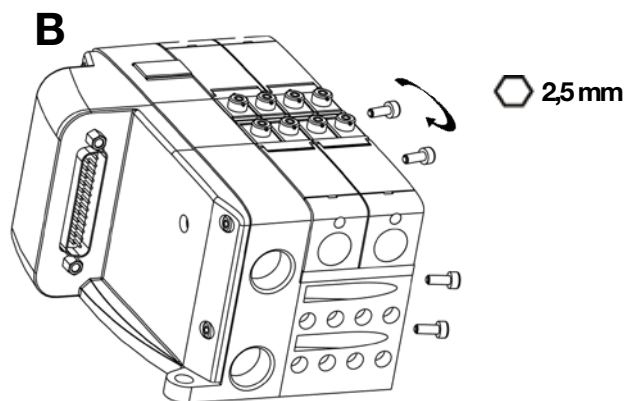
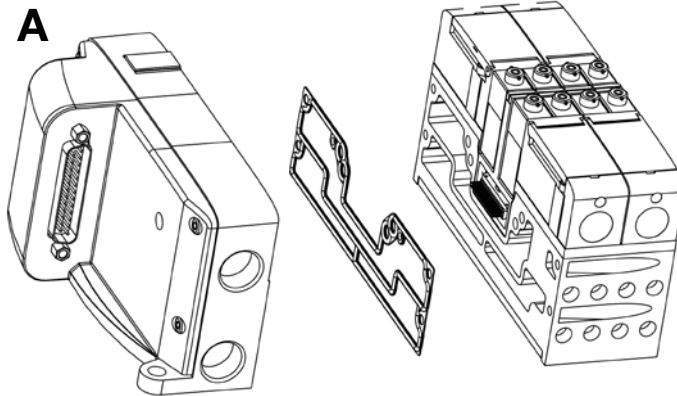

1, 2, 3, → 4 ↻ 0 mN

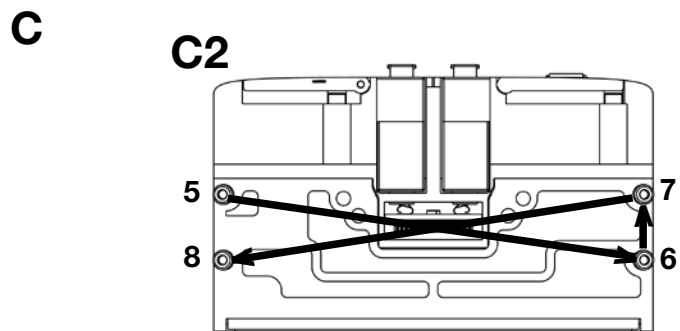

5, 6, 7, → 8 ↻ 0,5 mN mini.
0,8 mN maxi.

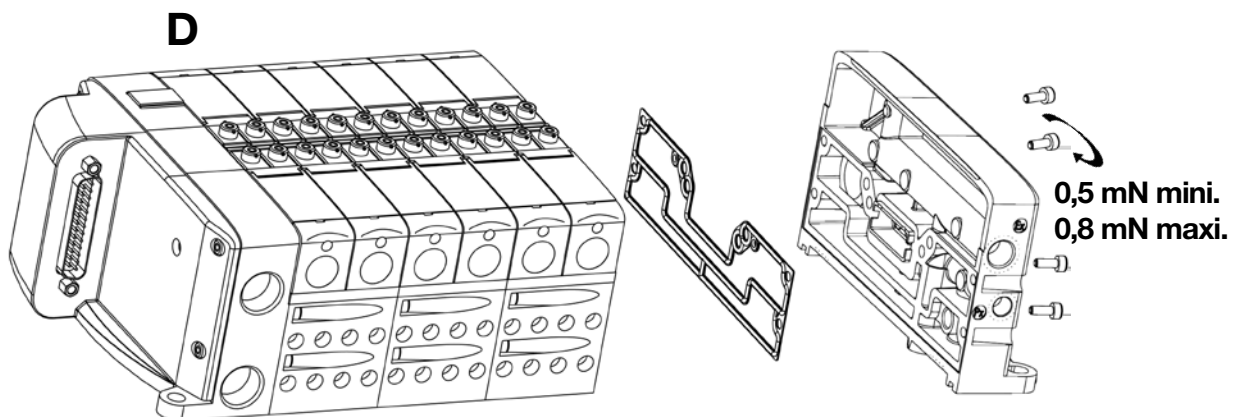

W930019630111

<http://www.parker.com/Pneumatic>

300196301W05 02





Inter-manifold seal plate

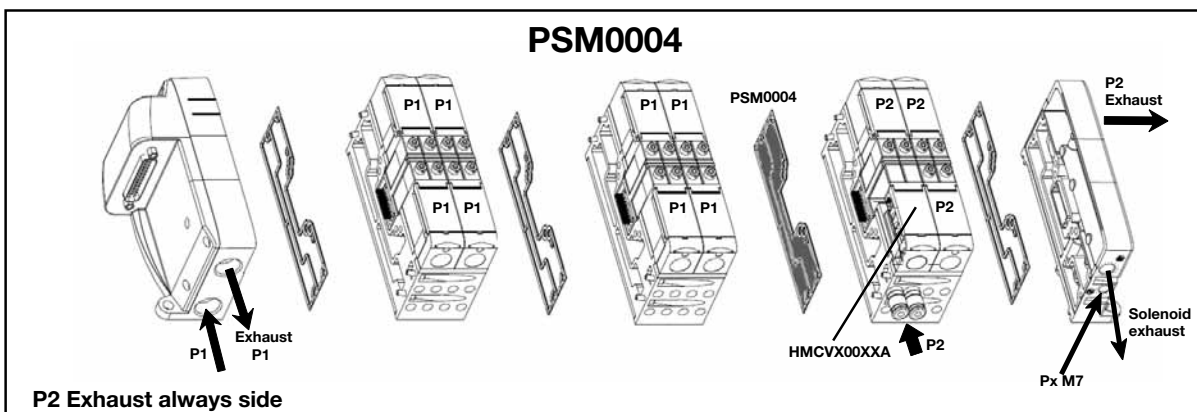
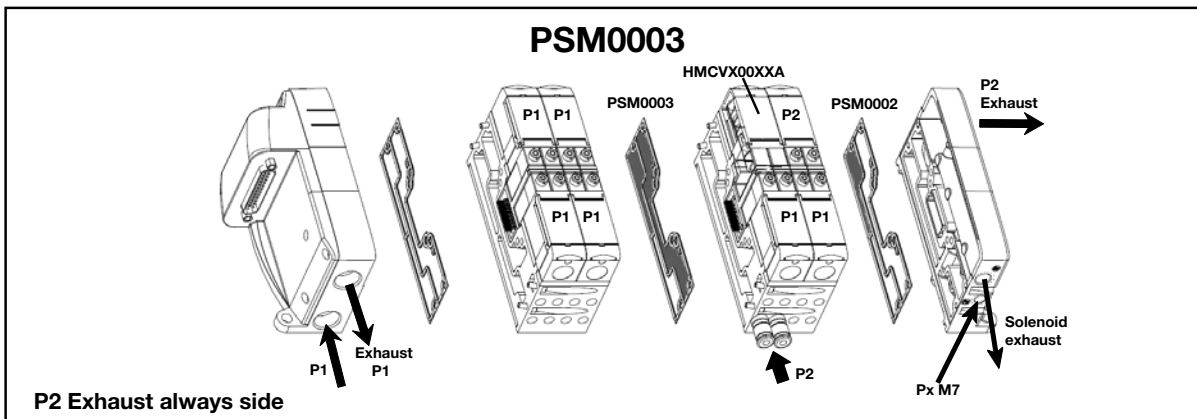
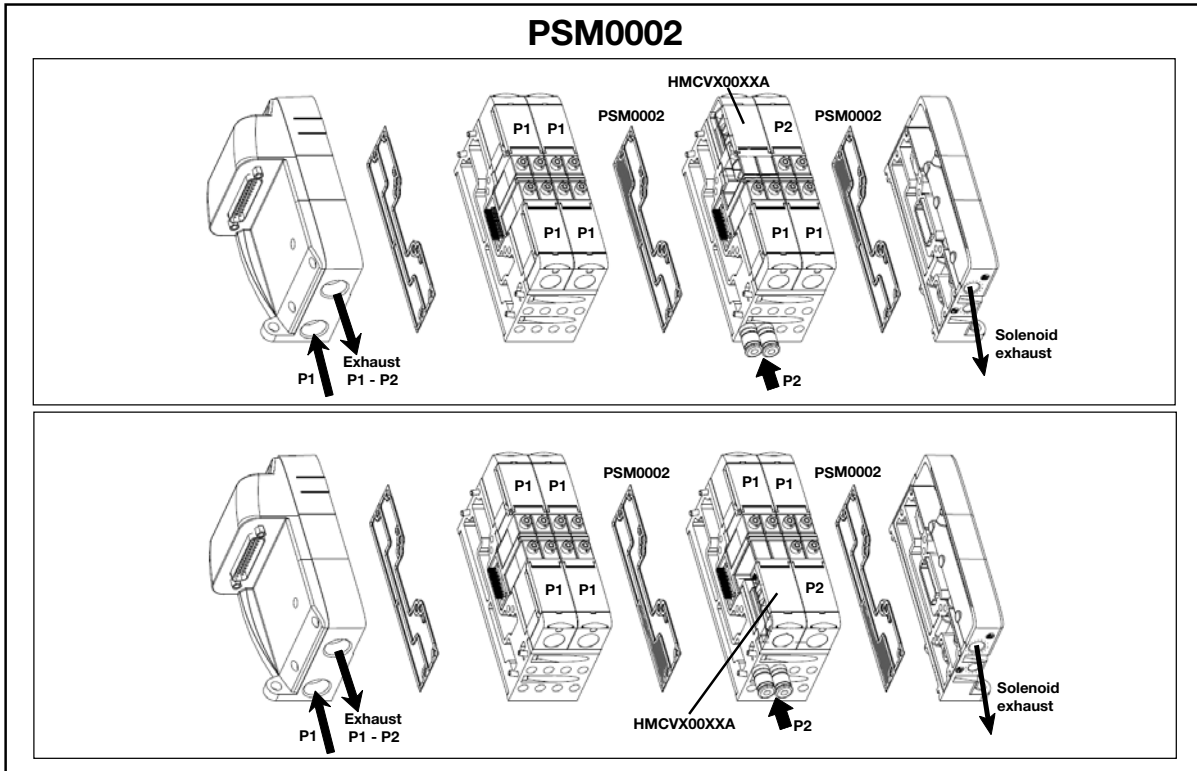

Operating pressure -0.9 to 8.3 bar, with external pilot pressure 6 bar. Solenoid pressure supply 2.7 to 8.3 bar



PSM...AP

Side ported

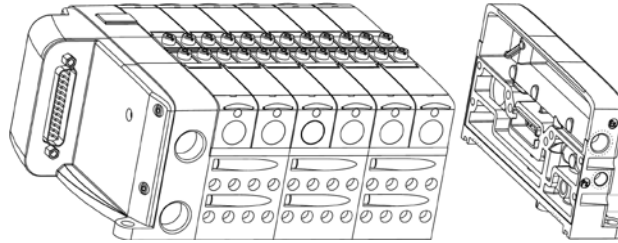

Internal solenoids pilot supply

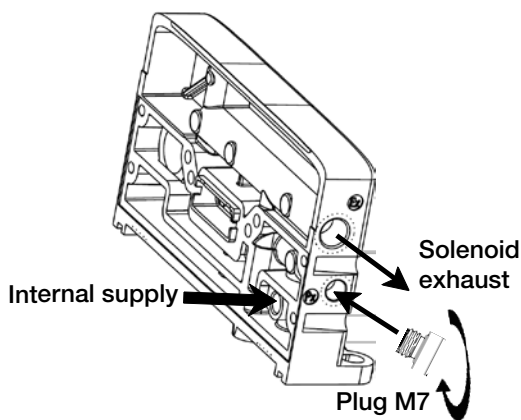

External solenoids pilot supply

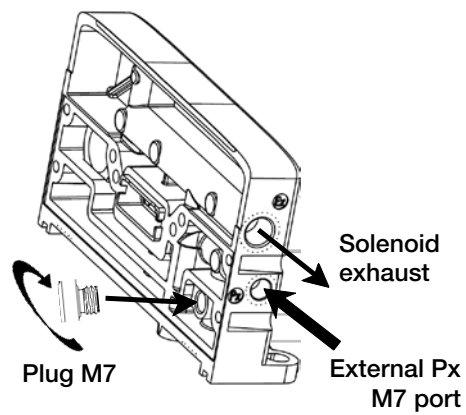

Bottom ported

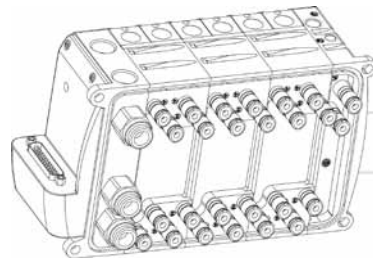

Internal solenoids pilot supply

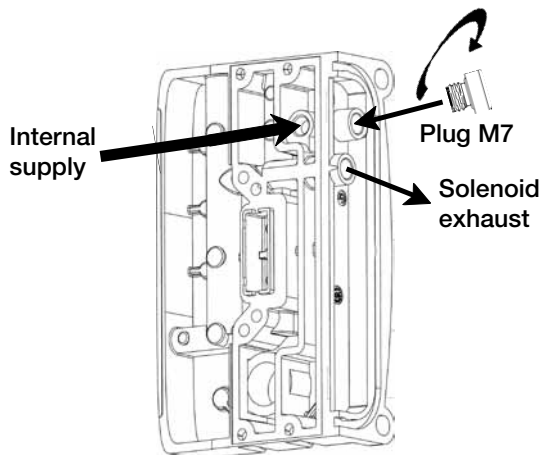

External solenoids pilot supply

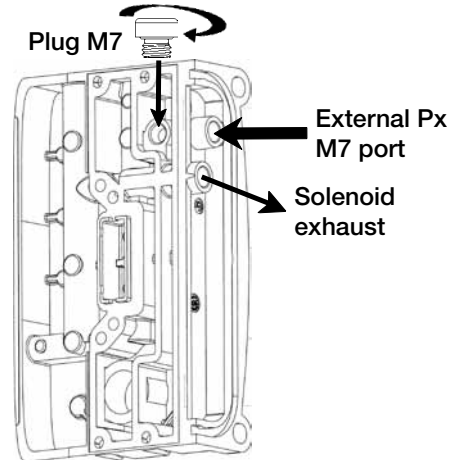

Operating pressure -0.9 to 8.3 bar, with external pilot pressure 6 bar. Solenoid pressure supply 2.7 to 8.3 bar





ISYS-Micro Installation & Service Instructions Sheet B

Supersedes: None

⚠️ Avertissement Danger : Le non-respect des précautions, mises en garde, instructions et informations décrites dans le présent document ou sur le site Parker peut provoquer des dommages matériels et des blessures graves même mortelles. Des précisions complémentaires en plusieurs langues peuvent être obtenues en visitant le site web Parker: www.parker.com ou appeler le 00 800 27 27 53 74 en Europe.

CONSIGNES GENERALES DE SECURITE

- Débrancher toujours les alimentations électrique et pneumatique du distributeur avant réglage.
- Couper toujours l'énergie de l'équipement avant réglage.
- Garder les mains et les vêtements hors de portée des points de pincement des pièces en mouvement.
- Ne jamais démonter les distributeurs sans les instructions ou manuels appropriés. Ces derniers peuvent être obtenus chez nos distributeurs ou sur le site web.

CONSIGNES GENERALES D'INSTALLATION

- S'assurer du bon positionnement des connecteurs pneumatiques dans leur logement.
- Fixer l'îlot sur un bâti à l'aide des logements.
- Utiliser des tubes Parker. Ils doivent être propres, coupés droits, sans résidu, et enfoncés complètement.
- Connecter électriquement les distributeurs ou îlots hors tension.
- Tester les fonctions et fuites du système. Ne jamais mettre en service sans s'assurer préalablement du bon fonctionnement et de l'absence de fuites.

⚠️ ACHTUNG : Nichtbeachten der hier und auf der Parker Website aufgezeigten Vorsichtsmassregeln, Hinweise, Anleitungen und Informationen kann zu Tod, Personenschäden und/oder Zerstörung der Einrichtungen führen. Genauere Informationen -in verschiedenen Sprachen- können von der Parker Website : www.parker.com abgerufen werden. T : 00 800 27 27 53 74.

Allgemeine Sicherheitsrichtlinien

- Vor jeglicher Einstellarbeit an den Ventilen bzw. der Ventilseln sind die Druckluftleitungen zu trennen.
- Vor jeglicher Einstellarbeit an den Ventilen bzw. der Ventilseln ist der entsprechende Anlagenteil energie- und spannungslos zu machen.
- Halten Sie Abstand mit Händen und Kleidung von Klemmstellen (z.B. von Zylindern).
- Bauen Sie niemals Komponenten auseinander ohne entsprechend geeignete Anleitungen. Sie können diese erhalten von unseren Fachhändlern, eigenen Niederlassungen oder von der Webseite abrufen.

Allgemeine Installationsrichtlinien

- Drücken Sie die Einsteck-Schnellverbinder fest und sicher in die Basismodule wie gezeigt.
- Sichern Sie die Ventilseln durch Befestigungsschrauben an auf einer Montagefläche.
- Benutzen Sie nur Parker Kunststoffrohr in Verbindung mit den Schnellsteckverbindern. Das Rohr muss sauber, rechteckig abgeschnitten, ohne lose Partikel und komplett in die Verbinder gesteckt sein.
- Stellen Sie die elektrische Verbindung in spannungslosem Zustand her.
- Testen Sie das System auf Funktion und Leckagen. Nehmen Sie das System erst in Betrieb wenn die Funktionen wie geplant ablaufen und keine Leckagen vorhanden sind.

⚠️ WARNING: Failure to follow all precautions, warnings, instructions, and information contained herein, and from the Parker website, may cause death, personal injury, and/or property damage. More detailed information, in several languages, may be obtained from the Parker website: www.parker.com or call 1-800-C PARKER in the USA or 00 800 27 27 53 74 in Europe.

GENERAL SAFETY GUIDELINES

- Always disconnect the electric and air supply to the valve before adjusting.
- Always lockout power to machinery that the valve is attached to before adjusting.
- Keep hands and clothing away from any pinch points & paths of moving cylinders.
- Never disassemble valves without proper instruction and manuals. This may be obtained from a distributor or the website described above.

GENERAL INSTALLATION GUIDELINES

- Push plug-in pneumatic connectors securely into the modules and assemble the valve islands as shown on reverse side.
- Secure the valve or valve island using the din-rail fasteners or the mounting holes.
- Attach Parker tubing to the pneumatic connectors. Completely push clean, square-cut precision tubing into the pneumatic connectors.
- Attach electrical connections with power off.
- Test the system operation for function and leakage. Do not put into operation until the function is as intended and there is no leakage.

⚠️ ADVERTÊNCIA: O não cumprimento de todas as advertências, instruções e informações contidas nesta, pode causar morte, danos pessoais e/ou danos materiais. Maiores detalhes, em outras línguas, podem ser obtidos do website Parker : www.parker.com T : 00 800 27 27 53 74 (Europe).

INSTRUÇÕES GERAIS PARA SEGURANÇA

- Sempre desconecte a eletricidade e suprimento de ar da válvula antes da regulagem ou instalação das unidades.
- Sempre desconecte a válvula de qualquer máquina/equipamento antes da regulagem ou instalação.
- Mantenha as mãos e vestuário longe de pontos onde há riscos de agaramentos ou movimentos de cilindros para evitar acidentes.
- Nunca desmonte as válvulas sem manuais e instruções apropriados. Estes podem ser obtidos da fábrica ou do website descrito anteriormente.

INSTRUÇÕES GERAIS PARA INSTALAÇÃO

- Pressione os conectores especiais dentro das unidades de válvulas como mostrado
- Instale o conjunto do manifold na superfície utilizando parafusos nos furos de montagem.
- Conecte somente tubos Parker. Estes devem estar limpos, com corte das extremidade no esquadro, sem partículas soltas, e pressionadas completamente dentro das conexões.
- Faça as conexões elétricas com a linha desenergizada.
- Teste o sistema para checar o funcionamento e vazamentos. Não coloque o sistema em operação antes de checar se o funcionamento está adequado e não há vazamentos.

⚠️ WAARSCHUWING: Verzamen tot het volgen van alle voorzorgsmaatregelen, en informatie zoals hier samengevat en op de Parker website, kan persoonlijk letsel, eigendomschade, of zelfs de dood tot gevolg hebben. Meer detail informatie, zie www.parker.com T : 00 800 27 27 53 74 (Europe).

Algemene veiligheidsrichtlijnen

- Altijd de lucht- en stroomtoevoer naar het ventiel afsluiten voor men gaat afstellen.
- Altijd de energie naar de machine waar het ventiel op gemonteerd zit afsluiten voor men gaat afstellen.
- Handen en kleding weghouden van de klem punten en bewegende cilindres.
- Nooit ventielen demonteren zonder de juiste instructie en handleidingen.

Algemene installatie voorschrift

- Bevestig speciale koppelingen precies zoals hierboven wordt getoond.
- Bevestig de ventielunit op ondergrond door schroeven te plaatsen.
- Alleen Parker leidingen in de koppelingen bevestigen. Deze moeten schoon en recht afgesneden zijn, zodat ze goed in de koppeling passen.
- Elektrische aansluitingen plaatsen, alleen als de voeding uit staat.
- Systeem testen op werking en lekkage. en niet in gebruik nemen voordat aan beide eisen voldaan is.

⚠️ PRECAUCION: La Negligencia a los avisos de precaución, instrucciones e información contenida aquí y en el sitio Web de Parker pueden causar la muerte, daños personales y/o daño a la propiedad. Mas información detallada en diferentes idiomas pueden ser obtenidos del sitio Web de Parker: www.parker.com o llamando al teléfono 1-800-C PARKER en los Estados Unidos de América o 00 800 27 27 53 74 en Europa.

NORMAS GENERALES DE SEGURIDAD

- Siempre desconecte el suministro de energía eléctrica y aire comprimido a la válvula antes de ajustar o instalar unidades.
- Siempre baje el interruptor de energía eléctrica de la maquinaria en la que la válvula esta instalada antes de ajustarla.
- Mantenga las manos y ropa fuera de cualquier punto apriete o partes móviles de los cilindros.
- Nunca desensamble válvulas sin los manuales o instrucciones adecuados. Estos pueden ser obtenidos de un distribuidor o del sitio Web descrito arriba.

NORMAS GENERALES DE INTALACION

- Presione los conectores especiales asegúrelos contra las bases como se muestra.
- Asegure el ensamble de manifold a la superficie usando conectores rápidos.
- Conecte solamente tubing Parker a las conexiones. Estos deberán de estar limpios, cortados en escuadra, sin partículas sueltas, y presionados completamente dentro de las conexiones.
- Realice las conexiones eléctricas con el interruptor de energía en apagado (OFF).
- Pruebe la operación del sistema verificando funcionamiento y fugas. No lo ponga en operación hasta que cumpla con la operación requerida y que no haya fugas.

⚠️ VARNING: Instruktioner, varningar och information i denna handling, och på Parkers websida, skall åtdydas noggrant. Följden av att bortsä från dessa kan medföra dödsfall, personskador och/eller skador på egendom. Detaljerad information, på flera språk kan hämtas från Parkers websida www.parker.com eller ring 00 800 27 27 53 74 (Europe).

GENERELLA SÄKERHETSANVISNINGAR

- Stäng alltid av både el och luftförsörjningen innan justeringar på ventilen genomförs.
- Bryt alltid huvudströmmen till maskinen som ventilen betjänar.
- Se till att hålla undan händer och kläder från klämrisiker.
- Plocka aldrig isär en ventil utan att ha först hämtat underlag för detta från websidan eller leverantören..

GENERELLA INSTALLATIONSANVISNINGAR

- Tryck de speciella anslutningarna ordentligt fast i underdelen, se bilden.
- Sätt fast ventillbas ordentligt på ett stabilt underlag.
- Montera enbart Parker slang i instickskopplingarna. Dessa måste skäras av rakt och vara utan s.k.skågg eller lösa partiklar samt tryckas helt in i kopplingen.
- Koppla in elen med huvudbrytaren i frånläge.
- Test systemet sedan för funktion och läckage. Starta ej maskin förrän fullgod funktion och täthet uppnåtts.

⚠️ ATTENZIONE! Il mancato rispetto delle precauzioni, avvertenze, istruzioni, ed informazioni contenute di seguito e nel sito web Parker, può provocare danni a cose o persone, anche con conseguenze letali. Per informazioni più dettagliate nelle varie lingue, consultare sito web Parker: www.parker.com o, negli Stati Uniti, chiamare il 00 800 27 27 53 74 (Europe).

ISTRUZIONI DI SICUREZZA

- Scollegare sempre la valvola dall'alimentazione elettrica e pneumatica prima di regolare le periferiche.
- Interrompere sempre l'alimentazione elettrica ai macchinari cui la valvola è collegata prima di procedere alla regolazione.
- Tenere le mani e gli abiti lontano dai cilindri in movimento in modo che non rimangano impigliati o intrappolate.
- Non smontare mai le valvole senza aver prima seguito scrupolosamente i manuali di istruzioni che si possono richiedere al distributore, o scaricare dal sito web sopra citato.

ISTRUZIONI GENERALI D'INSTALLAZIONE

- Inserire e fissare i raccordi speciali nelle basi come indicato nel disegno.
- Fissare il manifold ad un piano mediante i dispositivi di fissaggio indicati.
- Collegare ai raccordi esclusivamente tubi Parker. I tubi devono essere puliti con le estremità tagliate a squadra, senza parti libere e inseriti nel raccordo fino in fondo.
- Attaccare le connessioni elettriche ad apparecchio spento.
- Collaudare il sistema per controllarne il funzionamento ed individuare eventuali perdite. Non utilizzare finché il funzionamento non risulta corretto e senza perdite.

Parker Worldwide

Europe, Middle East, Africa

AE – United Arab Emirates, Dubai

Tel: +971 4 8127100
parker.me@parker.com

AT – Austria, Wiener Neustadt

Tel: +43 (0)2622 23501-0
parker.austria@parker.com

AT – Eastern Europe, Wiener Neustadt

Tel: +43 (0)2622 23501 900
parker.easteurope@parker.com

AZ – Azerbaijan, Baku

Tel: +994 50 2233 458
parker.azerbaijan@parker.com

BE/LU – Belgium, Nivelles

Tel: +32 (0)67 280 900
parker.belgium@parker.com

BY – Belarus, Minsk

Tel: +375 17 209 9399
parker.belarus@parker.com

CH – Switzerland, Etoy

Tel: +41 (0)21 821 87 00
parker.switzerland@parker.com

CZ – Czech Republic, Klecany

Tel: +420 284 083 111
parker.czechrepublic@parker.com

DE – Germany, Kaarst

Tel: +49 (0)2131 4016 0
parker.germany@parker.com

DK – Denmark, Ballerup

Tel: +45 43 56 04 00
parker.denmark@parker.com

ES – Spain, Madrid

Tel: +34 902 330 001
parker.spain@parker.com

FI – Finland, Vantaa

Tel: +358 (0)20 753 2500
parker.finland@parker.com

FR – France, Contamine s/Arve

Tel: +33 (0)4 50 25 80 25
parker.france@parker.com

GR – Greece, Athens

Tel: +30 210 933 6450
parker.greece@parker.com

HU – Hungary, Budapest

Tel: +36 1 220 4155
parker.hungary@parker.com

IE – Ireland, Dublin

Tel: +353 (0)1 466 6370
parker.ireland@parker.com

IT – Italy, Corsico (MI)

Tel: +39 02 45 19 21
parker.italy@parker.com

KZ – Kazakhstan, Almaty

Tel: +7 7272 505 800
parker.easteurope@parker.com

NL – The Netherlands, Oldenzaal

Tel: +31 (0)541 585 000
parker.nl@parker.com

NO – Norway, Asker

Tel: +47 66 75 34 00
parker.norway@parker.com

PL – Poland, Warsaw

Tel: +48 (0)22 573 24 00
parker.poland@parker.com

PT – Portugal, Leca da Palmeira

Tel: +351 22 999 7360
parker.portugal@parker.com

RO – Romania, Bucharest

Tel: +40 21 252 1382
parker.romania@parker.com

RU – Russia, Moscow

Tel: +7 495 645-2156
parker.russia@parker.com

SE – Sweden, Spånga

Tel: +46 (0)8 59 79 50 00
parker.sweden@parker.com

SK – Slovakia, Banská Bystrica

Tel: +421 484 162 252
parker.slovakia@parker.com

SL – Slovenia, Novo Mesto

Tel: +386 7 337 6650
parker.slovenia@parker.com

TR – Turkey, Istanbul

Tel: +90 216 4997081
parker.turkey@parker.com

UA – Ukraine, Kiev

Tel: +380 44 494 2731
parker.ukraine@parker.com

UK – United Kingdom, Warwick

Tel: +44 (0)1926 317 878
parker.uk@parker.com

ZA – South Africa, Kempton Park

Tel: +27 (0)11 961 0700
parker.southafrica@parker.com

North America

CA – Canada, Milton, Ontario

Tel: +1 905 693 3000

US – USA, Cleveland

Tel: +1 216 896 3000

Asia Pacific

AU – Australia, Castle Hill

Tel: +61 (0)2-9634 7777

CN – China, Shanghai

Tel: +86 21 2899 5000

HK – Hong Kong

Tel: +852 2428 8008

IN – India, Mumbai

Tel: +91 22 6513 7081-85

JP – Japan, Tokyo

Tel: +81 (0)3 6408 3901

KR – South Korea, Seoul

Tel: +82 2 559 0400

MY – Malaysia, Shah Alam

Tel: +60 3 7849 0800

NZ – New Zealand, Mt Wellington

Tel: +64 9 574 1744

SG – Singapore

Tel: +65 6887 6300

TH – Thailand, Bangkok

Tel: +662 186 7000 99

TW – Taiwan, Taipei

Tel: +886 2 2298 8987

South America

AR – Argentina, Buenos Aires

Tel: +54 3327 44 4129

BR – Brazil, Sao Jose dos Campos

Tel: +55 800 727 5374

CL – Chile, Santiago

Tel: +56 2 623 1216

MX – Mexico, Apodaca

Tel: +52 81 8156 6000

European Product Information Centre

Free phone: 00 800 27 27 5374

(from AT, BE, CH, CZ, DE, DK, EE, ES, FI, FR, IE, IL, IS, IT, LU, MT, NL, NO, PL, PT, RU, SE, SK, UK, ZA)

Parker Hannifin Manufacturing Ltd

Pneumatic Division Europe

The Collins Centre,

Lichfield South, Wall Island,

Birmingham Road, Lichfield.

WS14 0QP United Kingdom

Tel.: +44 (0) 1543 483800

Fax: +44 (0) 1543 483801

www.parker.com/euro_pneumatic

