

[Click here to view bookmarks.](#)

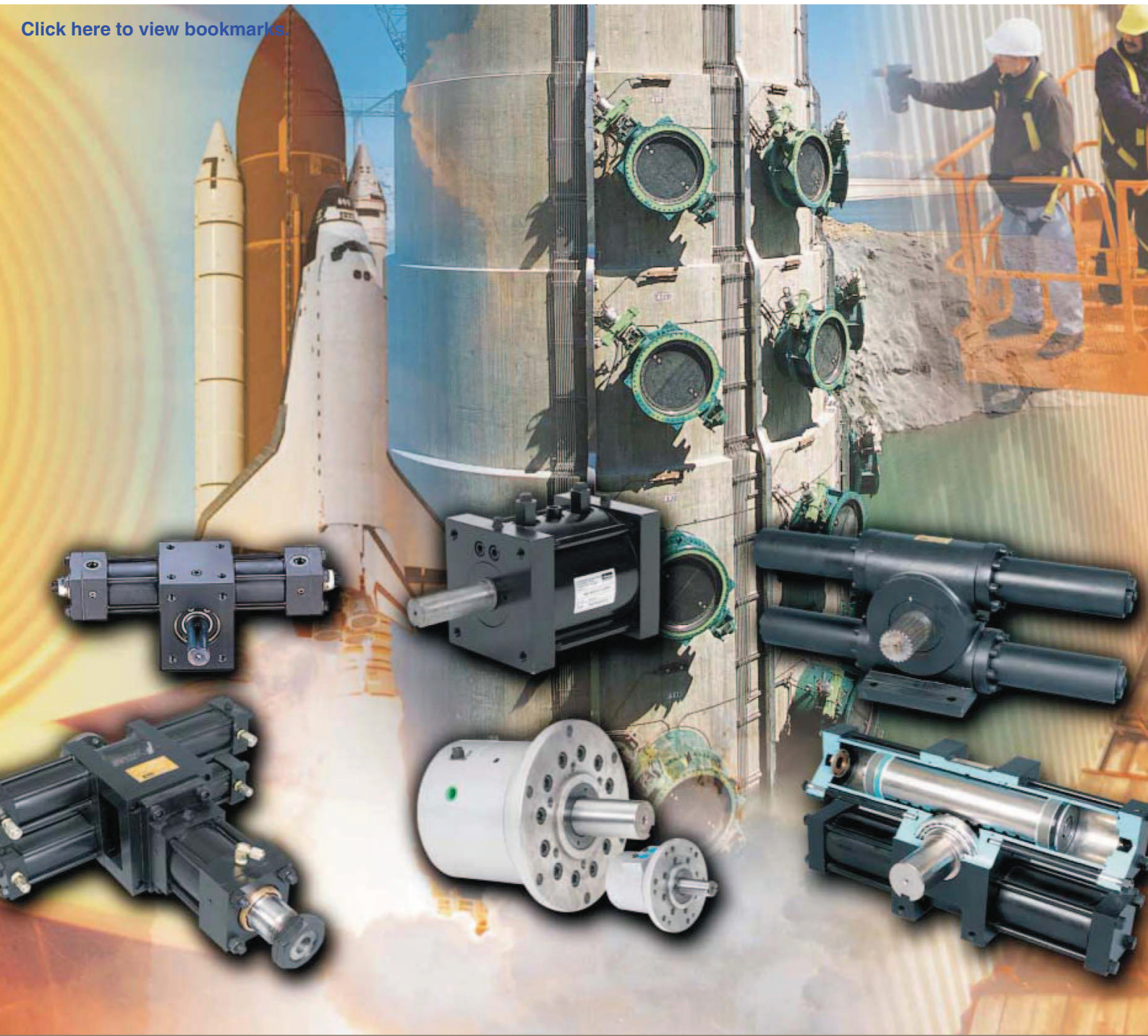

# Hydraulic Rotary Actuators

Catalog HY03-1800/US

aerospace  
climate control  
electromechanical  
filtration  
fluid & gas handling  
**hydraulics**  
pneumatics  
process control  
sealing & shielding



ENGINEERING **YOUR** SUCCESS.



**Parker Hannifin is the leading global manufacturer of components and systems designed to control motion, flow and pressure in all types of machinery. Parker is a Fortune 300 corporation listed on the New York Stock Exchange as PH.**

Parker offers more than 1,400 product lines that control motion in 1,000 industrial, mobile and aerospace markets. We are the only manufacturer to offer our customers a choice of hydraulic, pneumatic, electromechanical and computer motion control solutions. Furthermore, we have the largest global distribution network in our field, with more than 7,500 distributors serving more than 422,000 customers.

The Pneumatic Division is Parker's primary source for linear actuators, end effectors and structural framing used in machine structures and guarding systems. Additionally, Pneumatic Division offers products that use electromechanical, pneumatic and hydraulic technologies and has developed a business model that is based totally on customer needs. Hydraulic Pneumatic Division customers select the level of integration that best meets their needs.

Ordering an actuator or structural framing solution from Parker brings with it all of the benefits you have come to expect: quality, solution integrity, worldwide distribution and extensive field and customer support. Add supplier reduction, shorter lead times, simplified ordering and more efficient shipping and you'll agree that Parker's total solution capabilities are designed with your specific application in mind.



*Contact Parker Pneumatic Division with your specific requirement, and our engineers will be pleased to work out the details of your design.*

### **Application Engineering Help**

Parker Pneumatic provides premier application engineering services to our customers. Our engineers have detailed understanding of our products to help your staff select the appropriate actuator for any application. Parker designs and manufactures all major types of rotary actuators. Due to this broad base, we can offer the customer the optimum solution. Your engineers also can work independently with our user-friendly catalog and our computer-based analysis and selection tools. The actuators can be sized to meet the specific performance aspects of the application. Additionally, only the

Pneumatic Division provides information that allows the engineer to assess life requirements for the actuator. The engineer can precisely select the actuator that will provide the correct level of torque output over the full anticipated duty cycle life of his equipment. This ensures that the customer gets trouble free operation throughout its service life, avoiding expensive, unanticipated downtime. The ability to predict the operational life of the unit allows the customer to institute regularly scheduled preventative maintenance programs, maximizing production uptime. This is an additional value that Parker Pneumatic Division brings to the application.



## **Steel Industry**

This world of extremes presents many unique challenges for equipment used for automating critical processes.

Parker hydraulic rotary actuators are a vital part of the steel making industry. Unlike a cylinder, the hydraulic rotary actuator is completely enclosed in a rugged steel housing that protects critical working elements from the harsh and contaminated environment of the mill.

In addition to a broad, standard line of small actuators suitable for a variety of tasks, Parker's large precision units supply millions of in-lbs of controlling torque to tip and control the ladles of molten steel. Other applications include coil-box actuators and actuators used in walking beam arrangements to move large red-hot structural shapes through cooling beds. Parker also offers the M Series of actuators specifically designed for the mill environment. The M Series offers the high reliability, durability, and ease of maintenance so important to ensuring uninterrupted production.

## **Alternative Energy**

To meet economically viable cost targets (\$/kWh) that compare to those of fossil-fuel power supply solutions, solar-power equipment suppliers look for innovative engineering solutions that provide maximum efficiency combined with low cost. Parker has designed and supplied specialized actuators optimized to stringent performance requirements. The highly efficient rack-and-pinion gearing at the heart of actuator systems provides high power at low rotational speeds. The actuator is capable of driving the maximum number of solar panels under high wind conditions at a slow speed, allowing precision tracking of the sun. The low maintenance, stand-alone system has an integrated fluid reservoir and offers variable drive speeds if multiple pumps are used.



## **Boomslewer and Large Actuators**

The world's largest hydraulic rotary actuator was supplied to the shipbuilding industry for self-unloading freighters plying the Great Lakes and the oceans of the world. The Boomslewer actuator generates 64 million in-lbs of torque to precisely control and position the ship's 120-meter long cargo-conveyor boom. The actuator housing structure is an integral part of the ship's structure and is designed to absorb the megaton loads induced by the cargo conveyor, the loads caused by the wind, and the ship-listing loads

acting on the boom. The actuator has a self-contained reservoir, hydraulic power supply, and control valving, and is manufactured to the exacting requirements of the American Bureau of Shipping and Lloyds.

We have supplied hundreds of these actuators to a variety of domestic and overseas customers around the world during our 35-year history. Parker's worldwide support network assures effective communication, provides for successful coordination of technical and business requirements, and guarantees smooth delivery through export and import processes.



## **Marine and Submerged Applications - Water Control Management**

The Pneumatic Division of Parker Hannifin has furnished specialty actuators for submerged and marine operations for 35 years. It supplies the US Military with actuators to automate valves, deploy antennas, open and close torpedo doors and hatches, and to perform other tasks. Most of these actuators are custom-made to meet specific requirements.

Our largest Tork-Mor vane-type actuator operates the pool gates for the Shamu Seaworld attraction. Our HTR and M Series units are used in gantry and boom actuation functions on ships. Our actuators also are built into steering systems on surface ships and into vane control on submersibles.

Some actuators are approved by municipal engineers for use in major metropolitan areas for storm-water, potable-water, and flood-gate control. Our most recent application applied our HTR300 rack-and-pinion actuator, rated for 3000 psi and 300,000 in-lbs of torque, to position 48-in. butterfly valves while submerged to 150 feet in fresh water. These units were equipped with position feedback and sensor packages rated for depth. The rugged reliability of these heavy-duty actuators allows them to absorb the load and shocks of a seismic event.

## **Offshore Technology**

Parker technology is in demand in the offshore industry in a variety of areas. Actuators of varying sizes and with multiple specialized features provide reliable, effective, and low-cost solutions to the unique world of offshore rigs. Our HTR300 and HTR600 units are used in cable-winch and handling systems on both surface ships and offshore installations. We supply special actuators for large processing valves, some requiring 4 million in-lbs of operating torque.

Electrohydraulic valve actuators in sizes from 1800 in-lbs to 75,000 in-lbs are used regularly in oil-tank vent and shutoff valves, and in precision control of process fluids.

We recently designed and certified API 16C actuators that meet the stringent requirements for choke and kill systems within the oil industry.

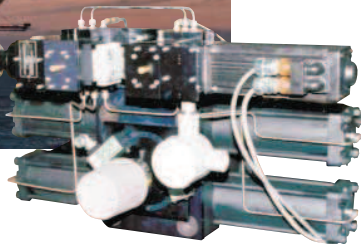

## **High Tech Applications**

Some of the most demanding actuator requirements come from customers that lead our nation's space program. Parker Pneumatic Division has been a proud supplier of specialty actuators for rotating umbilicals, multi-ton maintenance platforms, and blast doors on launch towers at Kennedy Space Center and the Vandenberg Air Force Base.

Another recent example of the Parker engineering team's diverse capabilities is its work with the engineers specifying equipment for the next-generation neutron-science facility at the Oak Ridge National Laboratory. The Spallation Nuclear Source is where a 2 MW proton beam blasts atoms, and where product safety and reliability are as important as performance and function. Two specialized actuators rated for 3000 psi and generating 3 million in-lbs of torque assure reliable opening and closing of a 75,000-lb steel-protection door on the target hot cell.



### **Mobile Applications - Trucks, Man Lifts**

Parker actuators are used in a variety of mobile applications. We can integrate actuators with power units from Parker Oildyne Division and valves from Parker's Hydraulic Valve Division to supply a single-source, drop-in, stand-alone system. Some fire trucks use this system to position ladders for easy access, while some buses and vans use it for deployment of handicap access ramps.

The enclosed, leak-proof piston seals make actuators ideal for applications where holding a load hydraulically is a critical requirement. The safety and reliability of Parker actuators assure precise manipulation of man-lift baskets in the construction

industry. Other actuators perform miscellaneous functions on oil-industry process trucks, refuse trucks, mobile X-ray scanner trucks for homeland security, vacuum truck cable reels, and dump truck load covers.

In the mining industry, HTR and M Series units see use on diverse applications, from small mobile-roof bolters to giant tunnel-boring machines requiring 6 million in-lbs of torque. Fork-lift steering and mobile-industrial transporters are examples of actuator applications in the factories. The aircraft industry uses actuators on machines that test A380 front-gear steering and those that dump fire retardant from aircraft-mounted tanks, as well as on gyrating flight simulators.

### **Process Industry**

The processing industry has many operational and environmental situations where actuators must function under adverse loading and severe thermal, shock, or environmental conditions. On rubber-mixer machines, heavy-duty actuators rated at 3000 psi and supplying torques from 75,000 to 300,000 in-lbs not only satisfy high static loads, but accept the punishment of shock loads. In these applications the actuator acts as a damping mechanism that absorbs high-production speeds for door actuation. Many major automotive tire manufacturers specify the 300M Series units as preferred equipment. The units provide the Mill rating, long life, durability, and ease of maintenance that are

recognized as providing the best value in the hydraulic rotary-actuator market.



Internal Intensive Mixer courtesy of Kobelco Stewart Bolling, Inc. Hudson, Ohio

# The Parker 3-Year Extended Warranty

Parker Hannifin Corporation will extend its standard limited warranty on **ALL** Hydraulics Group components to thirty-six (36) months if they are protected by properly installed and maintained Parker hydraulic filters. Components covered by this warranty include all cylinders, valves, and hydraulic components manufactured by Parker in any of our global facilities. This warranty covers our components, anywhere in the world you may ship your equipment.

Parker's obligation under this warranty is limited to the replacement or repair of any failed components. The buyer understands that the seller will not be liable for any other costs or damages.

The buyers of quality Parker components and filters benefit by having **ONE** source for all hydraulic needs: **Parker**.

*Lee C. Banks.*

Lee C. Banks  
President  
Hydraulics Group



**Parker's Extensive Hydraulic Product Line**

## Custom Engineering



Parker offers the broadest range of automation products in the industry, most of them presented as catalog items with standard performance limits and rigidly established dimensions and interfaces. Parker Pneumatic Division can offer much more than this. Parker Pneumatic Division is continuously investing in product improvements and upgrades that bring value to the customer or address specific customer needs. Many of these new ideas and customer inputs are developed from working directly with new customers on custom designed actuators. Our engineering and sales team welcomes your input and looks forward to helping develop products meeting your specific needs. Parker Pneumatic Division is the industry leader in actuator technology. We have invested in the engineering and analysis tools to fully understand the limits of our product offerings. We have the team in place and the analysis and technical capabilities to evaluate your special requirements and to work with your engineers to establish an optimum solution.

Rack-and-pinion actuators offer the opportunity for the customer to define and integrate specific features or strengths into the actuator housings. If required, special actuator housings can be fabricated from a machined block or a weldment versus the standard cast housing. This special housing can be designed with special dimensional features and strength capabilities to integrate directly into the customer's structure. The actuator assembly thus becomes a drop-in device with precision-machined features defined by the customer, built-in bearing capability, and other critical features in addition to supplying rotary power and positioning. These values are incorporated into one low-cost package the customer can buy, without doubling up on the expense of building similar features into his apparatus.

A summary of other specialty features successfully designed into rack and pinion actuator products are as follows:

- Housing and shafting with special materials and features designed to carry high loads.
- Actuator features recognized industry wide for providing durability, long life, and reliability of 99% in 10 million cycles
- Rotations to 1080°, variety of speeds, special shafting, mounting, and porting accommodations.
- Units with minimal backlash, plus combined linear and rotational motion
- Units integrated with control-valve packages, and position feedback for total system solutions
- Special materials – titanium, monel, stainless steels, bronzes, composites
- Compliance to customer specs and agency certifications – ABS, FDA, military, UL/CE, SAE, and API 16C certification
- Special environments and applications – robotic, submerged, clean room, medical, PC chips, and corrosive atmosphere

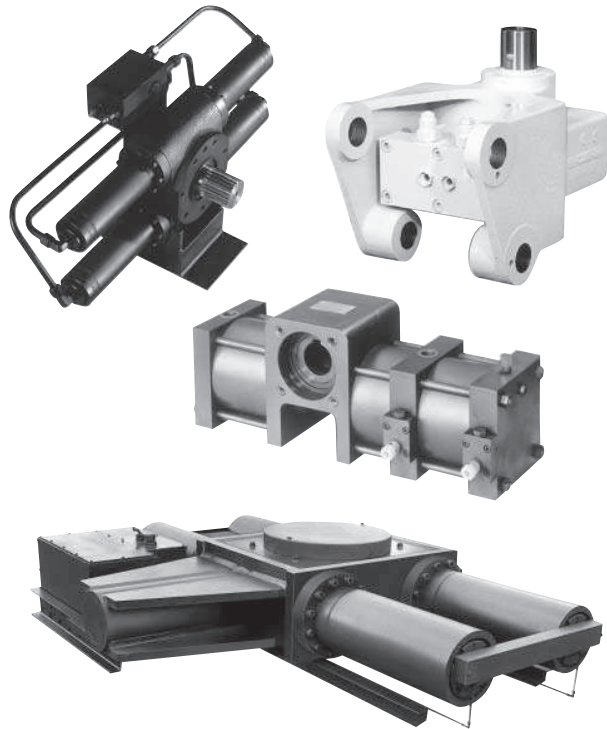

**Integrated Hydraulics Packages from Parker Worldwide**

Parker is a worldwide corporation having 44 different Divisions and offering thousands of products. Because of the broad spectrum of product in all types of automation technology, we are able to formulate innovative solutions to new or complex problems. We pride ourselves on having the expertise to work as a team with customer's technical personnel, Parker's field systems specialists, and a comprehensive network of distributors. We use these resources to pull together technologies from different Parker Divisions and to offer a fully integrated package to meet the customer's needs.

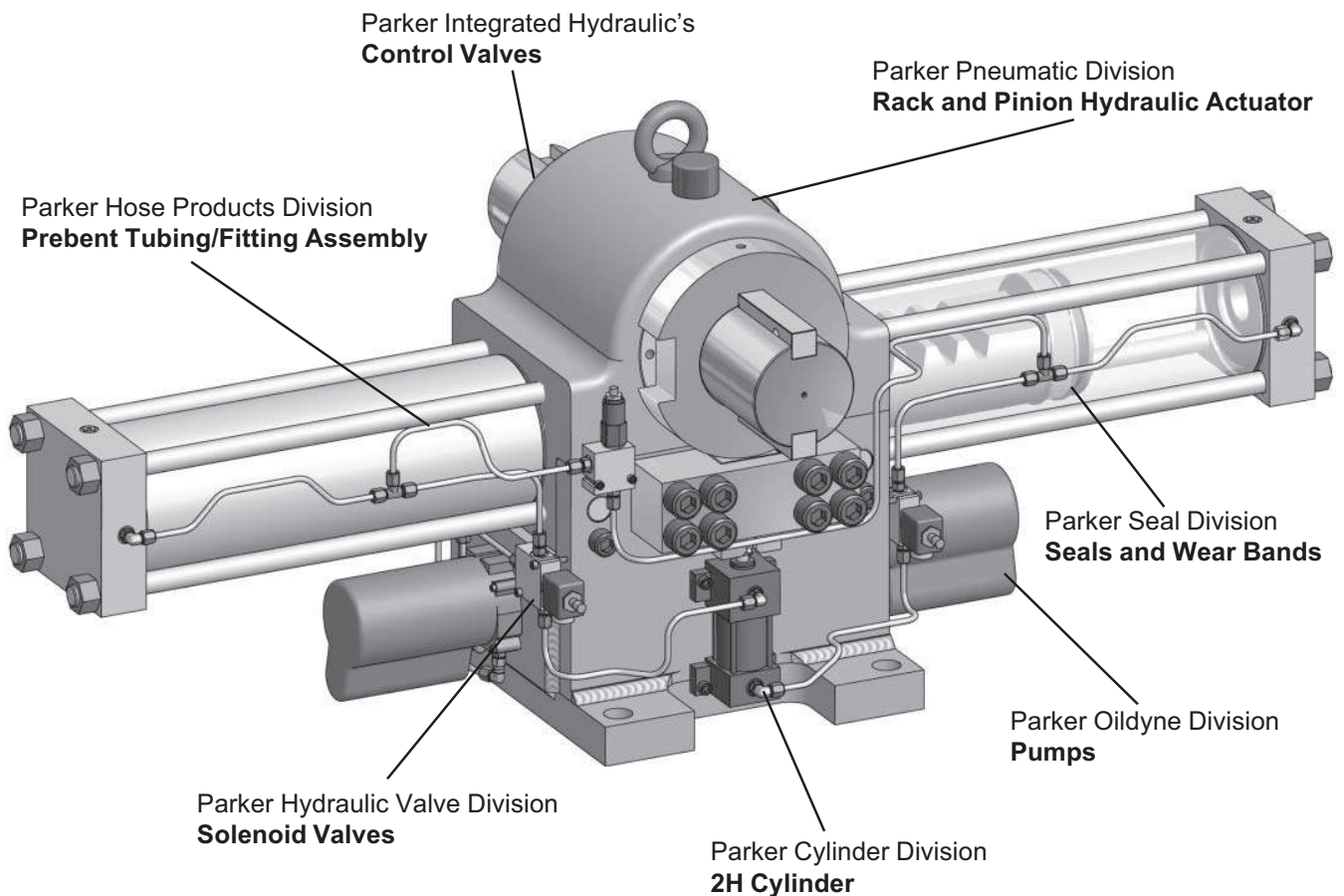



## Hydraulic Rotary Actuators Design Features

### Gears Materials Options and Hardness



Pneumatic Division has extensive experience in rack-and-pinion gear rotary actuator technology that can be quickly applied to satisfy specific customer needs.

All gears are designed to provide long life and durability. Standard gears and racks are fabricated from thru-hardened alloy steel selected and specified in accordance with the American Gear Manufacturers Quality Class 6-10. High-quality alloy steel is rigorously inspected to achieve compliance with the AGMA quality class. Each actuator size has gearing incorporated that achieves the rated torque without breakage. Data is presented for every size of actuator gearset to allow proper selection for long production-cycle life without adverse wear out. Gearing can also be custom designed to achieve specific loading and life characteristics. Options include improved materials, surface treatments for high hardness and extended wear under extreme loads and speeds, specialized lubricants, and others.



### Reliability, Durability Features

Pneumatic Division manufactures a wide variety of rotary and linear actuators. The HTR Series of heavy-duty hydraulic rack-and-pinion rotary actuators are

recognized for rugged durability and life. These are used extensively in a wide variety of applications where high reliability is considered of key importance to maintaining production-line output without downtime, or to achieving mission-critical functionality. These actuators utilize time-proven design concepts and materials to produce a product unique in the industry. Their large tapered-roller bearings support high external radial and thrust loads. The tie-rod cylinder construction complies with NFPA heavy-duty, Series 2H certification requirements. The gearing is manufactured to AGMA standards. Proprietary analysis programs are employed to demonstrate reliability rates of 99% in 10 million cycles in special cases, as requested by customers. The analyses results have also been incorporated into Catalog 1800/USA, and offer the customer the ability to easily select actuators meeting both performance and durability requirements.

### Lightweight Versions of the HTR Line

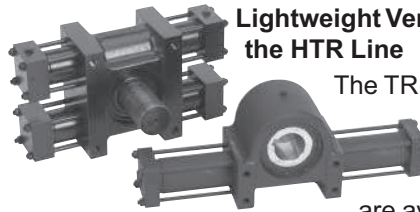

The TR products offer a specialty option for a light-weight actuator. Two sizes are available. The TR15

and the TR30 are single-rack and double-rack designs rated for 15,000 in-lbs of torque and 30,000 in-lbs of torque at 3000 psi. These units have aluminum housings and end caps and are used in applications where weight is critical. A precision-machined and anodized housing surface acts internally as a rack bearing surface and premium bronze bushings support the pinion shaft. The pistons are precision machined from non-ferrous materials to prevent scoring of the cylinder walls during operation. The TR Series performs well in applications where the customer wants pure output torque from the actuator and external customer loads are supported by the customer's structure. Contact the factory for specific information on this model.

### Lubrication

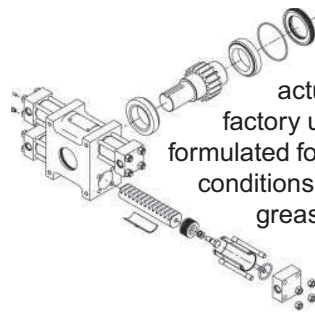

Each hydraulic rotary actuator is greased at the factory using specialized gear grease formulated for the typical operating conditions seen in the field. The type of grease is a multi-purpose, extra pressure (EP) lithium-based grease containing molybdenumdisulfide as a solid lubricant. At the factory, the rolling-element bearings are packed at assembly and the gear case is filled to approximately 75% full. At normal speeds and operation within the life rating of the actuator, the unit will provide trouble-free service without additional lubrication. If the unit is disassembled for standard seal maintenance, it needs to be repacked and relubricated.

The gear housing is equipped with a relief valve that is set to vent pressure from the gear case in the event of piston-seal bypass prior to seal maintenance. The vent relief provides a visual indication that seal maintenance is required since some grease will be forced through the vent fitting.

## Hydraulic Rotary Actuators Design Features

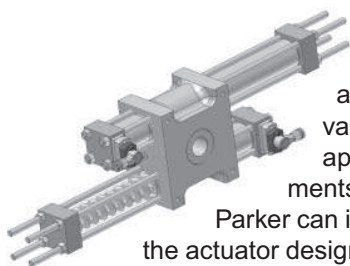

### Spring Return

Parker hydraulic rotary actuator units perform well as valve operators. Many valve applications have requirements for fail-safe operation.

Parker can incorporate this function into the actuator design. This is accomplished by selecting a double rack unit sized so that the single-rack torque capability is appropriate to operate the valve and overcome the maximum spring-return force generated. The double-rack configuration uses two cylinders to house the selected return spring and the remaining two cylinders for the hydraulic power cylinders. The unit can be designed with a variety of shaft options and mounting options to accommodate the customer connection.

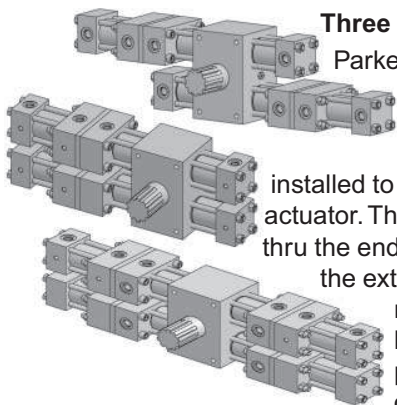

### Three Position HTR

Parker can provide an intermediate stop position on an HTR by combining a number of 2H cylinders installed to the end caps of the actuator. The cylinder rods extend thru the end cap and are stroked to the extend position to trap the rack-and-piston assembly in the intermediate position. This design configuration applies to

both single-rack and double-rack units. Different combinations of cylinder-rod extension length vary the intermediate stop position. The force ratings of the cylinders can be selected to match the full torque output of the unit at all positions. For double-rack units, four 2H cylinders can be used and provide full output torque. If full double-rack output torque isn't required at the intermediate position, two 2H cylinders can be mounted at various actuator-cylinder locations to reduce the overall size and cost of the unit.

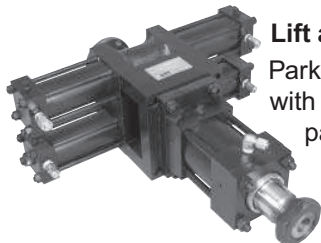

### Lift and Rotate

Parker can combine linear motion with rotary motion in one compact package. Specify the combination of lift force and lift distance that you would like to combine with a torque rating and rotation angle, and

Parker engineers can select the appropriate 2H cylinder to combine with the right actuator from the HTR Series. Because these are specialty units, we can supply a one-piece, precision-machined package that drops into your installation with mutually coordinated interface dimensions, porting definition, and drive-shaft features.

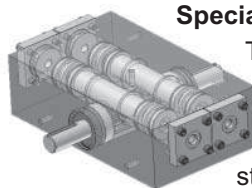

### Specialty Housings

The rack-and-pinion actuators offer the opportunity for the customer to define and integrate specific features or strengths into the actuator housings. If required, special actuator housings can be fabricated from a machined block or a weldment versus a standard cast housing. This special housing can be designed with special dimensional features and strength capabilities to integrate directly into the customer's structure. Thus, in addition to supplying the rotary power and positioning function, the actuator assembly becomes a drop-in device with precision machining features defined by the customer, built in bearing capability, and other critical features. These values are incorporated as one low cost package the customer can buy, without doubling up on the expense of building similar features into his apparatus.

### Efficiency

The most efficient actuator type is the rack and pinion. The efficiency of this spur-gear actuator is high, typically in the low-to-mid 90th percentile. This offers advantages for the overall hydraulics system size since the actuator displacements are minimized and the size of the required Hydraulic Power Unit (HPU) pump, motor, and reservoir can be minimized. This means less cost. Additionally, system inefficiency is important in applications with high-speed production cycles since the inefficiency produces rapid heating of the fluid. To control this, a heat-exchange system is required, adding cost and complexity to the application. Vane-type actuators have efficiencies around 70%, and helical types are only about 55% efficient.

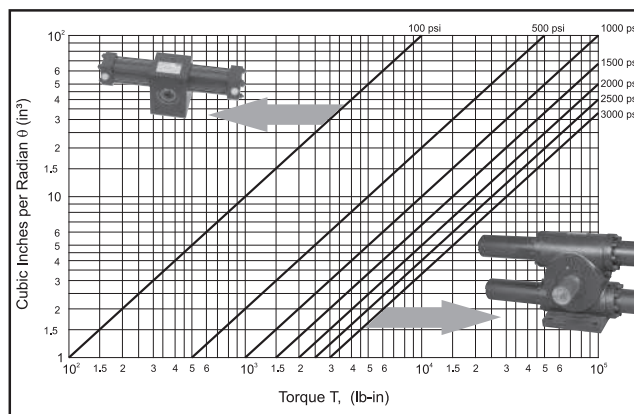

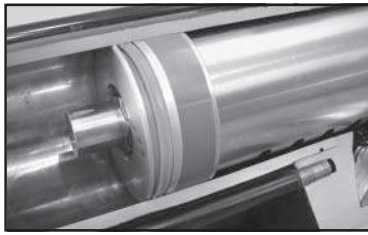

**Seals**

Pneumatic Division is continuously investing in product improvements and upgrades that bring value to the customer. Our most recent improvement

is on the dynamic piston-and-pinion shaft seals, where we see high wear and contamination conditions. We have applied dual-lip seal technology to enhance seal life. This proven technology has been used successfully on cylinder-rod seal applications for gears. Head-to-head testing against polymer seals demonstrates life improvement by factors of 2 to 4. The abrasion toughness of the new material enhances contamination resistance. Dual-lip technology improves seal performance in two ways. The double lip minimizes leakage and traps minute amounts of fluid against the seal lips for lubrication.

The new pinion shaft seals are capable of longer life at higher pressure. These seals traditionally have been o-rings that seal effectively at low delta pressures in the grease-packed gear case. However, in the event of piston-seal wear over time, hydraulic pressure leakage to the gear case can cause case pressures of 650 psi. The single lip of the o-ring in this dynamic application has limited life. We have incorporated dual lobed seal technology at this interface as well. The new seal fits into the same grooves, but operates at a lower compression squeeze than the equivalent o-ring. The dual-lobed seal thus sees less wear from the pinion shaft during its dynamic life and operates more effectively at the higher pressure during piston-seal bypass.

**Specialty coatings**

All units from the Parker Pneumatic Division come from the factory with a standard corrosion protection coating of black waterborne acrylic polymer paint. The coating complies with various ASTM standards for solvent, impact, and chemical resistance as well as salt spray.

Parker can also offer specialty treatments suitable for different environments such as sea or fresh water, high humidity and temperatures, or corrosive fluids encountered in various processing industries.

Alternatively, Parker fabricates actuators entirely from stainless steel when this highest level of protection is required. Specialty protective processes may be selected based on coordination with the Parker engineering department.



**Wear Bands and Rack Bearings**

Most actuator applications operate at fairly slow velocities. For example, speeds up to one radian/sec (approximately 60 degrees/sec) are typical. Many actuators operate at higher speeds, however. This subjects the critical surfaces in the unit to high sliding velocities and contact loads that can lead to fast and catastrophic failure of the unit if not properly considered. Parker understands the engineering specifics within the actuator and has developed proprietary analyses tools that allow us to examine the customer's special operating conditions and make recommendations regarding them. We can offer options for the wear-band materials and the rack-bearing materials, as well as configurations to satisfy higher speeds and loads. Options that we have successfully applied include rack bearings made of premium bronze, composite, and pre-lubricated graphite. Similarly we can offer premium wear-band materials or composite wear bands, depending on the application requirements.

**Factory Acceptance Testing**

Every unit undergoes several test sequences prior to shipment from the factory. Each lot of actuators has test documentation completed and kept on file. Specific additional testing if required by the customer can be quoted and done, with QC documentation packages supplied if required. Each unit is marked with a nameplate having model number, pressure rating, and serial number that must remain on the unit to maintain the warranty.

**Inphorm Analysis Software**



Parker recognizes the complexity associated with selecting and sizing hydraulic rotary actuators. Our application engineers can assist you with this.

Additionally, our Catalog HY-03-1800/US includes a detailed engineering section that provides an in-depth explanation of the critical considerations for selecting the appropriate actuator. The Engineering Guidelines section defines the applicable equations and nomenclature and provides sample problems on how to model real life applications. We supplement the catalog with software that is interactive and allows the user to easily apply those basic principles to different combinations of operational parameters.

***Fax completed form to (330) 334-3335***

**CONTACT INFORMATION:**

**Name:** \_\_\_\_\_ **Phone Number:** \_\_\_\_\_

**Company:** \_\_\_\_\_ **Fax Number:** \_\_\_\_\_

**Address:** \_\_\_\_\_

**APPLICATION DETAILS:**

**1. Torque Requirement:** \_\_\_\_\_ **lb-in.**      **2. Operating Pressure:** \_\_\_\_\_ **psi**

**3. Required Rotation:** \_\_\_\_\_ ° (i.e. 90°, 180° etc.)      **4. Cycle Time:** \_\_\_\_\_ **sec.**  
(Time to complete rotation in one direction)

**5. End of Stroke Options Required:** \_\_\_\_\_ (i.e. Cushions, Stroke Adjusters)

**6. Bearing Support Required** - Include weight of external load and direction in which it will be applied. (i.e. radial, thrust)

\_\_\_\_\_

**7. Operating Temperature:** \_\_\_\_\_ °F      **8. Type of Fluid Used:** \_\_\_\_\_

**9. Brief Description of Application** (If needed, sketch can be submitted using the space provided at the bottom of this page.)

\_\_\_\_\_

**ACTUATOR DETAILS:**

**1. Type of Mounting Style Preferred:** \_\_\_\_\_

**2. Type of Shaft Connection Preferred:** \_\_\_\_\_

**3. Any Special Options Desired?** \_\_\_\_\_

\_\_\_\_\_

**SKETCH:**

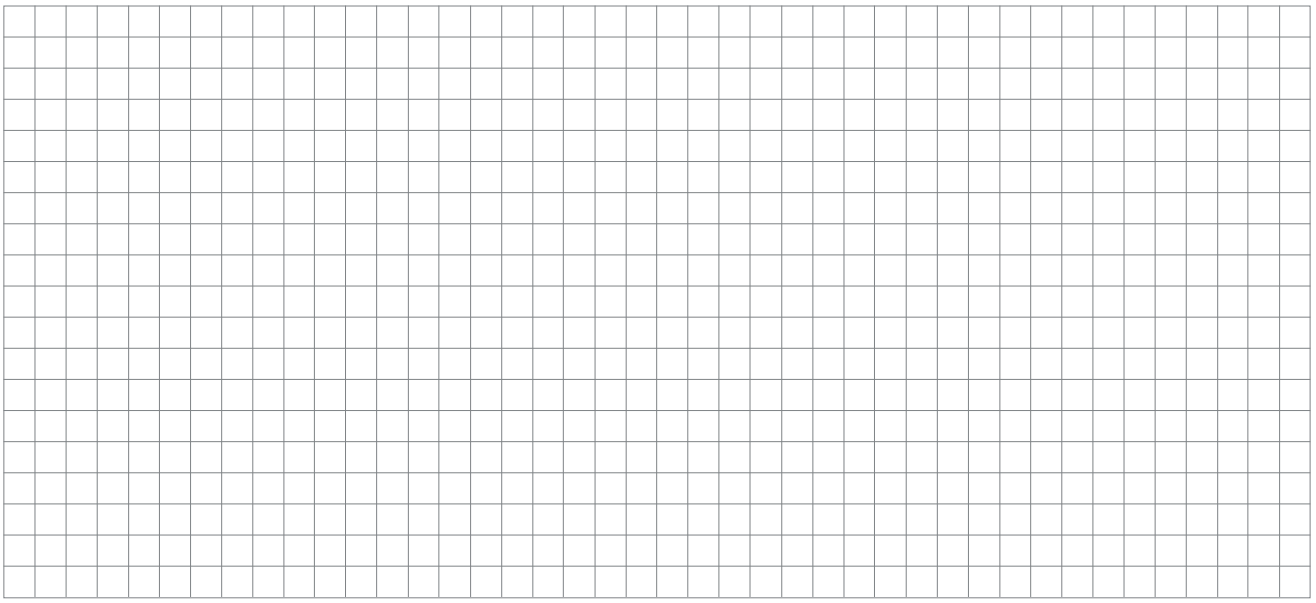

## Introduction

- Product Overview
- Rack & Pinion Selection Guide
- Application Examples

Intro

## LTR Series



Light Duty Rack and Pinion

LTR

## HTR Series



Medium Duty Rack and Pinion

HTR

## M Series



Mill Duty Rack and Pinion

M

## HRN/HRNC Series



Vane Rotary Actuators

HRN

## Tork-Mor Series



Heavy Duty Vane Style Rotary Actuators

Tork-Mor

## Sensors & Feedback

- Solid State Sensors
- Reed Switches
- Proximity Sensors
- Feedback Packages

Sensors & Feedback

## Engineering Guidelines

Engineering Reference and Equations

Engineering

## Service Bulletins

- Installation Instructions
- Maintenance Instructions
- Service Parts

Installation & Maintenance

**Parker . . .  
Leading the Industry**

Parker leads the industry in development of new and innovative features to make rack and pinion rotary actuators more reliable, efficient and safe. With a firm commitment to product quality and design research, Parker rotary actuators are continually being improved so that you can enjoy benefits such as long service life and increased productivity.

**What Is a Rack & Pinion  
Rotary Actuator?**

Parker rotary actuators convert fluid power into rotary motion for a wide variety of industrial applications. Pressurized fluid is applied to a circular piston inside a cylinder which pushes a rack across the pinion gear. This action turns the shaft, generating rotary motion. This motion is transferred through the shaft to the machinery for applications such as upending, turning, roll-over, tilting, indexing, transferring, mixing, valve operating, tensioning and clamping.

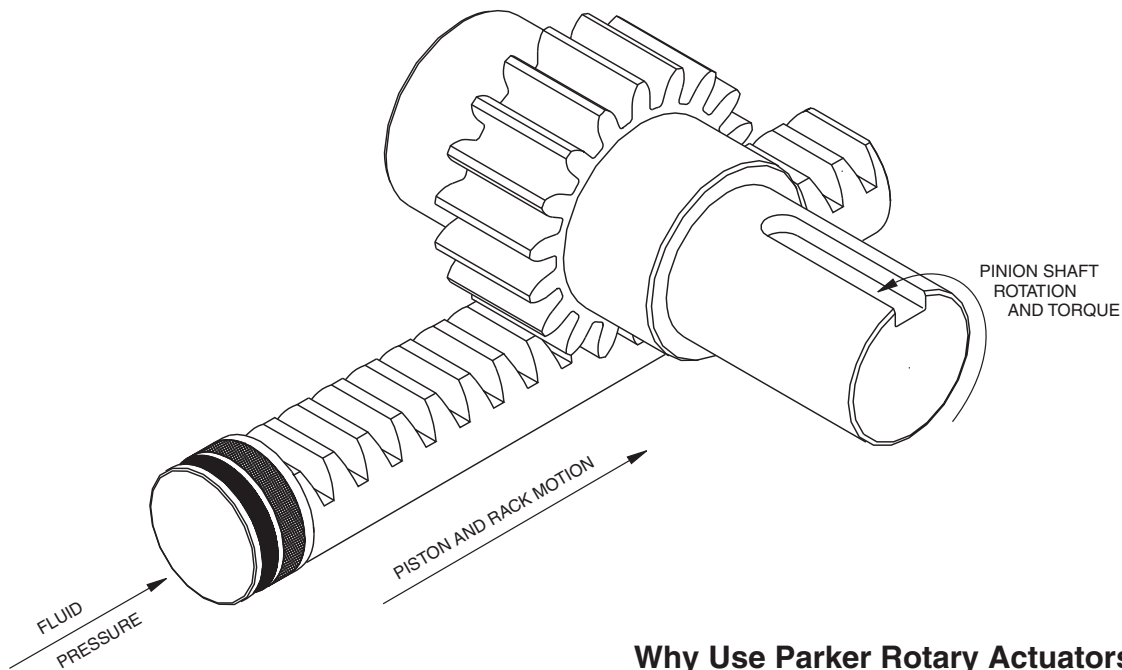

**Where Can Parker Rack & Pinion  
Rotary Actuators Be Used?**

- Material Handling
- Machine Tool
- Primary Metals
- Rubber and Plastics Machinery
- Mobile Equipment
- Robotics
- Packaging
- Valve Actuation
- Multi-Process Industry
- Cranes and Hoists
- Mining and Oil Field Equipment
- Military
- Commercial Marine

**Why Use Parker Rotary Actuators?**

- Provides uniform torque in both directions.
- Simple design.
- Wide range of sizes.
- High torque output in a small package size.
- More efficient operation and longer time between servicing.
- Performs under the most adverse ambient conditions.
- No external linkage needed for rotary motion.
- Good load holding capability with no drift.
- Optional cushions can stop inertial loads\*.
- Rotation can be specified to fit exact application needs.
- Will support radial and thrust loads.

\* Within actuator limits.

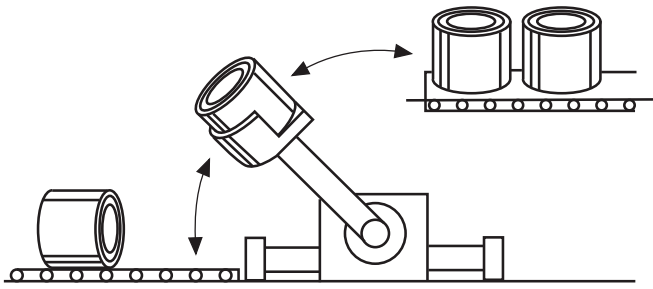

**TRANSFER  
(UPENDING/DOWNENDING)**

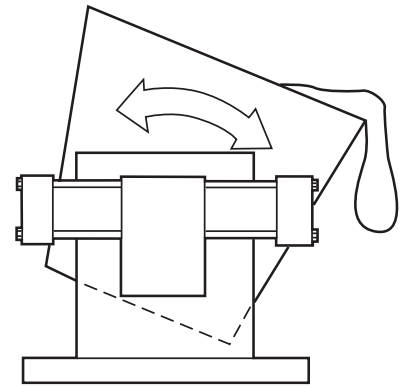

**UNLOADING/DUMPING**

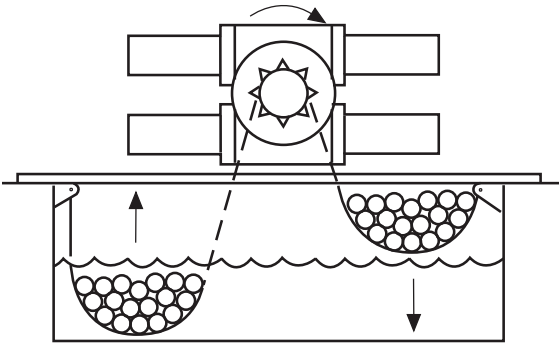

**TUBE PICKLING DRIVE CONVEYOR**

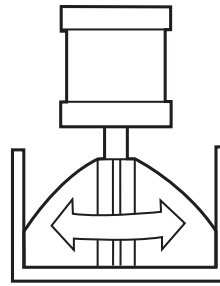

**MIXING**

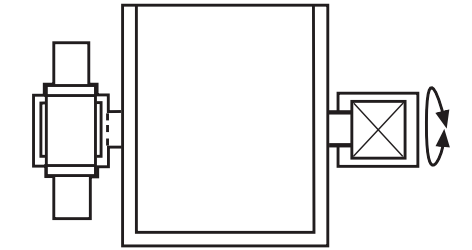

**WELDING FRAME ROLLOVER**

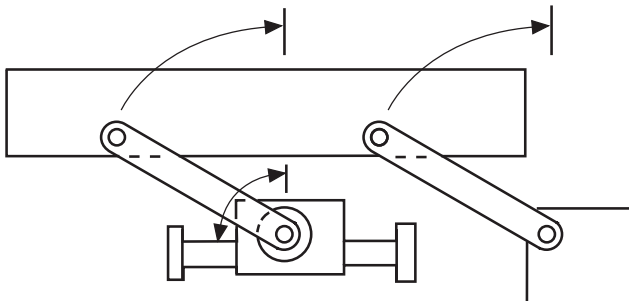

**TRANSFER  
(LIFTING/FEEDING)**

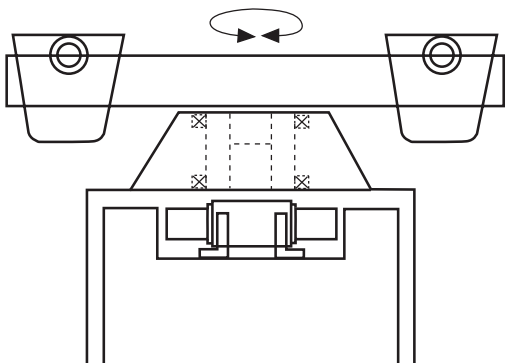

**LADLE TURRET**

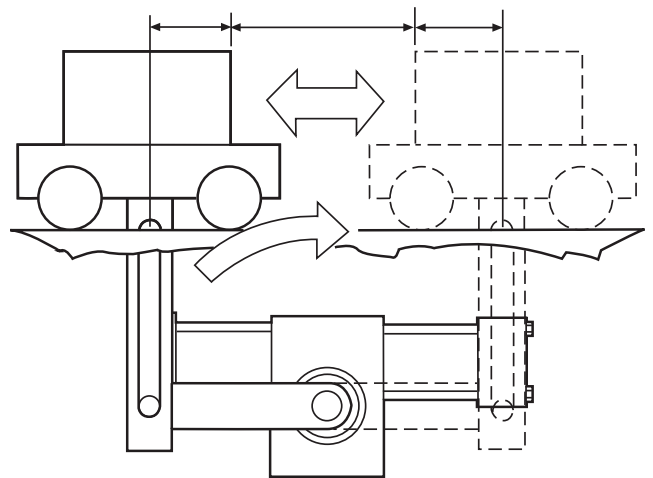

**HARMONIC DRIVE**

A rack and pinion rotary actuator consists of a housing with bearings, a rack and pinion gear rotary group and hydraulic cylinder parts. The cylinder pistons drive the rack gear across the pinion gear to generate torque at some rotational velocity. Gear tooth life is well understood and with the help of the AGMA 2001-B88 calculation model, we can make gear train life estimates. The following tables suggest a relationship between a desired total torque value and a desired durability cycle life.

**Durability Cycle Life**

A gear tooth can break either when overloaded or by load induced metal fatigue. The tooth overload failure mode is obvious. Parker and our competitors have historically used the "bending stress" criteria to establish torque ratings. Tooth bending capability remains a useful criteria. Parker proposes to broaden the selection criteria by publishing torque versus durability life guidelines and suggestions. Parker Automation Pneumatic Division has generated the following tables as an actuator selection aid. We suggest actuator selection begin with the consideration of both torque and desired durability life. Use these tables to discover possible candidate LTR, HTR and Mill type actuators for consideration.

**How to Use**

These suggestions are made not respective of the available operational pressure. Select the desired total torque requirements on the left hand column. Then select the desired durability cycle life column. In that square, find an actuator suggestion that should meet both the gear train durability and cycle life criteria. An actuator with greater capabilities than the one suggested should satisfy the same criteria. For example, if the block suggests an LTR151 for the given torque and durability life, then an LTR152 is also suitable as would be an HTR1.8 or any actuator larger than the LTR151.

**Caution:** These charts are intended as a guide only. Refer to actual product data in the catalog before specifying an actuator. Factors such as bearing loads and shock loads may influence actuator selection. It is not feasible for any catalog to note, describe and anticipate all product limitations. It is incumbent upon the OEM or user to qualify any particular product for each and every application.

**NOTE:** Consult factory for gear train life information if:

- LTR system pressure exceeds 750 psig
- HTR system pressure exceeds 1750 psig
- M system pressure exceeds 2250 psig

Completely fill out the "Application Fax" and submit the form prior to contact with the factory.

**Torque vs Durability Cycle Life\***

Torques from 200 to 1100 lb-in

Torque Level		10 thousand Cycles Nominal Life	100 thousand Cycles Nominal Life	1 million Cycles Nominal Life	10 million Cycles Nominal Life
lb-in	Nm				
1100	124	LTR151	HTR1.8	HTR3.7	LTR152
1000	113	LTR151	HTR1.8	HTR1.8	LTR152
900	102	LTR151 or HTR.9	LTR151	HTR1.8	HTR3.7
800	90	HTR.9	LTR151	HTR1.8	HTR1.8
700	79	LTR102 or HTR.9	LTR151	LTR151	HTR1.8
600	68	LTR102 or HTR.9	LTR102 or HTR.9	LTR151	LTR151
500	57	LTR102 or HTR.9	LTR102 or HTR.9	LTR102 or HTR.9	LTR151
400	45	LTR101	LTR102 or HTR.9	LTR102 or HTR.9	LTR102 or HTR.9
300	34	LTR101	LTR101	LTR102 or HTR.9	LTR102 or HTR.9
200	23	LTR101	LTR101	LTR101	LTR101

\*Durability life estimates based on AGMA 2001-B88 gear life model for pitting resistance.



**Torque vs Durability Cycle Life\***  
 Torques from 2000 to 10000 lb-in

Torque Level		10 thousand Cycles Nominal Life	100 thousand Cycles Nominal Life	1 million Cycles Nominal Life	10 million Cycles Nominal Life
lb-in	Nm				
10000	1130	HTR10 or LTR321	LTR322	HTR30/45	HTR30/45
9000	1017	HTR10	HTR15/22	HTR30/45	HTR30/45
8000	904	HTR10 or LTR252	HTR15/22	LTR322	HTR30/45
7000	791	HTR7.5	HTR10	HTR15/22	HTR30/45
6000	678	LTR321/252	HTR10	HTR15/22	HTR30/45
5000	565	HTR5 or LTR202/252	LTR202/321	HTR10	HTR15/22
4000	452	LTR202/321	LTR202/321	LTR202/321	HTR10
3000	339	HTR3.7 or LTR251	HTR5	LTR202/321	LTR321
2000	226	HTR1.8 or LTR152	HTR1.8/3.7 or LTR152	LTR101/251/152 or HTR5	LTR321/HTR5/HTR7.5

**Torque vs Durability Cycle Life\***  
 Torques from 15000 to 100000 lb-in

Torque Level		10 thousand Cycles Nominal Life	100 thousand Cycles Nominal Life	1 million Cycles Nominal Life	10 million Cycles Nominal Life
lb-in	Nm				
100000	11300	150M or HTR150	150M	150M	150M or HTR300
90000	10170	150M or HTR150	150M	150M	150M or HTR300
80000	9040	150M or HTR150	150M	150M	150M or HTR300
70000	7910	75M or HTR75	75M	150M	150M or HTR300
60000	6780	75M or HTR75	75M or HTR150	75M or HTR150	150M or HTR300
50000	5650	75M or HTR75	75M or HTR150	75M or HTR150	75M or HTR150
40000	4520	75M or HTR75	75M or HTR150	75M or HTR150	75M or HTR150
30000	3390	HTR30	HTR75	75M or HTR150	75M or HTR150
20000	2260	HTR30/45 or LTR322	HTR30/45	HTR75	HTR75
15000	1695	HTR15/22 or LTR322	HTR30/45	HTR30/45	HTR30/45

**Torque vs Durability Cycle Life\***  
 Torques from 100000 to 600000 lb-in

Torque Level		10 thousand Cycles Nominal Life	100 thousand Cycles Nominal Life	1 million Cycles Nominal Life	10 million Cycles Nominal Life
lb-in	Nm				
600000	67764	600M or HTR600			
500000	56470	600M or HTR600	600M		
400000	45176	600M or HTR600	600M	600M	
300000	33882	300M or HTR600	600M or HTR600	600M	600M
200000	22588	300M or HTR300	300M	600M or HTR600	600M or HTR600
100000	11300	150M or HTR150	150M or HTR300	150M or HTR300	150M or HTR300

\*Durability life estimates based on AGMA 2001-B88 gear life model for pitting resistance.

### LTR Series

The LTR Series will provide superior performance in low pressure hydraulic applications found in packaging, material handling, machine tool and automated assembly industries.

Sealed ball bearings and floating pistons ensure low breakaway pressure and smooth operation. PolyPak piston seals and wearbands eliminate leakage and cylinder scoring. Alloy steel racks and pinions provide the strength and resilience for minimum downtime. A broad offering of options provides unmatched flexibility in design and application. These include cushions, stroke adjusters, flow controls, and position sensors, as well as application matched shaft, mounting, porting and seal variations. Three position and antibacklash units are also available.

### HTR Series

When durability, performance, and reliability are required in the most demanding industrial applications, specify the HTR Series actuator. This series is designed for medium duty service found in machine tool, transfer line, material handling and other critical applications.

Through hardened alloy steel pinion and racks, supported by large capacity tapered roller bearings in a ductile iron housing, ensure long life, even with externally applied radial and thrust loads. The heavy duty Wear-Pak pistons are equipped with self-energizing deep PolyPak piston seals and a rugged wear band for long life operation. Standard NFPA cylinder construction allows for a wide variety of rotation options, complementing the broad offering of shaft and mounting styles.

### M Series

Designed to meet steel mill specifications, these non tie rod rotary actuators incorporate a range of exclusive features designed to provide durability and dependability in the most arduous operating environment.

Wear band pistons on both ends and bronze bearings under the center of the alloy steel rack provide critical support and virtually eliminate scoring or galling of the cylinder tubes. Large diameter tapered roller bearings support the pinion, allowing the unit to absorb high external loads. PolyPak seals provide long life operation and, for ease of maintenance, can be changed without removing the actuator from the installation.

#### SPECIFICATIONS

- **Nominal Pressure:** 1000 psi
- **Standard Rotations:** 90°, 180°, 270°, 360°
- **Output Torque @ 1000 psi:** 395 to 22,500 lb-in
- **Maximum Breakaway Pressure:** 30 psi



#### SPECIFICATIONS

- **Maximum Operating Pressure:** Up to 3000 psi non-shock
- **Standard Rotations:** 90°, 180°, 360°
- **Rotational Tolerance:** -0° + 2°
- **Output Torque @ 3000 psi:** 900 to 600,000 lb-in
- **Maximum Breakaway Pressure:** 75 psi

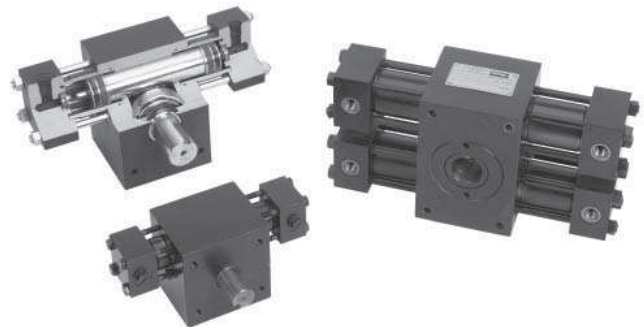

#### SPECIFICATIONS

- **Maximum Operating Pressure:** 3,000 psi
- **Proof Pressure:** 4,500 psi
- **Standard Rotations:** 90°, 180°, 270°, 360°
- **Rotational Tolerance:** -0° + 2°
- **Output Torque @ 3,000 psi:** 75,000 to 50,000,000 lb-in
- **Average Angular Backlash:** 10 minutes
- **Maximum Breakaway Pressure:** 100 psi
- **Housing:** Heavy duty ductile iron (units up to 1,000M), Steel weldments (units larger than 1,000M)



**Parker . . .  
Leading the Industry**

Parker combines many years of vane actuator experience with innovative product design to lead the industry in the development of reliable and efficient rotary actuators. When you specify Parker rotary vane actuators, you can rely on reduced maintenance costs and increased productivity.

**Why Use Parker Vane Style Rotary Actuators?**

- High torque output in a small package size
- Very economical for OEM applications
- Zero backlash allows precise positioning
- Provides uniform torque in both directions
- Simplicity of design
- Washdown compatible
- Performs under the most adverse ambient conditions
- Cleanroom compatible
- Guaranteed zero external leakage
- Will support radial and thrust loads
- Wide range of sizes

**Where Can Parker Vane Style Rotary Actuators Be Used?**

- Material Handling
- Machine Tool
- Rubber and Plastics Machinery
- Robotics
- Packaging
- Valve Actuation
- Food Processing
- Electronics Manufacturing
- Conveyors

**How Do Vane Actuators Work?**

Parker vane actuators provide the maximum amount of output torque from the smallest possible envelope size. They convert fluid pressure into rotary motion for a wide variety of industrial applications. Two basic styles are available. Single vane models have a maximum rotation of 280°, while the double vane units produce twice the torque output from identical envelope dimensions and have a maximum rotation of 100°.

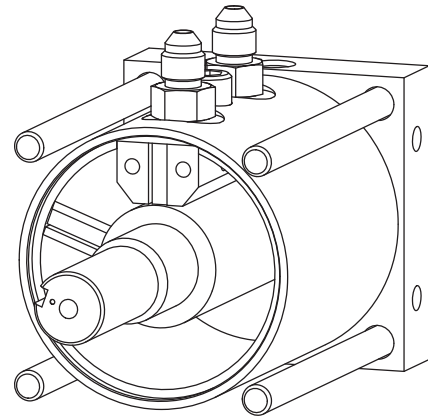

**Single Vane**

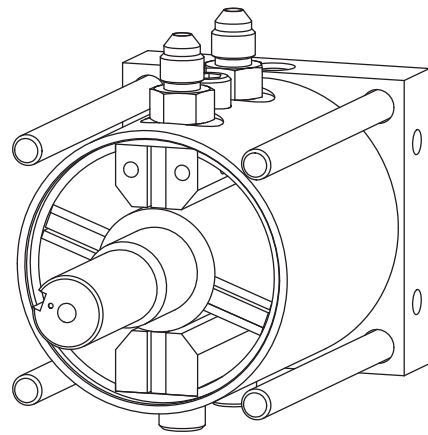

**Double Vane**

A short cylindrical chamber encloses a vane attached to a central shaft. Pressure is applied through a stationary barrier (stator) within the body to one side of the vane. The opposite side of the vane is connected to exhaust through the stator. This pressure overcomes seal friction and produces rotation of the vane and central shaft. Due to vane actuator design, there will always be some internal bypass in these units and therefore they should not be used as a brake to support loads.

### HRN Series

The HRN Series incorporates a rounded vane design, which provides lower vane seal bypass. The shaft and vane are machined from high strength alloy steel as one piece. The vane seal is molded in a pre-machined groove in order to provide a one piece shaft, vane, and seal assembly for long life and reliability. The standard rear output shaft provides for an easily accessible manual override in the event that hydraulic pressure is lost.

Reference points (or keyway timing) are provided relative to the port positioning. Large, convenient, front flange with precision pilot diameter allows for concise mounting and easy integration with the customer's application.

The HRN-C Series provides an additional range of vane actuator technology. Unique cushion options are available for applications where control of high inertia loads is critical. The actuator incorporates load deceleration cushions which act over the last 20 to 25 degrees of rotation. These are field adjustable and can be selected to meet varying rotational speeds and loading.

### Tork-Mor Series

Tork-Mor Series actuators are produced in eighteen sizes generating up to 145,000 lb-in of torque at rated pressure. Capable of providing full torque instantly in either direction, they operate at pressures up to 1000 psi. The Tork-Mor Series can be mounted in any axis using a wide variety of standard or optional mountings.

Proven reliable through many years of field service, the Tork-Mor Series incorporates many quality features including precision ball bearings to provide shaft support, externally removable gland for ease of seal replacement and cylinders honed to a 10 micro inch finish to ensure long seal life.

#### SPECIFICATIONS

- **Nominal Pressure:** 1000 psi
- **Standard Rotations:** 90° to 270°
- **Output Torque @ 1000 psi:** 89 to 17,346 lb-in (10 to 1960 Nm)
- **Minimum Operating Pressure:** 145 psi



#### SPECIFICATIONS

- **Nominal Pressure:** 150-750 psi, depending on model
- **Standard Rotations:** S Models – 280° ± 1°; DS Models – 100° ± 1°
- **Output Torque @ 500 psi:** 800 to 142,000 lb-in
- **Maximum Allowable Drain Pressure:** 50 psi
- **Minimum Operating Pressure:** 25 psi





# LTR Series

Light Duty Hydraulic  
Rack & Pinion  
Rotary Actuators

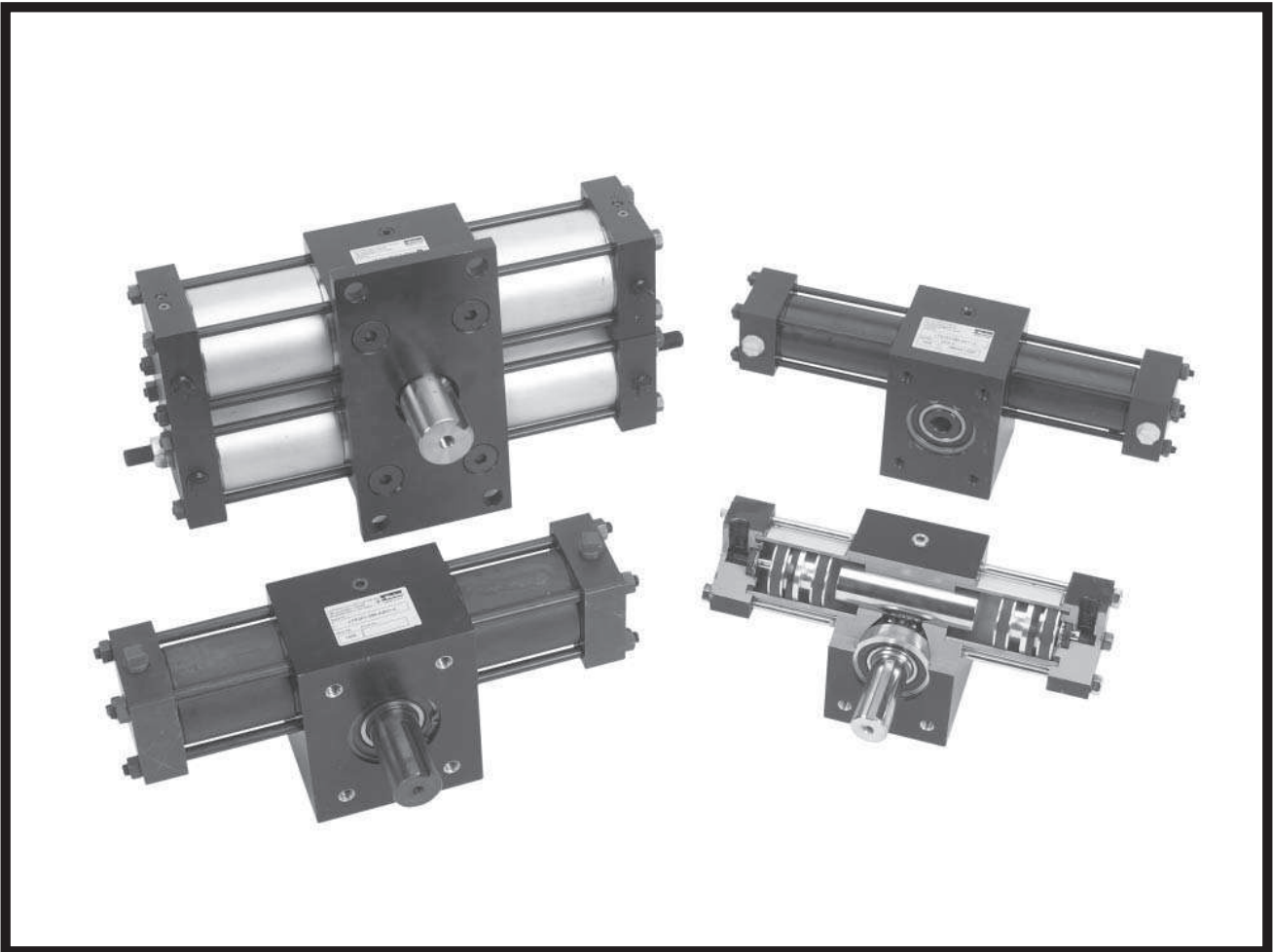

## Contents

Features .....	2
Ordering Information .....	3-4
Specifications .....	5
Engineering Data .....	6-8
Dimensional Data .....	9
Options	
Three-Position Actuator .....	10
Antibacklash Actuator .....	11
Port Threads, Port Location .....	12

## Options (cont)

Cushions .....	13
Stroke Adjusters .....	14
Port Flow Controls .....	14
Mounting .....	15
Shaft .....	16
Magnetic Piston .....	17
Shaft Seal Cover .....	17
Seals, Feedback .....	18
Proximity Sensors .....	19



**RACK & PINION** made from through hardened, high strength alloy steels for long and durable service life in most applications.

**HOUSING**  
High strength housing serves as a firm base to drive large torque requirements.

**OPTIONAL CUSHIONS**

If properly adjusted, cushions can serve as a braking device for most industrial applications. The proven Parker "floating cushion bushing" serves as a high performance check valve for "quick get away" and the needle valve can be adjusted to regulate the exhaust flow from the piston. Our design uses no springs or check valve seats that can break under normal usage.

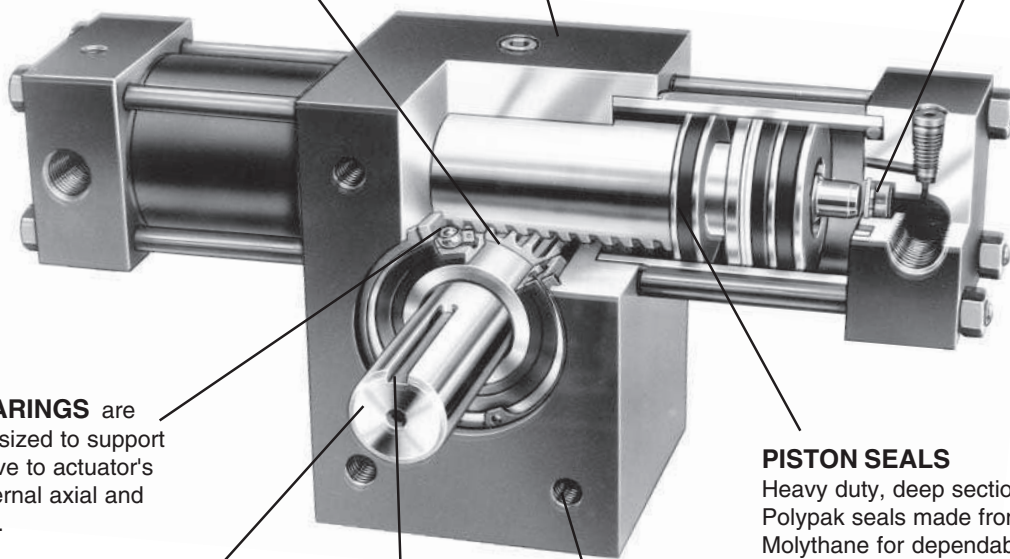

**BALL BEARINGS** are generously sized to support large (relative to actuator's weight) external axial and radial loads.

**STANDARD MALE KEYED SHAFT** is made integral with the pinion gear and is suitable for most applications. Options: double male key, hollow bore keyed and splined shafts are available.

**KEYWAY** mid stroke at 12:00 position is standard.

**PISTON SEALS**

Heavy duty, deep section Polypak seals made from Molythane for dependable service in most applications. Options: Fluorocarbon seals for certain synthetic fluids; and carboxylated nitrile seals for water based fluids. Piston seals can be inspected and replaced without disconnecting the load from the shaft. (Employ proper safety practices to prevent damage to people or equipment.)

**THREADED MOUNTING HOLES**

Our standard mounting has four bolt holes drilled and tapped on the front and back of the housing. Options: pilot ring or base mount.

Model Code & Ordering Information

Example: LTR251 - 0903FP - AB21M V - C

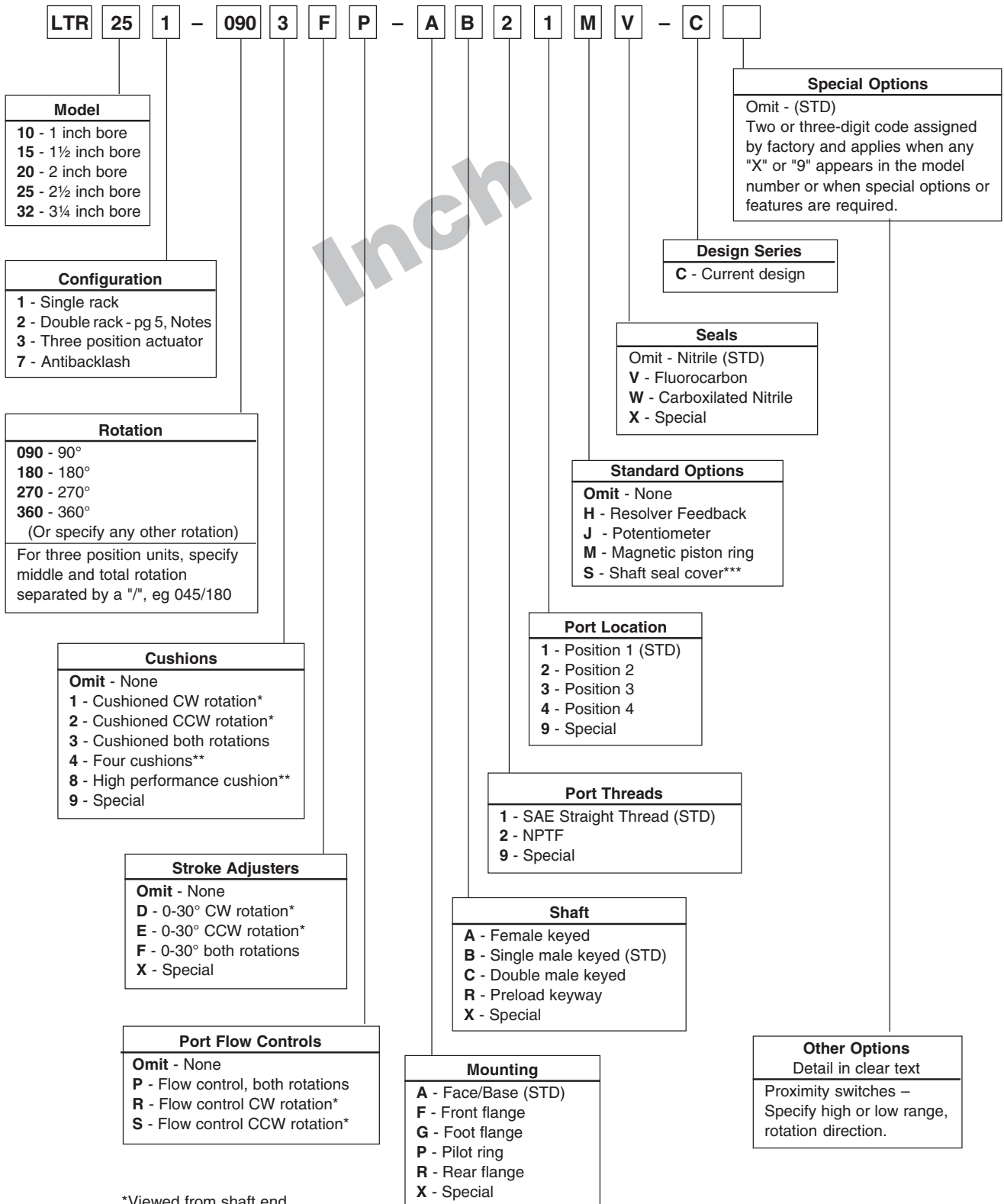

\*Viewed from shaft end  
 \*\*Double rack models only  
 \*\*\*For use with standard male shafts only

Model Code and Ordering Information

Example: LTR251 - 0903FP - BD41MV - C

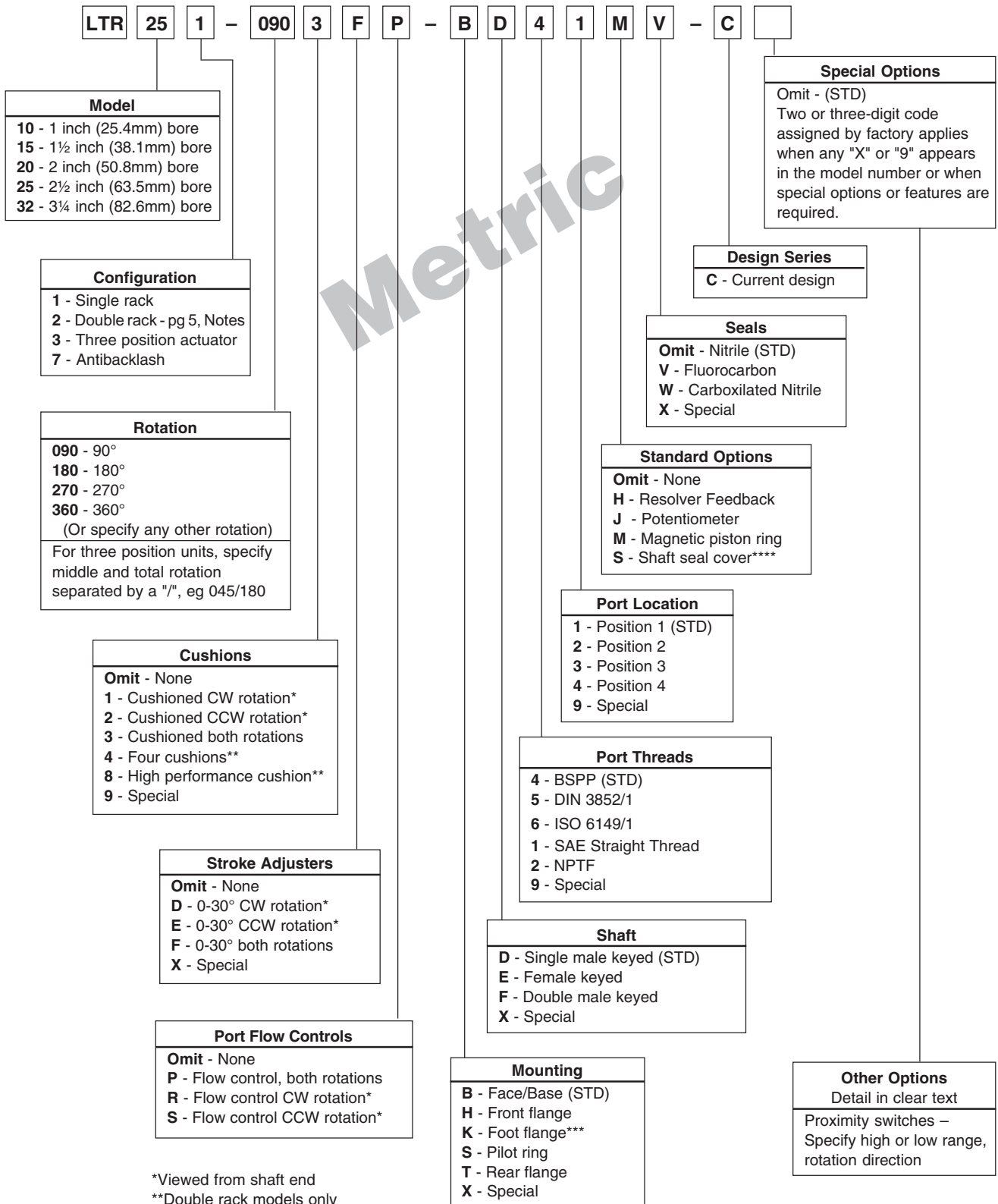

\*Viewed from shaft end  
\*\*Double rack models only  
\*\*\*Not available on Size 32  
\*\*\*\*For use with male shafts only



**LTR Series**

The LTR series actuator is suitable for low pressure hydraulic applications. The LTR Series actuator combines an alloy steel gear set with a high strength aluminum housing and Parker 3L or 2A Series cylinder components into a machine suitable for years of trouble free service. The actuator maximizes volumetric efficiency by using self-energizing PolyPak seals. Mechanical efficiency is maximized by using antifriction bearings and Wear-pak® piston technology.

The LTR actuator has a variety of options such as:

- Hydraulic cushions to minimize noise, vibration shock and assist deceleration control
- Reed, Hall Effect or proximity switches for position sensing
- End-of-rotation stroke adjusters for load position control and accurate rotation adjustment
- Built-in meter out flow control valves with reverse flow check valves provide a neat package
- Three position option can be used with many special machine and material handling applications

**SPECIFICATIONS**

- Standard rotations: 90°, 180°, 270°, 360°, 450°
- Maximum breakaway pressure: 30 psig (2 Bar)
- Mounting orientation: unrestricted
- Operating temperature range: Nitrile seals -40 to 180° F (-40 to 82°C)  
 Fluorocarbon seals -20 to 250°F (-29 to 121°C)
- Standard timing: Keyway in 12:00 position at midstroke
- Recommended filtration: ISO class 17/14 or better
- Nominal pressure: 1000 psig (68 Bar) (3L cylinder pressure ratings apply)

**Rack & Pinion Actuators**  
 LTR  
 HTR  
 M

Single Rack	Double Rack <sup>2</sup>	Theoretical Output Torque <sup>1</sup> , lb-in Versus Input Pressure, psi (Bar)						Gear Train Rating Pitting Life Estimate 1 million cycles		Displacement per degree of rotation in <sup>3</sup> /deg.	Maximum angular backlash Minutes	Maximum rotational tolerance Degrees
		100 (7)	250 (17)	500 (34)	750 (52)	1000 (69)	1500 (103)	lbf-inch <sup>3</sup>	PSID <sup>4</sup>			
101		39	98	197	295	395	592	270	800	0.007	60	-0/+5
	102	79	197	395	592	-	-	580	800	0.014	60	-0/+5
151		118	294	590	885	1180	1770	665	650	0.021	45	-0/+4
	152	236	590	1180	1770	2360	3530	1400	650	0.042	45	-0/+4
201		282	705	1410	2115	2830	4240	1790	750	0.049	35	-0/+3
251		430	1074	2148	3222	4295	6443	2100	550	0.075	35	-0/+3
	202	565	1410	2820	4230	5650	8470	3790	750	0.099	35	-0/+3
	252	859	2148	4295	6442	8590	12885	4250	550	0.150	35	-0/+3
321		1141	2852	5703	8554	11407	-	3880	400	0.199	25	-0/+2
	322	2281	5703	11407	17110	22813	-	6160	300	0.398	25	-0/+2

**NOTES:**

1. As a precaution, consult factory whenever using the LTR with port flow controls, cushions, or stroke adjusters on double rack units. These options may require the units to be pressure derated.
2. Double rack actuators should specify type 4 or 8 cushions and four stroke adjusters and four flow controls (one per end cap) to balance the gear tooth forces on the pinion. Contact the factory for ordering code information. Type 1, 2, or 3 cushions, type A, B, or C stroke adjusters and type P, R, and S port flow controls may cause a destructive bending couple upon the pinion gear under some operating conditions.
3. Durability rated output torque.
4. Pressure differential between the inlet and outlet ports (non-shock).
5. Reduce LTR Series pressure rating by 50% when specifying a magnetic piston with aluminum cylinder tubes, option "M" except on LTR101 and 102 models.

### Bearing Load Capacities & Gear Train Available

Model	Bearing Load Capacities*				Distance		Available Stopping Work per Endcap / Cushion**			
	Radial		Thrust		Between Bearings		Strength Criteria		Durability Criteria	
	lb	kN	lb	kN	inch	mm	in-lb	Nm	in-lb	Nm
10	100	0.4	50	0.2	1.40	35	300	34	141	16
15	250	1.1	125	0.5	2.15	54	900	102	348	39
20	500	2.2	250	1.1	2.15	54	1500	169	936	106
25	750	3.3	375	1.6	2.50	63	2250	254	1098	124
32	1000	4.4	500	2.2	3.75	95	5000	565	2029	229

\* Bearing capacities only.

\*\* Check total stopping torque ratings to determine if actuator will stop load. Double rack actuators should use Type 4 or Type 8 cushion option for table data to remain correct.

### Cushion Deceleration Control

The cushion causes the resisting torque that can be used to decelerate a rotational load. Please note the cushion has to provide enough resistance to control: drive torque caused by the hydraulic system pressure; plus the torque caused by gravity pulling on the rotational load; and the kinetic energy associated with the motion of the inertia load. Since the actuator's cushion has to be able to control the sum of all three torque factors, we suggest including cushion capacity as one of the actuator selection criteria.

It is strongly suggested that proportional valves be used instead of cushions to control (decelerate) high inertial loads. This provides the ability to reduce inlet pressure while generating deceleration pressure. It also allows for longer ramp times, thus increasing deceleration stroke.

#### SUPPLEMENTAL INFORMATION KINETIC ENERGY BASIC FORMULA

$$KE = 1/2 J_m \omega^2$$

$$\omega = 0.0175 \times \frac{2\Theta_A + \Theta_C + 2\Theta_D}{\text{Rotation Time (sec.)}}$$

where:

KE = Kinetic Energy (in-lb)

$J_m$  = Rotational Mass Moment of Inertia (in-lb-sec<sup>2</sup>)

See Page 8 for formulas.

$\omega$  = Peak Velocity (rad/sec)

(Assuming trapezoidal velocity profile)

$\Theta_A$  = Acceleration Angle (deg)

$\Theta_C$  = Constant Velocity Angle (deg)

$\Theta_D$  = Deceleration Angle (deg)

### Kinetic Energy Capacity

The energy values below assume drive pressure is maintained through cushion stroke.

#### Single Rack Units with Single Set of Cushions (30°)

Model	Kinetic Energy Rating(in-lb) of Cushion at Specified Drive Pressure*											
	0 psi		250 psi		500 psi		750 psi		1000 psi		1500 psi	
	Max.	Durability	Max.	Durability	Max.	Durability	Max.	Durability	Max.	Durability	Max.	Durability
LTR101	310	141	258	141	207	141	155	141	103	103	0	0
LTR151	927	348	772	348	618	348	463	348	309	309	0	0
LTR201	2220	936	1850	936	1480	936	1110	936	740	740	0	0
LTR251	3373	1098	2811	1098	2248	1098	1686	1098	1124	1098	0	0
LTR321	11945	2029	8959	2029	5973	2029	2986	2029	0	0	na	na

#### Double Rack Units with Single Set of Cushions (30°)

Model	Kinetic Energy Rating(in-lb) of Cushion at Specified Drive Pressure*											
	0 psi		250 psi		500 psi		750 psi		1000 psi		1500 psi	
	Max.	Durability	Max.	Durability	Max.	Durability	Max.	Durability	Max.	Durability	Max.	Durability
LTR102	310	141	103	103	0	0	0	0	0	0	0	0
LTR152	924	348	616	348	308	308	0	0	0	0	0	0
LTR202	2217	936	1478	936	739	739	0	0	0	0	0	0
LTR252	3373	1098	2249	1098	1124	1098	0	0	0	0	0	0
LTR322	5971	2029	2986	2029	0	0	0	0	0	0	0	0

#### Double Rack Units with Double Set of Cushions (30°)\*\*

Model	Kinetic Energy Rating(in-lb) of Cushion at Specified Drive Pressure*											
	0 psi		250 psi		500 psi		750 psi		1000 psi		1500 psi	
	Max.	Durability	Max.	Durability	Max.	Durability	Max.	Durability	Max.	Durability	Max.	Durability
LTR102	310	303	206	206	103	103	0	0	0	0	0	0
LTR152	1848	732	1540	732	1232	732	924	732	616	616	0	0
LTR202	4434	1982	3695	1982	2956	1982	2217	1982	1478	1478	0	0
LTR252	6745	2223	5621	2223	4496	2223	3373	2223	2248	2223	0	0
LTR322	11943	3222	8957	3222	5971	3222	2986	2986	0	0	0	0

\* Must deduct work (energy) done to overcome potential energy effects of load.  $W_{PE} = T_{PE} \times \theta$ , where  $\theta$  is in radians.

\*\* Extreme care must be exercised so that both cushions are adjusted equally for each direction or dangerous pressure intensification and gear train stresses could result. (Suggest high performance cushion option.)

### Unit Weights

Model	Rotation							
	90°		180°		270°		360°	
	lb	kg	lb	kg	lb	kg	lb	kg
LTR101	2 <sup>1</sup> / <sub>4</sub>	1	2 <sup>1</sup> / <sub>2</sub>	1.1	2 <sup>3</sup> / <sub>4</sub>	1.2	3	1.3
LTR102	3 <sup>1</sup> / <sub>2</sub>	1.6	3 <sup>7</sup> / <sub>8</sub>	1.8	4 <sup>1</sup> / <sub>4</sub>	1.7	4 <sup>5</sup> / <sub>8</sub>	2.1
LTR151	8 <sup>7</sup> / <sub>8</sub>	4	9 <sup>5</sup> / <sub>8</sub>	4.3	10 <sup>3</sup> / <sub>8</sub>	4.7	11 <sup>1</sup> / <sub>8</sub>	5
LTR152	12 <sup>5</sup> / <sub>8</sub>	5.7	14 <sup>1</sup> / <sub>8</sub>	6.4	15 <sup>5</sup> / <sub>8</sub>	7.1	19 <sup>1</sup> / <sub>2</sub>	8.8
LTR201	14 <sup>5</sup> / <sub>8</sub>	6.6	16	7.2	17 <sup>3</sup> / <sub>8</sub>	7.9	18 <sup>7</sup> / <sub>8</sub>	8.6
LTR202	21 <sup>3</sup> / <sub>4</sub>	9.9	24 <sup>1</sup> / <sub>2</sub>	11.1	27 <sup>1</sup> / <sub>2</sub>	12.5	30 <sup>1</sup> / <sub>2</sub>	13.8
LTR251	22 <sup>5</sup> / <sub>8</sub>	10.3	24 <sup>3</sup> / <sub>4</sub>	11.2	27 <sup>1</sup> / <sub>4</sub>	12.4	29 <sup>3</sup> / <sub>8</sub>	13.3
LTR252	33 <sup>5</sup> / <sub>8</sub>	15.2	38 <sup>1</sup> / <sub>8</sub>	16.8	42 <sup>3</sup> / <sub>4</sub>	19.4	47 <sup>1</sup> / <sub>8</sub>	21.4
LTR321	46 <sup>5</sup> / <sub>8</sub>	21.1	50 <sup>1</sup> / <sub>8</sub>	22.7	53 <sup>1</sup> / <sub>2</sub>	24.3	56 <sup>7</sup> / <sub>8</sub>	25.8
LTR322	66 <sup>5</sup> / <sub>8</sub>	30.2	73 <sup>5</sup> / <sub>8</sub>	33.4	78 <sup>3</sup> / <sub>8</sub>	35.5	87 <sup>1</sup> / <sub>8</sub>	39.5

1800\_LTR.pmd, M&A



Rack & Pinion Actuators  
LTR  
HTR  
M

**Kinetic Energy Basic Formula**

$$KE = 1/2 J_m \omega^2$$

$$\omega = 0.0175 \times \frac{2\Theta_A + \Theta_C + 2\Theta_D}{\text{Rotation Time (Sec.)}}$$

where:

KE = Kinetic Energy (in-lb)

$J_m$  = Rotational mass moment of inertia (in-lb-sec<sup>2</sup>)

(Dependent on physical size of object and weight)

$\omega$  = Peak Velocity (rad/sec) (Assuming trapezoidal velocity profile)

$\Theta_A$  = Acceleration Angle (deg)

$\Theta_C$  = Constant Velocity Angle (deg)

$\Theta_D$  = Deceleration Angle (deg)

W = Weight of load (lb)

g = Gravitational constant = 386.4 in/sec<sup>2</sup>

k = Radius of gyration (in)

**MASS MOMENTS OF INERTIA  
 MODELS & FORMULAS**

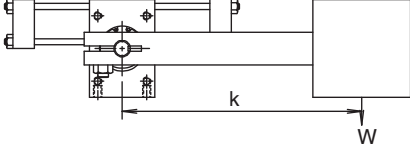
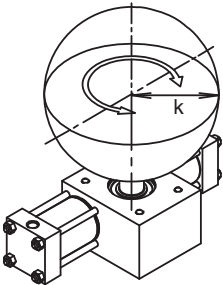
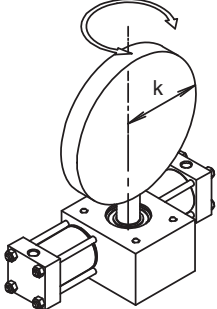
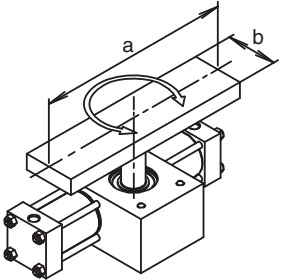
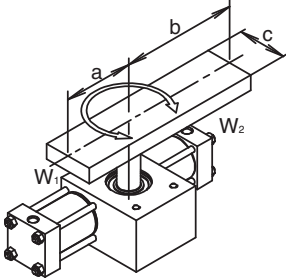
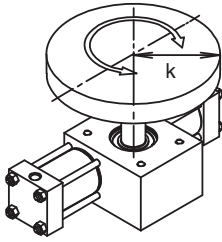
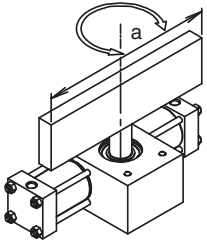
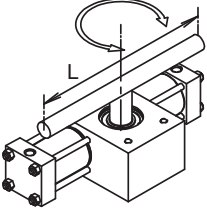
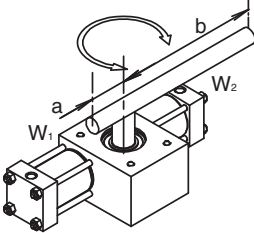
<p><b>POINT LOAD</b></p>  $J_m = \frac{W}{g} \times k^2$	<p><b>SOLID SPHERE -                  Mounted on center</b></p>  $J_m = \frac{2}{5} \times \frac{W}{g} \times k^2$	<p><b>THIN DISK-                  End mounted on center</b></p>  $J_m = \frac{W}{g} \times \frac{k^2}{4}$
<p><b>THIN RECTANGULAR PLATE                  Mounted on center</b></p>  $J_m = \frac{W}{g} \times \frac{a^2 + b^2}{12}$	<p><b>THIN RECTANGULAR PLATE                  Mounted off center</b></p>  $J_m = \frac{W_1}{g} \times \frac{4a^2 + c^2}{12} + \frac{W_2}{g} \times \frac{4b^2 + c^2}{12}$	<p><b>THIN DISK                  Mounted on center</b></p>  $J_m = \frac{W}{g} \times \frac{k^2}{2}$
<p><b>THIN RECTANGULAR PLATE                  End mounted on center</b></p>  $J_m = \frac{W}{g} \times \frac{a^2}{12}$	<p><b>SLENDER ROD                  Mounted on center</b></p>  $J_m = \frac{W}{g} \times \frac{L^2}{12}$	<p><b>SLENDER ROD                  Mounted off center</b></p>  $J_m = \frac{W_1}{g} \times \frac{a^2}{3} + \frac{W_2}{g} \times \frac{b^2}{3}$

1800\_LTR.pmd, M&A

**Standard Inch Unit with Face/Base Mount (A) and Male Keyed Shaft (B)**  
**Standard Metric Unit with Face/Base Mount (B) and Male Keyed Shaft (D)**

Double Male Keyed Shaft (C, F) shown in phantom

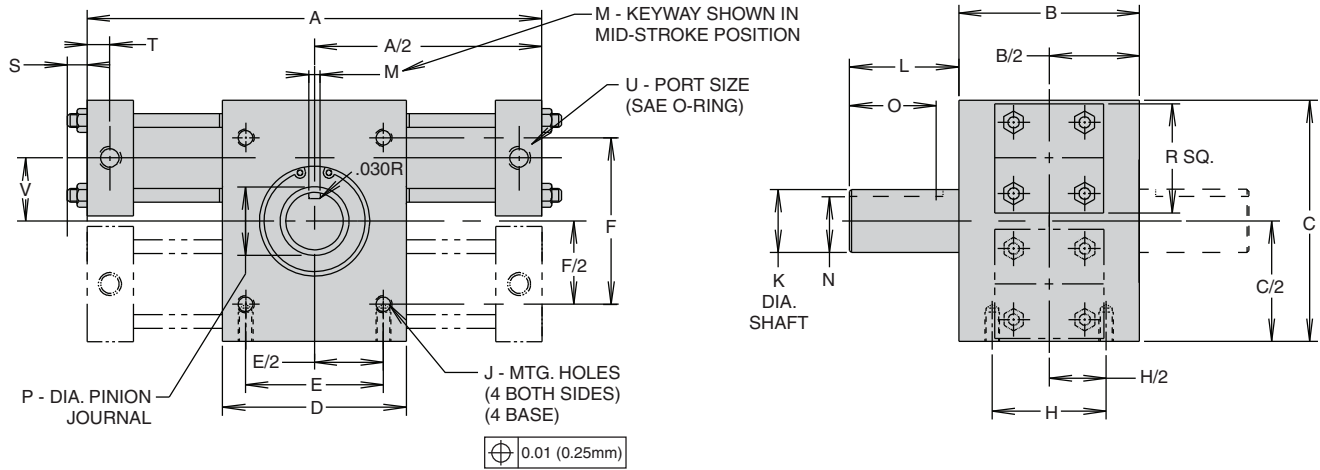

**Rack & Pinion Actuators**  
 LTR  
 HTR  
 M

**Dimensions for Inch Unit (inches)**

Model	Rotation	A	B	C	D	E	F	H	J	K	L	M	N	O	P	R	S	T	U	V
10	90°	6 <sup>11</sup> / <sub>16</sub>							1/4-20	.500		.125	.430						7/16-20	
	180°	8 <sup>1</sup> / <sub>4</sub>	2	3	2	1.50	2.00	1.50	x 3/8	.499	7/8	.127	.425	5/8	.59	1 <sup>1</sup> / <sub>2</sub>	1/4	.31	SAE #4	3/4
	360°	11 <sup>7</sup> / <sub>16</sub>							DP											
15	90°	9 <sup>1</sup> / <sub>8</sub>							5/16-18	.875		.188	.771						7/16-20	
	180°	11 <sup>3</sup> / <sub>16</sub>	3	4 1/4	3	2.00	3.00	2.00	x 1/2	.874	1 <sup>7</sup> / <sub>8</sub>	.190	.761	1 <sup>1</sup> / <sub>2</sub>	.98	2	5/16	.44	SAE#4	1 <sup>1</sup> / <sub>16</sub>
	360°	15 <sup>3</sup> / <sub>8</sub>							DP											
20	90°	11 <sup>3</sup> / <sub>16</sub>							3/8-16	1.125		.250	.986						9/16-18	
	180°	14 <sup>1</sup> / <sub>16</sub>	3	5	4	2.50	3.50	2.00	x 1/2	1.124	1 <sup>7</sup> / <sub>8</sub>	.252	.976	1 <sup>1</sup> / <sub>2</sub>	1.18	2 <sup>1</sup> / <sub>2</sub>	3/8	.44	SAE #6	1 <sup>1</sup> / <sub>4</sub>
	360°	19 <sup>1</sup> / <sub>16</sub>							DP											
25	90°	12 <sup>9</sup> / <sub>16</sub>							1/2-13	1.375		.313	1.201						9/16-18	
	180°	15 <sup>1</sup> / <sub>2</sub>	3 <sup>1</sup> / <sub>2</sub>	6	4	2.50	4.50	2.00	x 3/4	1.374	2 <sup>1</sup> / <sub>4</sub>	.315	1.191	1 <sup>3</sup> / <sub>4</sub>	1.38	3	3/8	.44	SAE #6	1 <sup>1</sup> / <sub>2</sub>
	360°	20 <sup>5</sup> / <sub>8</sub>							DP											
32	90°	16 <sup>5</sup> / <sub>8</sub>							3/4-10	1.750		.375	1.542						3/4-16	
	180°	21 <sup>1</sup> / <sub>8</sub>	5	8	5	3.00	5.00	2.50	x 1	1.749	3 <sup>1</sup> / <sub>2</sub>	.377	1.532	3	1.77	3 <sup>3</sup> / <sub>4</sub>	7/16	.56	SAE #8	1 <sup>15</sup> / <sub>16</sub>
	360°	29 <sup>3</sup> / <sub>8</sub>							DP											

**Dimensions for Metric Unit (mm)**

Model	Rotation	A	B	C	D	E	F	H	J	K	L	M <sub>P9</sub>	N	O	P	R	S	T	U*	V
10	90°	169.9							M6	12.00		4	10.9							
	180°	209.6	50.8	76.2	50.8	40	50	40	x 1	11.98	22.2		10.8	15	15	38.1	6.4	7.9	1/8	19.1
	360°	290.5							x 10 DP											
15	90°	231.8							M8	22.00		6	18.5							
	180°	284.2	76.2	108.0	76.2	50	80	50	x 1.25	21.98	47.6		18.4	38	25	50.8	7.9	11.2	1/4	27.0
	360°	390.5							x 13 DP											
20	90°	284.2							M10	28.00		8	24.0							
	180°	357.2	76.2	127.0	101.6	63	90	50	x 1.5	27.98	47.6		23.8	38	30	63.5	9.5	11.2	1/4	31.8
	360°	500.1							x 13 DP											
25	90°	319.1							M12	34.00		10	29.0							
	180°	393.7	88.9	152.4	101.6	63	115	50	x 1.75	33.98	57.2		28.8	44	35	76.2	9.5	11.2	1/4	38.1
	360°	523.9							x 19 DP											
32	90°	422.3							M20	42.00		12	37.0							
	180°	536.6	127.0	203.2	127.0	80	125	63	x 2.5	41.98	88.9		36.8	76	45	95.3	11.1	14.2	1/2	49.2
	360°	746.1							x 25 DP											

\* BSPP/G  
 1800\_LTR.pmd, M&A



### Three Position Actuator (3)

In addition to the standard two position actuators, three position units are also available. All standard options are also available.

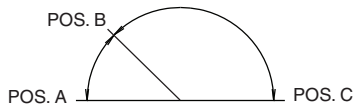

#### OPERATION:

A standard double rack unit is fitted with stop tubes of varying lengths on the upper rack. Pressurizing port C-2 (with ports C-1, C-3 exhausted) causes counterclockwise pinion rotation to angular position A. Alternately applying pressure to C-1 (with C-2 and C-4 exhausted) will cause clockwise rotation to angular position C. Both positions A and C are at end of stroke, thus typical end cap options such as cushions, bumpers, and stroke adjusters will operate at these positions only.

Position B is obtained by pressurizing all ports. Pressure applied to the upper floating pistons centers the rack between the stop tubes, rotating the pinion to position B. The lower rack is free floating as the forces are equal on both ends.

#### DIMENSIONAL DATA:

Three position actuator dimensions are identical to the standard double rack units. If stroke adjusters are specified they will be fitted to the upper rack, flow controls and cushions will be on the lower rack. Rotational tolerances are given in the chart at the right.

#### OUTPUT TORQUE:

Output torque of the multiple position actuator is equivalent to the torque output of the same size single rack unit. The chart to the right gives selected torque values for specified pressures.

#### ORDERING INFORMATION:

Three position actuators can be ordered by inserting a 3 into the "configuration" space in the model code. The desired middle and total rotation should be stated in the model code separated by a "/". The beginning position, 0°, need not be specified. For example: **LTR153-045/180-AB21-C** is a standard, three position actuator. Position A is 0°, position B is 45°, and position C is 180°.

**CAUTION:** Keep loop pressure drops low for proper operation.

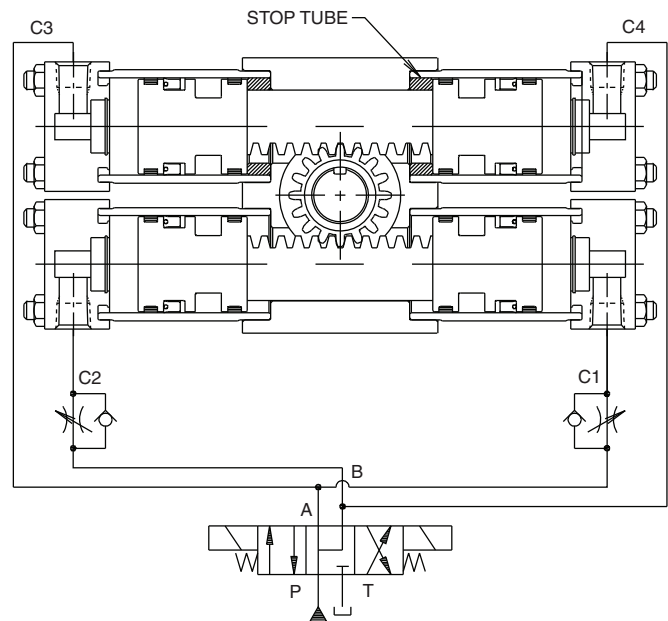

Rotation Tolerances			
Model	Total Rotation, Degrees	Between Positions, Degrees <sup>1</sup>	Backlash Minutes <sup>2</sup>
103	-0, +5	±1	50
153	-0, +4	±1/2	40
203	-0, +3	±1/2	30
253	-0, +3	±1/2	30
323	-0, +2	±1/4	15

1. Measured from centers of backlash.
2. Zero backlash can be achieved at positions A and C by using optional stroke adjusters.

Theoretical Output Torque, (lb-in) at Specified Pressure			
Model	100 psi (6.8 Bar)	500psi (34 Bar)	1000 psi (68 Bar)
103	39	197	395
153	118	590	1180
203	282	1410	2820
253	430	2148	4295
323	1141	5703	11407

**NOTE:** When magnetic piston ring option "M" is ordered, all pistons will be so equipped. The pressure rating is derated by 50% with magnetic piston option.

### Antibacklash Actuator (7)

An antibacklash actuator is used to obtain precision positioning at the end of rotation. The backlash normally associated with rack and pinion actuators is eliminated by this unique configuration.

#### OPERATION:

A double rack unit is modified for actuation on one end only. Alternately pressurizing C-1 or C-2 causes clockwise and counter-clockwise rotation, respectively. Backlash in the rack & pinion is eliminated as the pinion is tightly "trapped" between both racks at the end of stroke, preventing any further motion.

#### DIMENSIONAL DATA:

Antibacklash actuators are similar in size and configuration to standard double rack units with one set of shorter cylinders. The table to the right shows dimensions for this shorter side. If cushions, stroke adjusters or port flow controls are ordered, they will be fitted to the powered rack side.

#### OUTPUT TORQUE:

Output torque of the antibacklash actuator is equivalent to the torque output of the same size single rack unit. The chart to the right gives selected torque values for specified pressures.

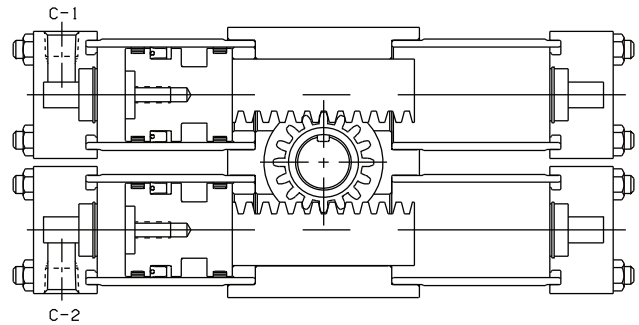
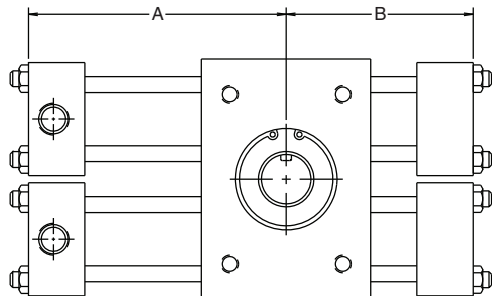

Model	Rotation	A		B	
		Inch	mm	Inch	mm
107	90	3 <sup>3</sup> / <sub>4</sub>	95	2 <sup>3</sup> / <sub>4</sub>	70
	180	4 <sup>1</sup> / <sub>8</sub>	105	3 <sup>3</sup> / <sub>4</sub>	95
	360	5 <sup>3</sup> / <sub>4</sub>	146	5	127
157	90	4 <sup>9</sup> / <sub>16</sub>	116	3 <sup>5</sup> / <sub>16</sub>	84
	180	5 <sup>5</sup> / <sub>8</sub>	143	4 <sup>9</sup> / <sub>16</sub>	116
	360	7 <sup>11</sup> / <sub>16</sub>	195	6 <sup>5</sup> / <sub>8</sub>	168
207	90	5 <sup>5</sup> / <sub>8</sub>	143	4 <sup>1</sup> / <sub>8</sub>	105
	180	7 <sup>1</sup> / <sub>16</sub>	179	5 <sup>5</sup> / <sub>8</sub>	143
	360	9 <sup>7</sup> / <sub>8</sub>	251	8 <sup>1</sup> / <sub>2</sub>	216
257	90	6 <sup>5</sup> / <sub>16</sub>	160	4 <sup>-3</sup> / <sub>8</sub>	111
	180	7 <sup>3</sup> / <sub>4</sub>	197	6 <sup>-5</sup> / <sub>16</sub>	160
	360	10 <sup>5</sup> / <sub>16</sub>	262	8 <sup>-13</sup> / <sub>16</sub>	224
327	90	8 <sup>5</sup> / <sub>16</sub>	211	5 <sup>-13</sup> / <sub>16</sub>	148
	180	10 <sup>9</sup> / <sub>16</sub>	268	8 <sup>-5</sup> / <sub>16</sub>	211
	360	14 <sup>11</sup> / <sub>16</sub>	373	12 <sup>-7</sup> / <sub>16</sub>	316

Theoretical Output Torque, (lb-in) at Specified Pressure			
Model	100 psi (6.8 Bar)	500psi (34 Bar)	1000 psi (68 Bar)
107	39	197	395
157	118	590	1180
207	282	1410	2820
257	430	2148	4295
327	1141	5703	11407

#### ORDERING INFORMATION:

Antibacklash actuators can be ordered by inserting a "7" into the "configuration" space in the model code. For example: **LTR157-180F-AR21-C** is a hydraulic antibacklash actuator with a theoretical output torque of 1000 lb-in at 1000 psi.

The optional stroke adjusters make the rotation variable between 120° and 180°. The preload key option on the shaft is also specified to eliminate any backlash in the key and flange coupling interface.

**Port Location (1, 2, 3, 4, 5)**

End caps can be assembled to the units with ports facing different directions as shown.

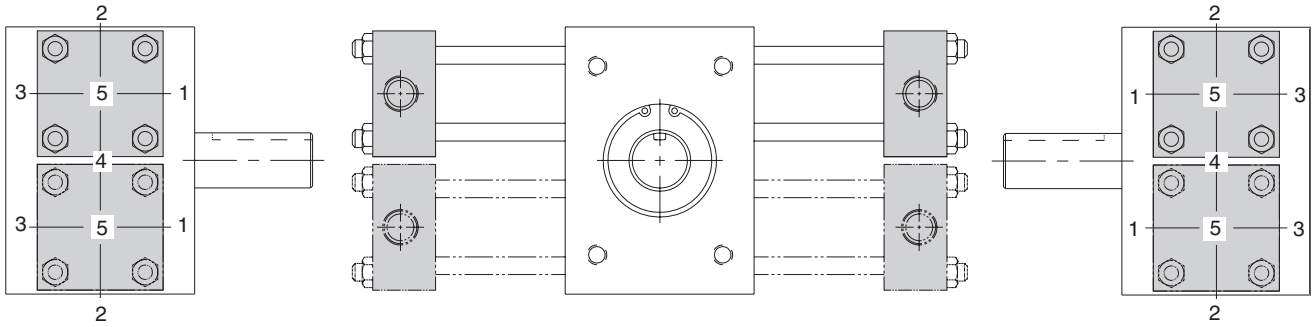

- NOTE:**
1. Port position 1 is standard.
  2. Port positions 2, 3 and 4 are standard options available at no additional cost.
  3. Port position 4 available with single rack actuators only.
  4. For port position 5, consult factory.

**Port Threads (1, 2, 4, 5, 6)**

Model	Standard SAE Straight Thread (1)	NPT (2)	BSPP/G (4)	Metric DIN (5) & ISO (6)
10	7/16 - 20 (SAE 4)	1/8	1/8	M10 x 1
15	7/16 - 20 (SAE 4)	1/4	1/4	M14 x 1.5
20	9/16 - 18 (SAE 6)	1/4	1/4	M14 x 1.5
25	9/16 - 18 (SAE 6)	1/4	1/4	M14 x 1.5
32	3/4 - 16 (SAE 8)	3/8	1/2	M22 x 1.5

**ISO 6149/1 Port Identification**

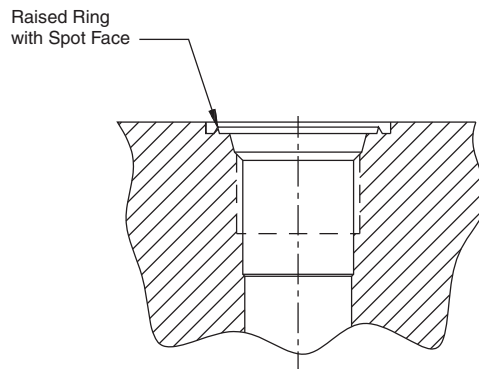



### Cushions (1, 2, 3, 4) \*

The standard cushions operate over the last 30° of rotation in either CW, CCW or both directions. A floating bushing ensures no binding of the cushion spear. For severe operating conditions, four cushions should be fitted on double rack units. All cushions are fully adjustable. On double rack units with type 1, 2 or 3, cushion adjustment will be located on the upper cylinder.

STANDARD CUSHION ADJUSTER NEEDLE LOCATIONS

Port Position	Cushion Adjuster Position
1	2
2	3
3	2
4**	3
5	Consult Factory

\*\*On single rack only

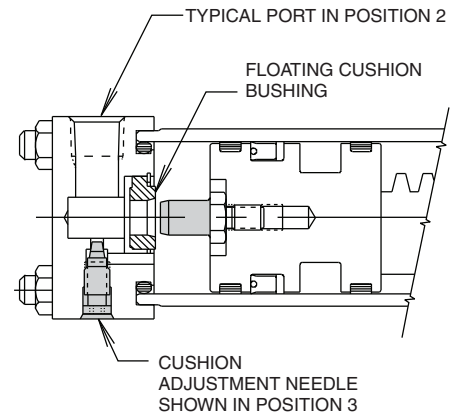

\* For gear train durability, see table below.

### High Performance Cushion (8)

(This option available with double rack units only)

By combining the output/exhaust flow from two cylinders, then routing it across a single cushion needle, cushion performance is improved. The increased volume passing over the needle provides better control. This unique circuit eliminates two pipe or tubing tees.

#### OPERATION:

The work ports of a standard directional valve are plumbed to ports C-1 and C-2. Port A-1 is plumbed directly to A-2, and port B-1 is plumbed to B-2. When pressure is applied to port C-1 (clockwise shaft rotation), fluid is also directed through line A to the other rack. Exhaust flow from B-1 through B-2 is directed through the cushion bushing and cushion adjustment. When the cushion spear closes off the main passage, total flow from both end caps is directed across one cushion adjustment needle, equalizing back pressure and improving control. Alternatively, pressurizing C-2 and exhausting C-1 reverses the operation.

#### DIMENSIONAL INFORMATION:

Units are identical to standard double rack and pinion units, with the exception of porting location. This chart describes the location of the ports.

**Suggestion:** Use Type 4 or Type 8 cushion arrangements for double rack actuators. Use Type 1, 2 or 3 cushion arrangements exclusively for single rack actuators.

#### GEAR SET DURABILITY

The table to the right provides energy ratings based on gear train durability when using various cushion options for the LTR Series.

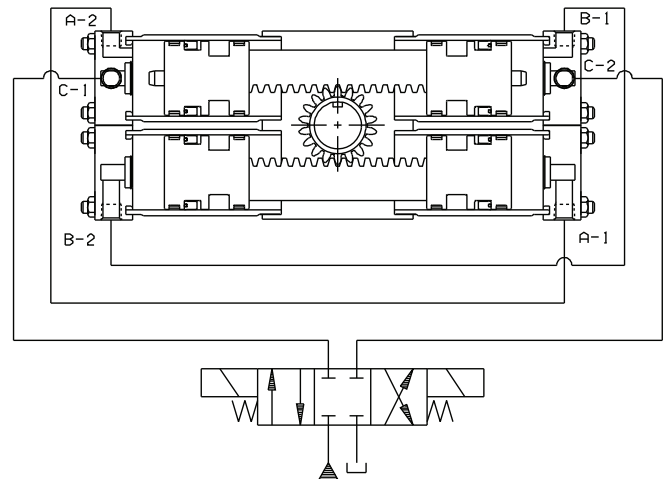

Work Ports C-1, C-2 Port Position	Cushion Adjustment Position	Connection Ports A-1, A-2 & B-1, B-2 Port Position
1	2	3
2	3	1
3	2	1

Model	Total Energy Capacity (in-lb)		Port to Port ΔP (PSID)	
	Code 1,2,3	Code 8	Code 1,2,3	Code 8
LTR101	141	N/A	800	N/A
LTR102	141	303	400	800
LTR151	348	N/A	650	N/A
LTR152	348	732	325	650
LTR201	936	N/A	750	N/A
LTR202	936	1982	375	750
LTR251	1098	N/A	550	N/A
LTR252	1098	2223	275	550
LTR321	2029	N/A	400	N/A
LTR322	2029	3222	200	400

### Stroke Adjusters (D, E, F) 30°

Fine control of the end of travel points of the rotary actuator can be obtained by specifying stroke adjusters. These operate by reducing the maximum travel of the actuator by up to 30° in each rotational direction. Adjustment within this range is made by the user. Several types of stroke adjuster are available. The design illustrated is suitable for applications requiring infrequent adjustment.

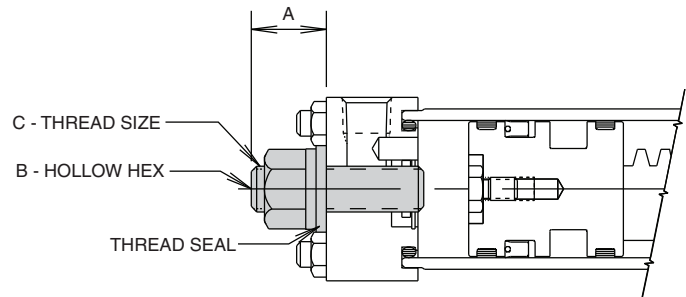

### Stroke Adjusters and Cushions

The addition of stroke adjusters requires an increase in build length. On double rack units with cushions, the cushion is fitted to the upper rack and the stroke adjuster to the lower unless otherwise specified. (Consult factory.)

The increase in build length, for both single and double rack units, is shown as dimension A in the table. Cushion performance may be affected by the addition of a stroke adjuster. Please consult the factory in critical applications.

Model	One (1) Turn Adj.	A (max) –Increased Build Length				B	C UNF
		30°Adjustment without Cushioned End Cap		10°Adjustment* with Cushioned End Cap			
		Inch	mm	Inch	mm		
10	4.0°	.63	16	.38	10	1/8	1/4-28
15	4.2°	.88	23	1.13	29	1/4	1/2-20
20	3.1°	1.13	29	1.13	29	1/4	1/2-20
25	3.3°	1.13	29	1.13	29	1/4	1/2-20
32	2.6°	1.50	38	2.13	54	3/8	3/4-16

\* Standard cushions operate over the last 30° of standard rotation. Stroke adjuster will decrease the effective cushion length by the amount of inward adjustment.

**CAUTION:** Due to end of stroke loading on some applications, four stroke adjusters may be needed with double rack actuators to avoid pinion gear damage.

### Port Flow Controls (P, R, S)

Built in meter-out flow controls provide adjustment of actuator speed and eliminate the cost and space needed for externally plumbed components. A separate ball check is used to provide free flow in the opposite direction. Flow controls may be ordered in conjunction with cushions or stroke adjusters.

Four port flow controls are suggested with double rack actuators to avoid pinion gear damage.

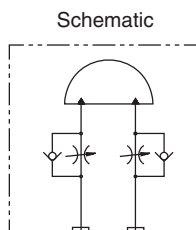
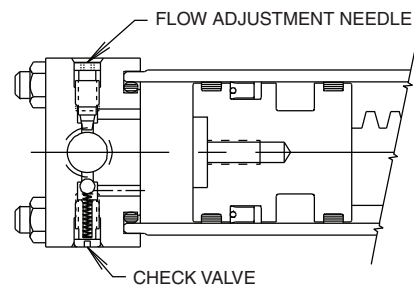

### STANDARD ADJUSTMENT NEEDLE LOCATIONS

Port Position	Needle Position
1	2
2	3
3	2
4*	3

\*On single rack only

**NOTE:** When both cushions and port flow controls are specified the end caps will be stamped "C" and "P" respectively near the adjustment needles.

**Mounting Options:**

**Inch Units (F, G, P, R)**

**Metric Units (H, K, S, T)**

**Flanged and Pilot Mountings**

LTR Series rotary actuators are available with options such as face/base, pilot or flanged mounting styles to suit the requirements of different applications.

**Note:** Actuators are shipped with mounting flange installed unless otherwise noted.

**Foot Flange (G, K)**

Model	Inch (G)						Metric (K)					
	A	B	C	D	E	F	A	B	C	D	E	F
10	3.25	2.00	2.625	1.375	.250	.281	82	51	67	35	7	6.5
15	4.50	3.00	3.875	2.125	.438	.406	114	76	98	54	11	11
20	4.50	4.00	3.875	3.375	.438	.406	114	102	98	86	11	11
25	5.50	4.00	4.500	3.000	.438	.531	140	102	114	76	11	13.5
32	8.00	5.00	6.500	3.500	.750	.781	N/A	N/A	N/A	N/A	N/A	N/A

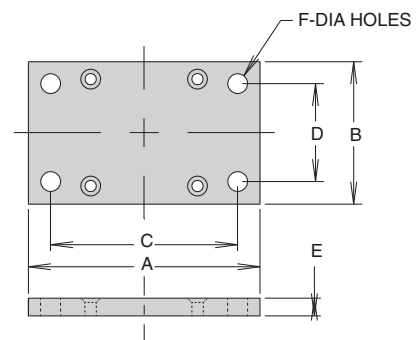

**Pilot Ring (P, S)**

Model	Inch (P)		Metric (S)	
	G	H	G	H
10	1.124	.125	28.55	3.2
15	2.000	.25	50.80	6.4
20	2.166	.25	55.01	6.4
25	2.680	.25	68.07	6.4
32	3.347	.25	85.01	6.4

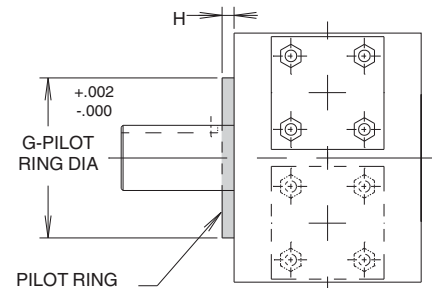

**Front (F, H) or Rear Flange (R, T)**

**NOTE:** Shaft seal cover option "S" is not available with flange mounting.

Model	Inch (F, R)							Metric (H, T)						
	J	K	L	M	N	P	Q	J	K	L	M	N	P	Q
10	4.25	2.00	3.625	1.375	.250	.281	.625	108	51	92	35	7	6.5	15
15	5.75	3.00	5.125	2.125	.438	.406	1.000	146	76	130	54	11	11	25
20	6.50	4.00	5.875	3.375	.438	.406	1.250	165	102	149	86	11	11	31
25	8.25	4.00	7.250	3.000	.438	.531	1.625	210	102	184	76	11	13.5	40
32	12.00	5.00	10.000	3.000	.750	.781	2.000	305	127	254	76	19	22	48

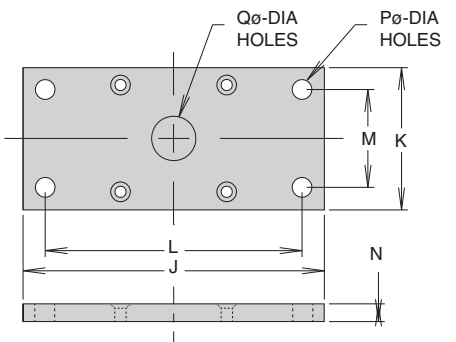

**Shaft Options (A, E, R)**

Units are equipped standard with single male keyed shaft (B, D). Double male keyed (C,F) also available as shown on page 9. Also available:

**Female Keyed (A)  
Metric Female Keyed (E)**

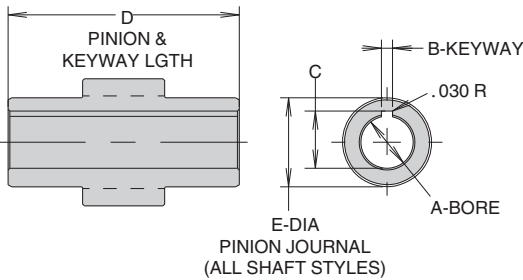

**NOTE:** Female keyed pinions are designed primarily for pneumatic service. Review shaft stresses before using in a hydraulic application.

**Dimensions, inches (A)**

Model	A	B	C	D	E
10	.375 .377	.094 .096	.428 .438	1-13/16	.59
15	.500 .502	.125 .127	.560 .570	2-11/16	.98
20	.750 .752	.187 .189	.837 .847	2-23/32	1.18
25	1.000 1.002	.250 .252	1.083 1.093	3-1/8	1.38
32	1.250 1.252	.250 .252	1.367 1.377	4-9/16	1.77

**Dimensions, mm (E)**

Model	A	B P9	C	D	E
10	9.05 9.00	3	10.65 10.40	46.0	15.0
15	12.05 12.00	4	14.05 13.80	68.3	24.9
20	20.05 20.00	6	23.05 22.80	69.1	30.0
25	25.05 25.00	8	28.55 28.30	79.4	35.1
32	32.05 32.00	10	35.55 35.30	115.9	45.0

**Preload Key (R)\***

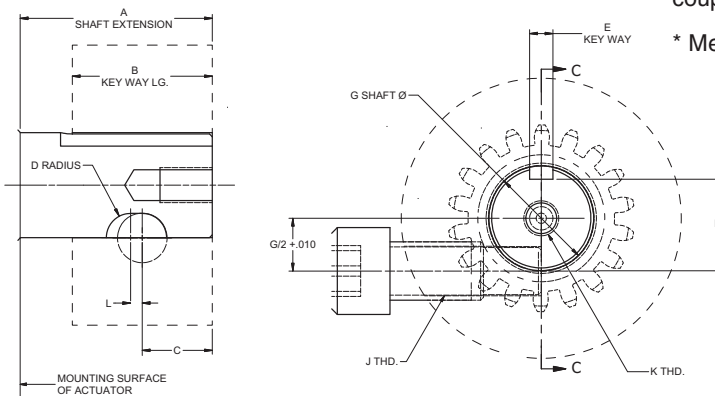

The preload key option is recommended for use with available Parker transition coupler flanges or any time coupling backlash is not desired.

\* Metric preload key option not available as a standard option.

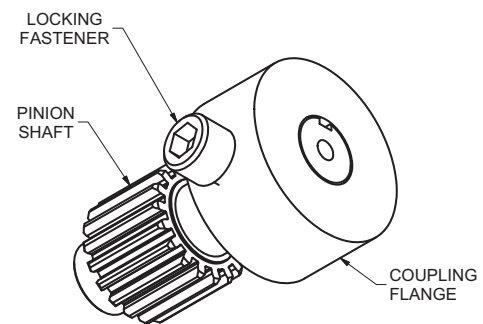
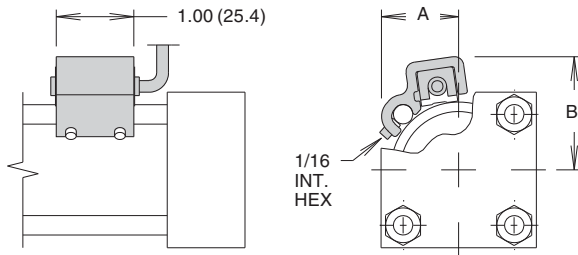

Table											
MODEL	A	B	C	D	E	F	G	H	J	K	L
10	7/8	5/8	.375	.156	.125/ .127	.430/ .425	.500/ .499	1 1/2	3/8-24	10-32 X 3/8	.125
15	1 7/8	1 1/2	.812	.219	.188/ .190	.771/ .761	.875/ .874	2	1/2-20	5/16-24 X 1/2	.125
20	1 7/8	1 1/2	.812	.250	.250/ .252	.986/ .976	1.125/ 1.124	3	5/8-11	3/8-24 X 9/16	.125
25	2 1/4	1 3/4	1.000	.250	.313/ .315	1.201/ 1.191	1.375/ 1.374	3 1/2	3/4-10	3/8-24 X 9/16	0
30	3 1/2	3	1.500	.437	.375/ .377	1.542/ 1.532	1.750/ 1.749	4	1-8	1/2-20 X 3/4	0

### Magnetic Piston (M)

This option prepares the actuator for use with Reed and Hall Effect switches. The "M" option should be specified to provide a magnet on the cylinder piston and aluminum cylinder tubes. *The pressure of the actuator is derated by 50% with the magnetic piston option due to the aluminum cylinder tubes.*

Order switches separately from the Sensors section.



Model	A inch (mm)	B inch (mm)
10	.84 (21)	1.22 (30)
15	.99 (25)	1.46 (37)
20	1.27 (32)	1.68 (43)
25	1.45 (37)	1.89 (48)
32	1.71 (43)	2.20 (56)

### Shaft Seal Covers (S)

Shaft Seal covers are designed to prolong bearing life by isolating them from external contamination and pressure. They are designed for use with standard male shafts only (not hollow shafts). *Shaft seals are not available with flange mounting.*

#### SPECIFICATIONS

**Max. Pressure Differential:** 500 psi (34 Bar)

**Material:** Anodized Aluminum

**Shaft Seal:** Double Lip Wiper

**Body Seal:** O-Ring

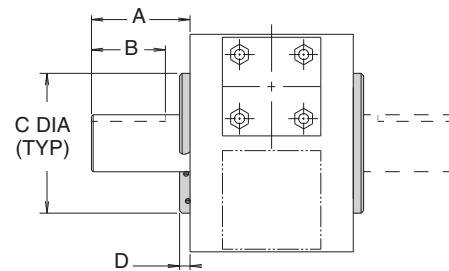

Model	A		B		C		D	
	Inch	mm	Inch	mm	Inch (+.000, -.002)	mm (+.00, -.05)	Inch	mm
10	7/8	22	1/2	12	1.875	48	.25	7
15	17/8	46	15/16	33	3.000	76	.38	10
20	17/8	46	15/16	33	3.250	83	.38	10
25	2 1/4	56	1 5/8	41	3.625	92	.38	10
32	3 1/2	88	2 7/8	73	4.480	114	.38	10

**Piston Seals (V,W)**

The floating Wear-Pak piston fitted as standard to all LTR Series rotary actuator employs a filled PTFE wear band to prevent metal-to-metal contact. The hydraulic LTR Series actuator uses a Molythane Polypak seal, which is self-energizing for improved sealing. The Molythane seal is wear, roll and extrusion resistant. For higher temperatures or use with synthetic fluids, Fluorocarbon seals should be specified; for water glycol or high water content fluids, carboxilated nitrile seals are available.

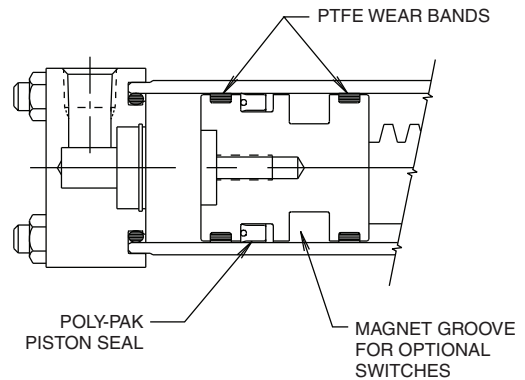

**FILTRATION**

Effective filtration is vital to the long life and satisfactory performance of a rotary actuator. If the piston seals of a rack and pinion rotary actuator are worn or damaged, fluid leaks past the piston and will enter the gear housing.

Any external leakage from the gear housing indicates worn or damaged piston seals. Seals and tubes should be examined and, if necessary, be replaced at the earliest opportunity.

**SEAL OPTIONS**

Seal Option Code	Seal Type	Wear Ring Type	Fluid Medium	Temperature Range	Hydraulic Filtration
Omit (Standard)	Molythane	Filled PTFE	General purpose applications, petroleum-based fluids	-40° to 180°F (-40° to 82°C)	ISO Class 17/14 Cleanliness Level
Option V	Fluorocarbon	Filled PTFE	High temperature operation, special synthetic fluids	-20° to 250°F (-29° to 121°C)	
Option W	Carboxilated Nitrile	Filled PTFE	Water-based fluids	30° to 180°F (0° to 82°C)	

**Feedback Packages**

Feedback packages available for use with LTR Series rotary actuators include:

- Precision feedback potentiometer (J)
- Precision resolver feedback (H)

The feedback packages may be ordered as part of the model code. See Sensors section for specifications.

### Switch Characteristics

#### Proximity Switches

- End Cap Mounted
- Solid State Electronics
- LED Indicator
- 10-30 VDC or 50-230 VAC/DC
- PNP and NPN Available
- Senses Cushion Spear on Piston
- Highest Cost
- Long Life

#### Hall Effect Switches

- Fully Adjustable Travel
- Solid State Electronics
- LED Indicator
- 50-30 VDC
- PNP and NPN Available
- Senses magnet band on piston (Aluminum cylinders required)
- Medium Cost
- Long Life

#### Reed Switches

- Fully Adjustable Travel
- Mechanical Reed
- LED Indicator
- 50-30 VDC or 85-150 VAC
- Senses magnet band on piston (Aluminum cylinders required)
- Lowest Cost
- Medium Life

### Proximity Switches

The inductive type proximity switch provides end of rotation indication. The non-contact probe senses the presence of the ferrous cushion spear and has no springs, plungers, cams or dynamic seals that can wear out or go out of adjustment. The switch is solid state and meets NEMA 4, 12 & 13 specifications. For ease of wiring, the connector housing is rotatable through 360°. To rotate, lift the cover latch, position, and release.

The switch make/break activation point may occur at 0.125" to ±0.125" from end of stroke. Depending on the actuator size, this distance may cause activation at 2° to 15° before end of stroke.

A standard proximity switch controls 50-230 VAC/DC loads from 5 to 500 mA. The low 1.7 mA off-state leakage current can allow use for direct PLC input. The standard short circuit protection (SCP) protects the switch from a short in the load or line upon sensing such a condition (5 amp or greater current) by assuming a non-conductive mode. The fault condition must be corrected and the power removed to reset the switch preventing automatic restarts.

The low voltage DC switch is also available for use with 10-30 VDC. This switch is in a non-rotatable housing, but does incorporate the short circuit protection.

Both switches are equipped with two LEDs, "Ready" and "Target". The "Ready" LED is lit when power is applied and the cushion spear is not present. The "Target" LED will light and the "Ready" LED will go out when the switch is closed, indicating the presence of the cushion spear. Both LEDs flashing indicates a short circuit condition.

#### NOTES:

1. Available with or without cushions.
2. Not available with stroke adjusters.
3. Pressure rating: 3000 psi
4. Operating temperature: -4°F to 158°F
5. Specify switch type, orientation and voltage when ordering
6. Not available on size 10 units.
7. The low voltage DC switch is available in non-rotatable style only. Consult representative for further information.

### Hall Effect and Reed Switches

Reed and Hall Effect switches are available for use with LTR Series rotary actuators. The "M" option should be specified to provide a magnet on the cylinder piston and to use aluminum cylinders.

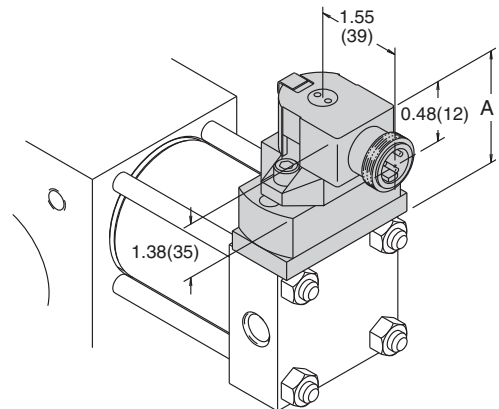

Model	A, inch (mm)
	EPS 6&7
15	2.17 (55.1)
20	2.75 (69.9)
25	2.48 (63.0)
32	2.25 (57.2)

**Order proximity, Hall Effect and reed switches separately. See Sensors section for specifications and ordering information.**







# HTR Series

Hydraulic Rack & Pinion  
Rotary Actuators

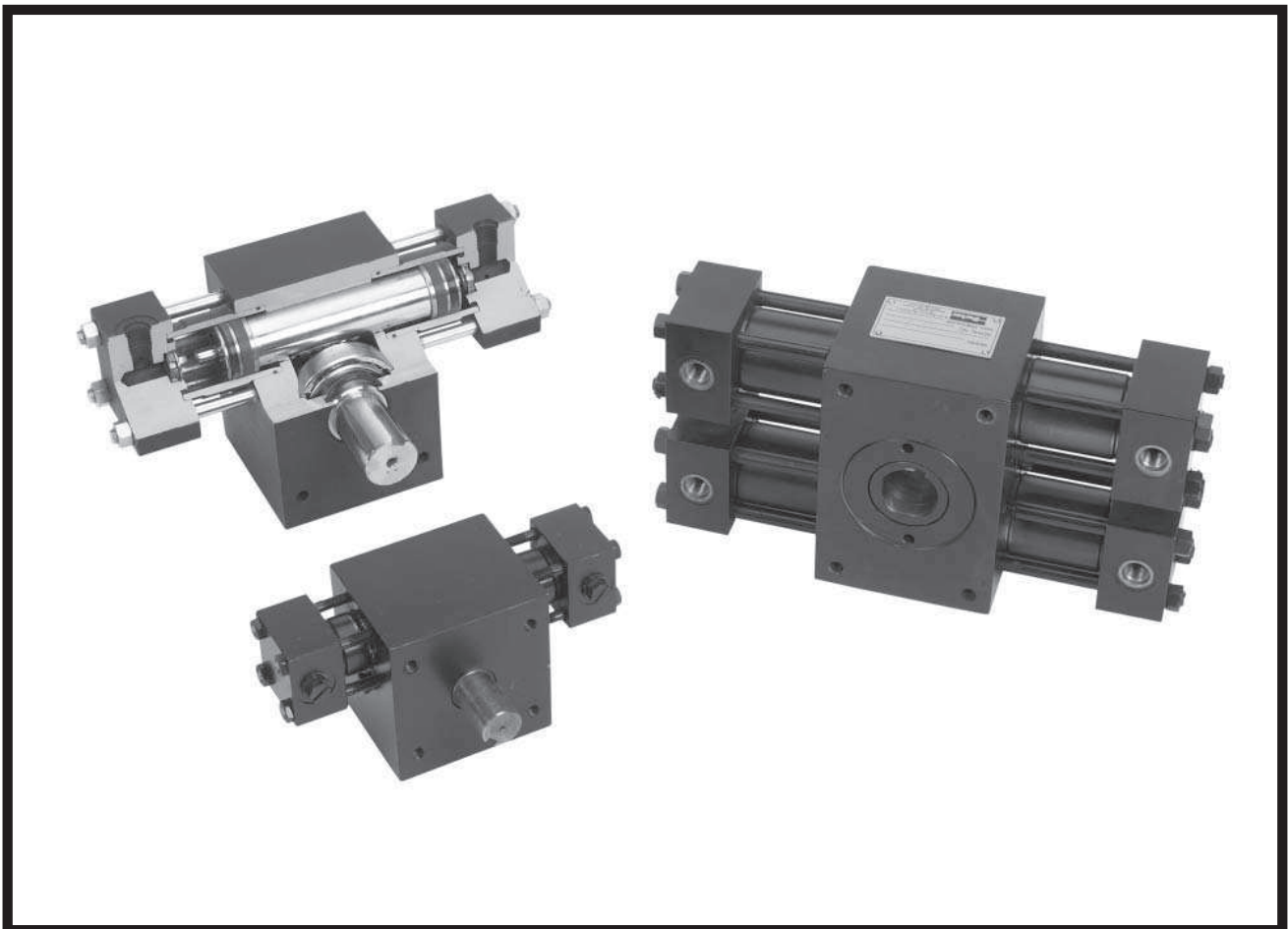

## Contents

Features .....	2
Ordering Information .....	3-4
Specifications .....	5-6
Engineering Data .....	6-8
Dimensional Data .....	9-10
Options	
Cushions .....	11
Stroke Adjusters .....	12

## Options (cont)

Mounting .....	13
Shaft .....	14
Port Threads, Port Location .....	15
Seals .....	16
Proximity Sensors .....	17
Feedback Packages .....	17



**Features**

**Hydraulic Rotary Actuators  
HTR Series**

**RACK & PINION** made from through hardened, high strength alloy steels for long and durable service life in most applications. Option: Case hardening.

**PISTON SEALS**

Depending on actuator size, either dual lip seals made from abrasion resistant polyurethane or heavy duty, deep section Polypak seals made from Molythane for dependable service in most applications. Options: Fluorocarbon seals for certain synthetic fluids; and carboxilated nitrile seals for water based fluids. Piston seals can be inspected and replaced without disconnecting the load from the shaft. (Employ proper safety practices to prevent damage to people or equipment.)

**BRONZE RACK BEARING**

reduces friction, wear and tear between the housing and the rack gear. Replaceable bronze bearing comes standard with HTR15 through HTR600 actuators. High strength bearing material options available.

**WEAR BANDS**

Filled PTFE bands (std) precisely position pistons and prevent side loading from scoring cylinder bores. High strength wear band options available.

**OPTIONAL CUSHIONS**

If properly adjusted, cushions can serve as a braking device for most industrial loads and applications. The proven Parker "floating cushion bushing" serves as a high performance check valve for quick cushion get away and the needle valve can be adjusted to regulate the exhaust flow from the piston. Our design uses no springs or check valve seats that can fatigue or break under normal usage.

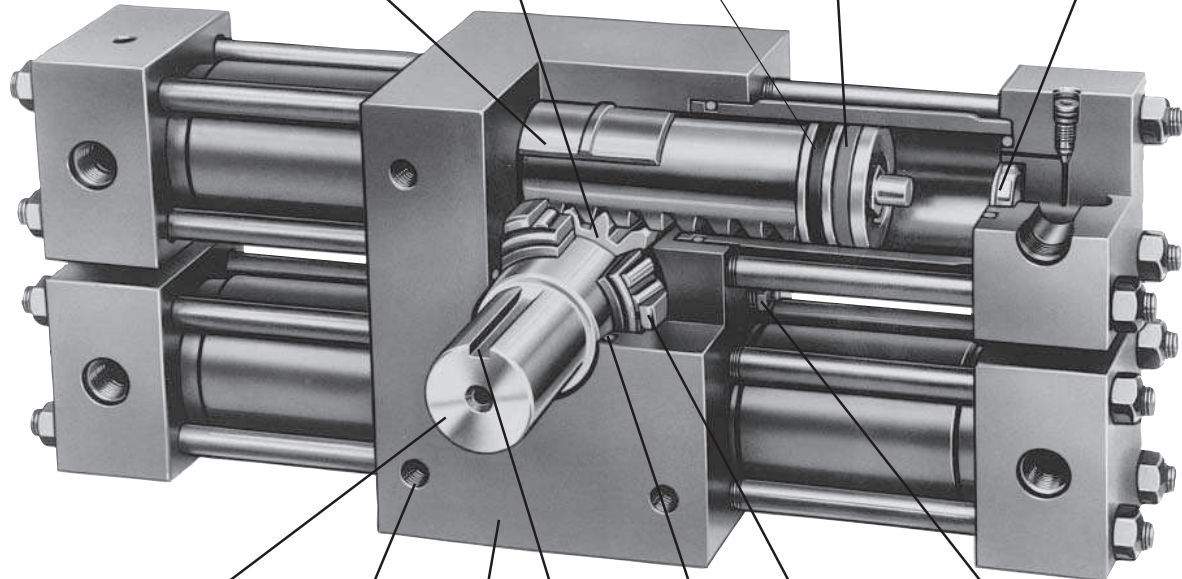

**STANDARD MALE KEYED SHAFT**

is made integral with the pinion gear and is suitable for most applications. Options: double male key, hollow bore keyed and spline shafts are available.

**KEYWAY**

Mid stroke at 12:00 position is standard

**RELIEF VALVE**

is designed to prevent the housing from seeing pressure due to piston seal bypass. Seal kits are available.

**HOUSING**

The heavy, high strength, shock resistant, ductile iron housing serves as a firm base to drive large output torque requirements.

**PINION SEALS**

Dual lobed seal of abrasion resistant materials seals effectively with minimum wear at dynamic conditions.

**TAPERED ROLLER BEARINGS**

are generously sized to support large external axial and radial loads applied to the shaft.

**THREADED MOUNTING HOLES**

Our standard mounting uses four bolt holes drilled and tapped on the front and back of the housing. Options: additional pilot ring or base mount.

Model Code and Ordering Information

Example: HTR150-1803C-AB11VJ-C

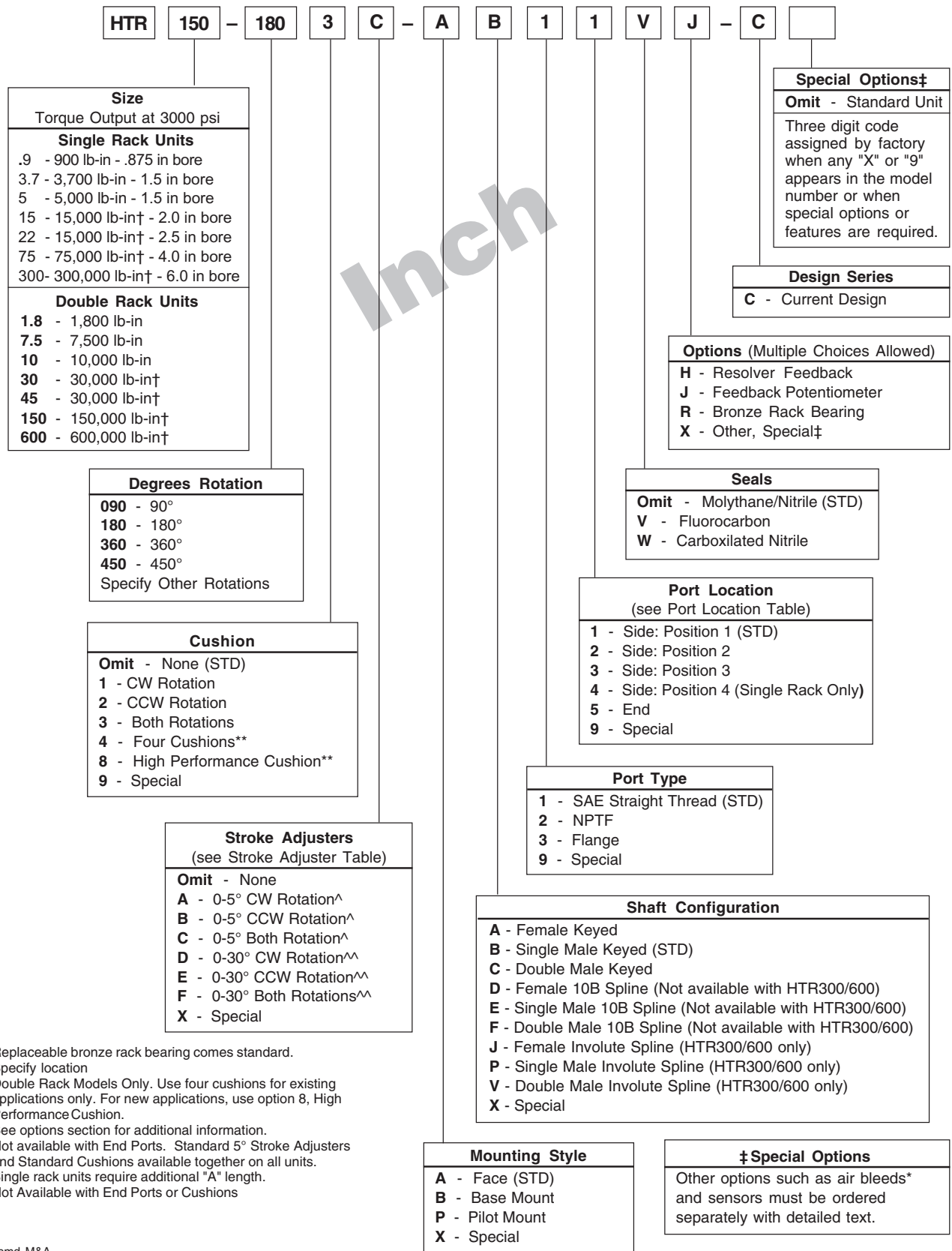

Rack & Pinion Actuators

LTR

HTR

M

† Replaceable bronze rack bearing comes standard.  
 \* Specify location  
 \*\* Double Rack Models Only. Use four cushions for existing applications only. For new applications, use option 8, High Performance Cushion.  
 See options section for additional information.  
 ^ Not available with End Ports. Standard 5° Stroke Adjusters and Standard Cushions available together on all units. Single rack units require additional "A" length.  
 ^^ Not Available with End Ports or Cushions



Model Code and Ordering Information

Example: HTR150-1803C-DG41VJ-C

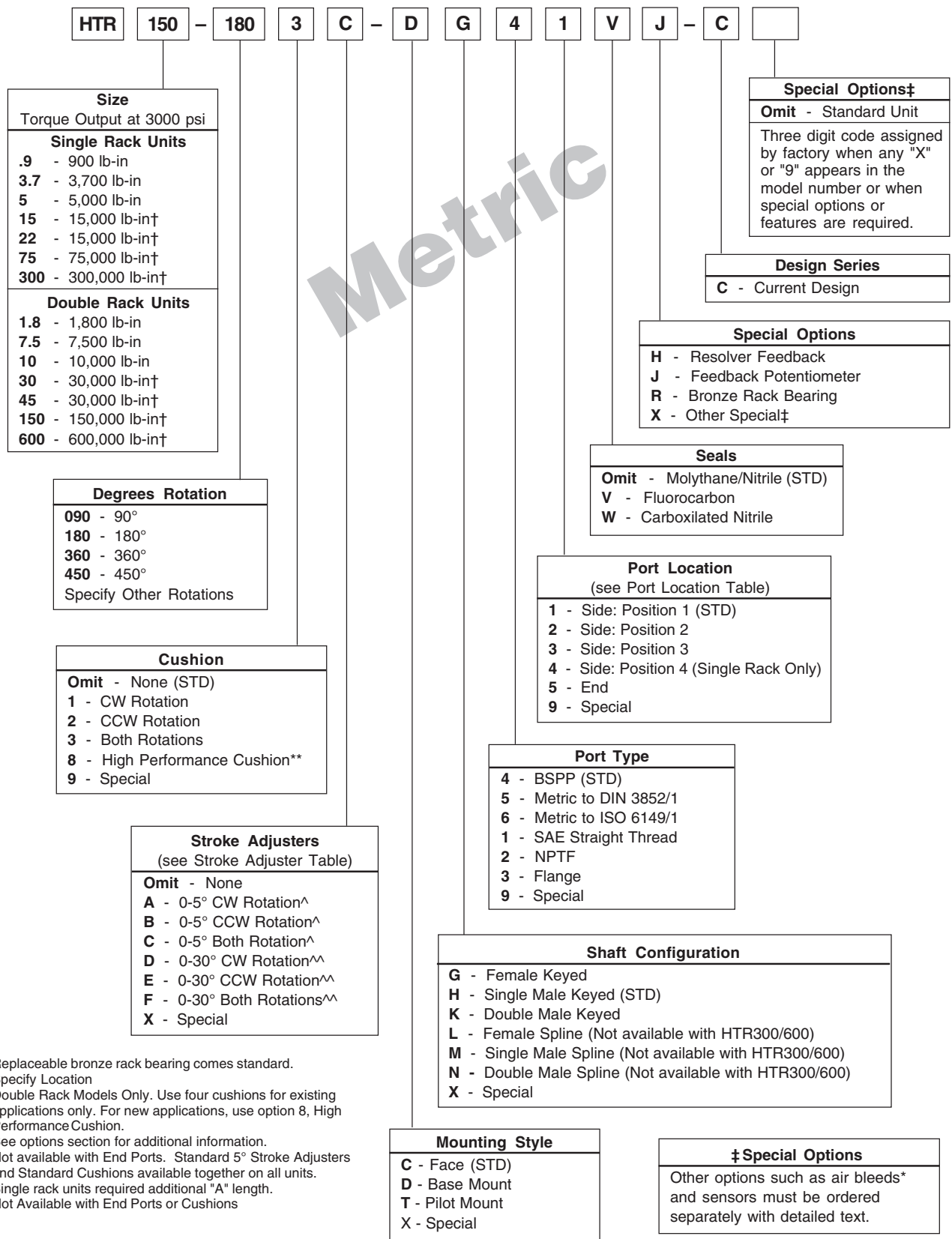

† Replaceable bronze rack bearing comes standard.

\* Specify Location

\*\* Double Rack Models Only. Use four cushions for existing applications only. For new applications, use option 8, High Performance Cushion.

See options section for additional information.

^ Not available with End Ports. Standard 5° Stroke Adjusters and Standard Cushions available together on all units.

Single rack units required additional "A" length.

^^ Not Available with End Ports or Cushions

## HTR Series

The HTR Series actuator incorporates many hydraulic and mechanical features that make this actuator suitable for high production applications. These features include: high load capability tapered roller bearings; a chrome alloy steel rack and pinion gear set; a high strength ductile iron or steel housing; and proven Parker Hannifin cylinder components. These features make the HTR Series actuators robust and suitable for integration into the most demanding production systems.

The HTR Series actuators have been successfully employed in automotive plant production machinery; machine tool equipment; plastics and rubber processing machinery; basic metals production machinery and in material handling machinery.

The HTR Series actuator can be employed as an integral machine component. For example, the actuator can simultaneously transmit torque and support the line shaft or the load. Such an arrangement eliminates one set of external support bearings. For example: the optional cushions can be employed to decelerate an external load. This feature eliminates the need for an external deceleration device such as a shock absorber or a brake.

Additionally, the HTR actuator can simplify the installation of machine parts. For example: The hollow shaft feature can eliminate a coupling. The actuator shaft can be connected to the line shaft by means of a square shaft key; or the housing can be drilled and tapped to mount various brackets.

The Wear-Pak® piston uses self energizing molythane piston seals. These are the only pressurized dynamic seals. The pinion shaft uses low pressure seals. These polypak piston seals can be inspected and serviced while the actuator remains installed on the machinery.

## SPECIFICATIONS

- Maximum operating pressure: 3000 psi (207 Bar) non-shock  
except HTR22/45: 2000 psi (138 Bar) non-shock
- Standard rotations: 90°, 180°, 360°, 450°
- Rotational tolerance: -0°, +2°
- Output torques @ 3000 psi (204 Bar): 900 lb-in to 600,000 lb-in
- Maximum breakaway pressure: 70 psig (4.8 Bar)
- Mounting orientation: unrestricted
- Operating temperature range:
  - Nitrile seals -40° to 180°F (-40° to 82°C)
  - Fluorocarbon seals -20° to 250°F (-29° to 121°C)
- Standard timing: Keyway in 12:00 position at midstroke
- Recommended filtration: ISO class 17/14 or cleaner

**Specifications**

**Hydraulic Rotary Actuators  
HTR Series**

Model		Maximum Pressure Rating, psi (Bar)	Actual Output Torque, lb-in (Nm) at Specified Pressure			Gear Train Rating Durability <sup>(1)</sup>		Maximum Angular Backlash, Minutes <sup>(4)</sup>	Standard Rotation Degrees	Displacement in <sup>3</sup> (cm <sup>3</sup> )	Standard Unit Weight, lb (kg)
Single Rack	Double Rack		1000 psi (69 Bar)	2000 psi (138 Bar)	3000psi (207 Bar)	lbf-inch <sup>(2)</sup>	PSID <sup>(3)</sup>				
HTR.9		3000 (204)	300 (34)	600 (68)	900 (102)	400	1340	45	90	0.57 (9.3)	11 (5)
									180	1.13 (19)	14 (6)
									360	2.27 (37)	20 (9)
HTR1.8		3000 (204)	600 (68)	1200 (136)	1800 (203)	850	1420	45	90	1.13 (19)	16 (7)
									180	2.27 (37)	19 (9)
									360	4.53 (74)	25 (11)
HTR3.7		3000 (204)	1250 (141)	2500 (283)	3700 (418)	1570	1300	40	90	2.43 (40)	28 (13)
									180	4.86 (80)	31 (14)
									360	9.71 (159)	37 (17)
HTR7.5		3000 (204)	2500 (283)	5000 (565)	7500 (848)	3330	1350	40	90	4.86 (79)	35 (16)
									180	9.71 (159)	41 (19)
									360	19.4 (318)	53 (24)
HTR5		3000 (204)	1650 (186)	3300 (373)	5000 (565)	2700	1620	30	90	3.12 (51)	37 (17)
									180	6.25 (102)	39 (18)
									360	12.50 (205)	49 (22)
HTR10		3000 (204)	3300 (373)	6600 (746)	10000 (1130)	5725	1720	30	90	6.25 (102)	45 (20)
									180	12.50 (205)	54 (25)
									360	25.0 (410)	66 (30)
HTR15		3000 (204)	5000 (565)	10000 (1130)	15000 (1695)	9300	1860	25	90	8.9 (145)	55 (25)
									180	17.8 (291)	60 (27)
									360	36.5 (582)	70 (32)
HTR30		3000 (204)	10000 (1130)	20000 (2260)	30000 (3390)	19700	1970	25	90	17.8 (291)	89 (40)
									180	35.5 (582)	97 (44)
									360	71.0 (1164)	117 (53)
HTR22		2000 (136)	7500 (848)	15000 (1695)	—	9300	1240	25	90	13.9 (227)	60 (27)
									180	27.8 (455)	66 (30)
									360	55.5 (910)	79 (36)
HTR45		2000 (136)	15000 (1695)	30000 (3390)	—	19700	1320	25	90	27.8 (455)	98 (45)
									180	55.5 (910)	108 (49)
									360	111 (1819)	134 (61)
HTR75		3000 (204)	25000 (2825)	50000 (5650)	75000 (8475)	25000	1000	25	90	46 (754)	197 (90)
									180	92 (1508)	219 (100)
									360	184 (3016)	263 (120)
HTR150		3000 (204)	50000 (5650)	100000 (11300)	150000 (16950)	53000	1060	25	90	92 (1508)	321 (146)
									180	184 (3016)	367 (167)
									360	368 (6032)	454 (206)
HTR300		3000 (204)	100000 (11300)	200000 (22600)	300000 (33900)	125000	1250	20	90	178 (2913)	760 (345)
									180	355 (5827)	840 (382)
									360	711 (11653)	910 (414)
HTR600		3000 (204)	200000 (22600)	400000 (45200)	600000 (67800)	265000	1325	20	90	355 (5827)	1110 (505)
									180	711 (11653)	1260 (573)
									360	1241 (23290)	1560 (709)

1. The durability is defined as the capacity of the gear set to support the stated load without fatigue related gear surface damage. Use the durability ratings for high production duty of 1 million cycles and/or high speed applications (180° in less than three seconds or more than one cycle per minute).
2. Durability rated output torque.
3. Pressure differential between the inlet and outlet ports (non shock).
4. To minimize backlash in the actuator, order a double rack a few degrees longer and add stroke adjusters.



### Kinetic Energy Capacity

The energy values below assume drive pressure is maintained through cushion stroke.

#### Single Rack Units with Single Set of Cushions (20°)

Model	Kinetic Energy Rating(in-lb) of Cushion at Specified Drive Pressure*											
	0 psi		500 psi		1000 psi		1500 psi		2000 psi		2500 psi	
	Max.	Durability	Max.	Durability	Max.	Durability	Max.	Durability	Max.	Durability	Max.	Durability
HTR.9	314	140	262	140	209	140	157	140	105	105	52	52
HTR3.7	1309	548	1091	548	872	548	654	548	436	436	218	218
HTR5	1745	942	1454	942	1163	942	873	873	582	582	291	291
HTR15	5235	3246	4362	3246	3490	3246	2618	2618	1745	1745	872	872
HTR22	5235	3246	3926	3246	2618	2618	1309	1309	0	0	0	0
HTR75	26175	8725	21812	8725	17448	8725	13088	8725	8724	8724	4362	4362
HTR300	104700	43625	87247	43625	69793	43625	52350	43625	34897	34897	17449	17449

#### Double Rack Units with Single Set of Cushions (20°)

Model	Kinetic Energy Rating(In-lb) of Cushion at Specified Drive Pressure*											
	0 psi		500 psi		1000 psi		1500 psi		2000 psi		2500 psi	
	Max.	Durability	Max.	Durability	Max.	Durability	Max.	Durability	Max.	Durability	Max.	Durability
HTR1.8	314	140	209	140	105	105	0	0	0	0	0	0
HTR7.5	1309	548	873	548	436	436	0	0	0	0	0	0
HTR10	1745	942	1163	942	582	582	0	0	0	0	0	0
HTR30	5235	3246	3490	3246	1745	1745	0	0	0	0	0	0
HTR45	5235	3246	2618	2618	0	0	0	0	0	0	0	0
HTR150	26175	8725	17450	8725	8727	8725	0	0	0	0	0	0
HTR600	104700	43625	69801	43625	34907	34907	0	0	0	0	0	0

#### Double Rack Units with Double Set of Cushions (20°)\*\*

Model	Kinetic Energy Rating(In-lb) of Cushion at Specified Drive Pressure*											
	0 psi		500 psi		1000 psi		1500 psi		2000 psi		2500 psi	
	Max.	Durability	Max.	Durability	Max.	Durability	Max.	Durability	Max.	Durability	Max.	Durability
HTR1.8	628	297	523	297	419	297	314	297	209	209	105	105
HTR7.5	2618	1162	2181	1162	1745	1162	1309	1162	872	872	436	436
HTR10	3490	1998	2908	1998	2326	1998	1745	1745	1163	1163	582	582
HTR30	10470	6875	8725	6875	6979	6875	5235	5235	3490	3490	1745	1745
HTR45	10470	6875	7853	6875	5235	5235	2618	2618	0	0	0	0
HTR150	52350	18497	43623	18497	34897	18497	26175	18497	17448	17448	8725	8725
HTR600	209400	92485	174493	92485	139586	92485	104700	92485	69793	69793	34899	34899

\* Must deduct work (energy) done to overcome potential energy effects of load.  $W_{PE} = T_{PE} \times \theta$ , where  $\theta$  is in radians.

\*\* Extreme care must be exercised so that both cushions are adjusted equally for each direction or dangerous pressure intensification and gear train stresses could result. (Suggest high performance cushion option.)

### Cushion Deceleration and Control

The cushion causes the resisting torque that can be used to decelerate a rotational load. Please note the cushion has to provide enough resistance to control: drive torque caused by the hydraulic system pressure; plus the torque caused by gravity pulling on the rotational load; and the kinetic energy associated with the motion of the inertia load. Since the actuator's cushion has to be able to control the sum of all three torque factors, we suggest including cushion capacity as one of the actuator's selection criteria.

It is strongly suggested that proportional valves be used instead of cushions to control (decelerate) high inertial loads. This provides the ability to reduce inlet pressure while generating deceleration pressure. It also allows for longer ramp times, thus increasing deceleration stroke.

HTR.pmd, M&A

#### SUPPLEMENTAL INFORMATION KINETIC ENERGY BASIC FORMULA

$$KE = 1/2 J_m \omega^2$$

$$\omega = 0.0175 \times \frac{2\Theta_A + \Theta_C + 2\Theta_D}{\text{Rotation Time (sec.)}}$$

where:

KE = Kinetic Energy (in-lb)

$J_m$  = Rotational Mass Moment of Inertia (in-lb-sec<sup>2</sup>)

See page 8 of LTR Section for formulas.

$\omega$  = Peak Velocity (rad/sec)

(Assuming trapezoidal velocity profile)

$\Theta_A$  = Acceleration Angle (deg)

$\Theta_C$  = Constant Velocity Angle (deg)

$\Theta_D$  = Deceleration Angle (deg)

**Bearing Load Capacities**

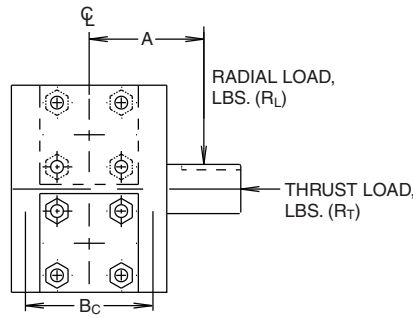

Dynamic <sup>1</sup> Bearing Load Capacities vs. Operating Pressure										
Model	Radial Load (lbs.) $R_L$ (Per Bearing) @			Thrust Load (lbs.) $R_T$ @			Bearing Centers ( $B_c$ )	Overhung Moment (lb-in) $R_L \times (A+B_c/2)$ @		
	1,000 psid (69 bar)	2,000 psid (138 bar)	3,000 psid (207 bar)	1,000 psid (69 bar)	2,000 psid (138 bar)	3,000 psid (207 bar)		1,000 psid (69 bar)	2,000 psid (138 bar)	3,000 psid (207 bar)
HTR.9	3927	3824	3722	2690	2590	2490	0.62	2435	2371	2307
HTR1.8	4030	4030	4030	2790	2790	2790	0.62	2499	2499	2499
HTR3.7	6448	6146	5843	3610	3360	3120	1.06	6835	6514	6194
HTR7.5	6750	6750	6750	3830	3830	3830	1.06	7155	7155	7155
HTR5	8258	7956	7653	4240	4020	3810	1.02	8423	8115	7807
HTR10	8560	8560	8560	4460	4460	4460	1.02	8731	8731	8731
HTR15	14823	14286	13748	12300	11810	11330	1.83	27126	26143	25160
HTR30	15360	15360	15360	12780	12780	12780	1.83	28109	28109	28109
HTR22	14521	13681	na	12060	11330	na	1.83	26573	25037	na
HTR45	15360	15360	na	12780	12780	na	1.83	28109	28109	na
HTR75	20471	18322	16174	16540	14060	11570	3.99	81680	73106	64533
HTR150	22620	22620	22620	19020	19020	19020	3.99	90254	90254	90254
HTR300	38355	33520	28686	24090	19710	15340	5.95	228214	199447	170680
HTR600	43190	43190	43190	28460	28460	28460	5.95	256981	256981	256981

**NOTE:**

1. Static Bearing Load Capacities = Dynamic Values x 1.5
2. Values listed are "Bearing" moment capacities. Standard male shaft sizes do not provide 4:1 design factor at these operating conditions. Larger shaft sizes are available. Consult factory for further details.

**Lubrication**

In general, low speed, high torque applications require class 5 or class 6 lubrication provisions. Our assemblers use TEXACO MOLYTEX EP(2) extreme pressure grease to lubricate our gear sets as our standard lubricant. The grease should be replaced with each major overhaul.

Some high cycle applications with an operational system pressure below 1000 PSIG (69 Bar) and with adequate mechanical shock control may successfully use the hydraulic fluid as the gear train lubricant. We can modify the housing by adding a case drain line to carry away excessive lubricant. Ensure the case drain connection is looped to ensure the housing remains filled with lubricant.

High performance applications that feature high pressure and high cycle rates should consider using an external lubrication circuit system to charge the gear set with clean, cool lubricant suitable for class 3 or 4 service. An SAE80 or SAE90 lubricant circulating system should be suitable. We can modify the housing for a lubrication circuit inlet and outlet. Ensure the plumbing is run in such a way the housing remains filled with lubricant.



**HTR.9 thru HTR10 Single and Double Rack  
 Inch Units with Face Mount (A) and Male Keyed Shaft (B)  
 Metric Units with Face Mount (C) and Male Keyed Shaft (H)**

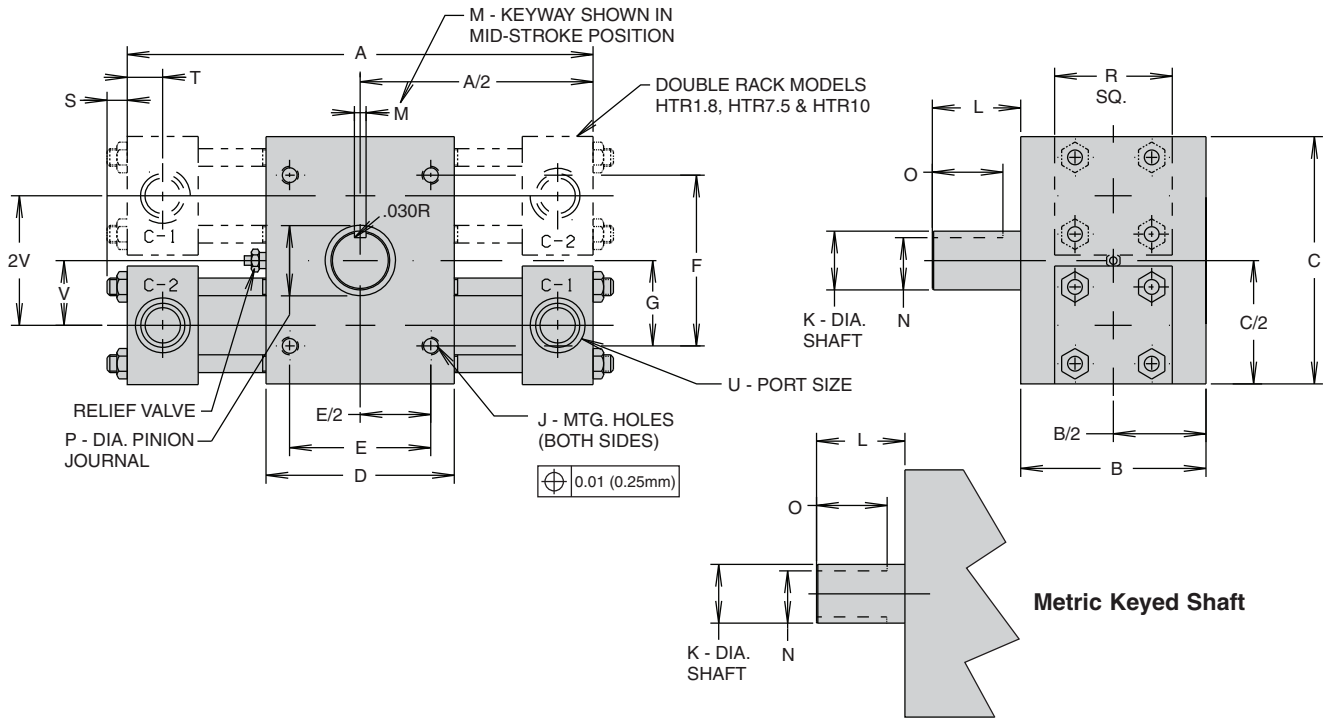

**Rack & Pinion Actuators**

LTR

HTR

M

**Dimensions for Inch Units (inches)**

Model	Rotation Degrees	A	B	C	D	E	F	G	J	K	L	M	N	O	P	R	S	T	U (SAE)	V
HTR.9 HTR1.8	90	7 <sup>1</sup> / <sub>4</sub>	3	3 <sup>5</sup> / <sub>8</sub>	3 <sup>1</sup> / <sub>2</sub>	2.625	2.375	1.188	5 <sup>5</sup> / <sub>16</sub> -18 x 1/2 DP	.875 .874	1 <sup>5</sup> / <sub>16</sub>	.250 .252	.732 .722	1	1	1 <sup>3</sup> / <sub>4</sub>	3 <sup>3</sup> / <sub>8</sub>	.50	9 <sup>16</sup> / <sub>16</sub> -18 (#6)	0.94
	180	9 <sup>1</sup> / <sub>8</sub>																		
	360	12 <sup>7</sup> / <sub>8</sub>																		
HTR3.7 HTR7.5	90	10 <sup>7</sup> / <sub>8</sub>	3 <sup>15</sup> / <sub>16</sub>	5 <sup>1</sup> / <sub>4</sub>	4	3.000	3.625	1.813	3 <sup>8</sup> / <sub>16</sub> -16 x 9 <sup>16</sup> / <sub>16</sub> DP	1.250 1.249	1 <sup>7</sup> / <sub>8</sub>	.311 .312	1.074 1.064	1 <sup>1</sup> / <sub>2</sub>	1 <sup>1</sup> / <sub>2</sub>	2 <sup>1</sup> / <sub>2</sub>	1 <sup>1</sup> / <sub>2</sub>	.72	9 <sup>16</sup> / <sub>16</sub> -18 (#6)	1.38
	180	13 <sup>3</sup> / <sub>8</sub>																		
	360	18 <sup>1</sup> / <sub>4</sub>																		
HTR5 HTR10	90	11 <sup>3</sup> / <sub>8</sub>	3 <sup>15</sup> / <sub>16</sub>	6	4	3.000	5.000	2.500	3 <sup>8</sup> / <sub>16</sub> -16 x 9 <sup>16</sup> / <sub>16</sub> DP	1.750 1.749	2 <sup>5</sup> / <sub>8</sub>	.438 .440	1.500 1.490	2	1 <sup>25</sup> / <sub>32</sub>	2 <sup>1</sup> / <sub>2</sub>	1 <sup>1</sup> / <sub>2</sub>	.72	9 <sup>16</sup> / <sub>16</sub> -18 (#6)	1.63
	180	14 <sup>5</sup> / <sub>8</sub>																		
	360	22 <sup>1</sup> / <sub>8</sub>																		

**Dimensions for Metric Units (mm)**

Model	Rotation Degrees	A	B	C	D	E	F	G	J	K +0,-.02	L	M P9	N	O	P	R	S	T	U BSPP/G	V
HTR.9 HTR1.8	90	184.2	76.2	92.1	88.9	70	60	30	M8 x1.25 x 13 DP	22	33	6	+0,-.1 18.5	25	25.4	44.5	9.5	12.7	1/4	23.8
	180	231.8																		
	360	327.0																		
HTR3.7 HTR7.5	90	257.2	100.0	133.4	101.6	75	90	45	M10 x1.5 x 16 DP	28	48	8	+0,-.2 24	38.1	38.1	63.5	12.7	18.3	1/4	34.9
	180	333.4																		
	360	463.6																		
HTR5 HTR10	90	288.9	100.0	152.4	101.6	75	125	62.5	M10 x1.5 x 16 DP	44	66	12	+0,-.2 39	50	44.5	63.5	12.7	18.3	1/4	41.3
	180	371.5																		
	360	562.0																		

**HTR15 thru HTR600 Single and Double Rack**  
**Inch Units with Face Mount (A) and Male Keyed Shaft (B)**  
**Metric Units with Face Mount (C) and Male Keyed Shaft (H)**

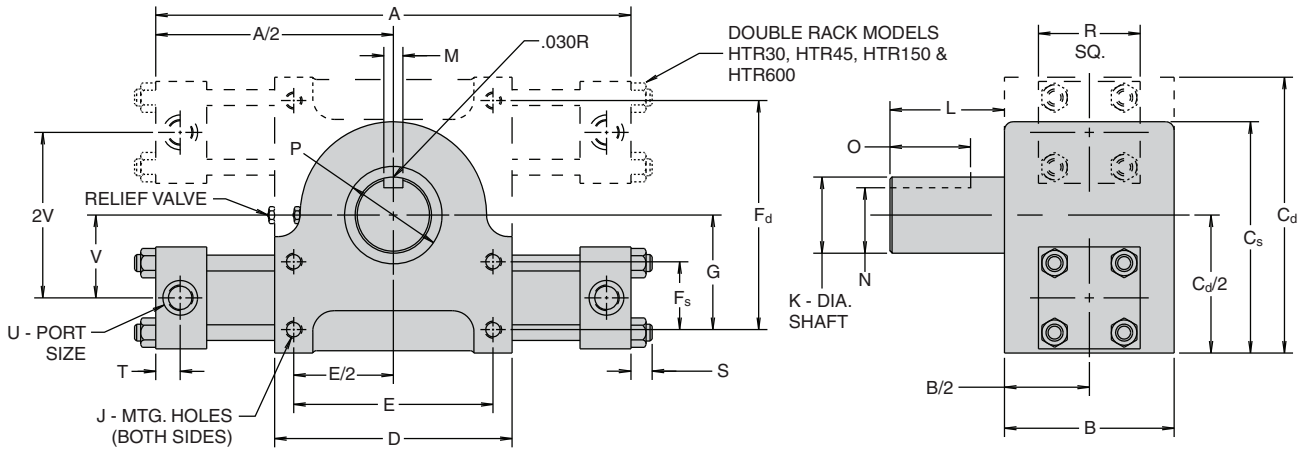

**Dimensions**

Model	Rotation Degrees	A (inch)
HTR15/30	90	16
	180	21 <sup>3</sup> / <sub>8</sub>
	360	32 <sup>1</sup> / <sub>8</sub>
HTR22/45	90	16 <sup>3</sup> / <sub>8</sub>
	180	21 <sup>3</sup> / <sub>4</sub>
	360	32 <sup>3</sup> / <sub>8</sub>
HTR75/150	90	20 <sup>1</sup> / <sub>4</sub>
	180	27 <sup>5</sup> / <sub>8</sub>
	360	42 <sup>1</sup> / <sub>4</sub>
HTR300/600	90	31 <sup>1</sup> / <sub>4</sub>
	180	43 <sup>3</sup> / <sub>4</sub>
	360	68 <sup>7</sup> / <sub>8</sub>

Model	Rotation Degrees	A (mm)
HTR15/30	90	406.4
	180	543.0
	360	816.0
HTR22/45	90	416.0
	180	552.5
	360	822.3
HTR75/150	90	514.4
	180	701.7
	360	1073.2
HTR300/600	90	793.8
	180	1111.3
	360	1749.4

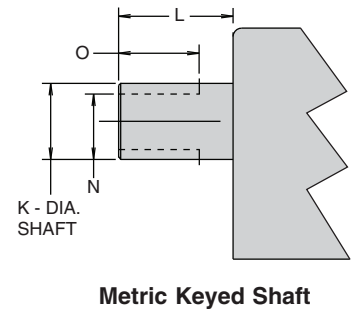

**Dimensions -Inch**

Model	B	Cd	Cs	D	E	Fd	Fs	G	J	K	L	M	N	O	P	R	S	T	U (SAE)	V
HTR15 HTR30	5	— 8 <sup>1</sup> / <sub>8</sub>	6 <sup>13</sup> / <sub>16</sub> —	7	5.875	— 6.750	2.000 —	3.375	1/2-13 x 3/4 DP	2.250 2.249	3 <sup>3</sup> / <sub>8</sub>	.563 .565	1.933 1.923	2 <sup>3</sup> / <sub>8</sub>	2 <sup>7</sup> / <sub>8</sub>	3	5/8	.72	3/4-16 (#8)	2 <sup>7</sup> / <sub>16</sub>
HTR22 HTR45	5	— 8 <sup>3</sup> / <sub>8</sub>	6 <sup>15</sup> / <sub>16</sub> —	7	5.875	— 6.750	2.000 —	3.375	1/2-13 x 3/4 DP	2.250 2.249	3 <sup>3</sup> / <sub>8</sub>	.563 .565	1.933 1.923	2 <sup>3</sup> / <sub>8</sub>	2 <sup>7</sup> / <sub>8</sub>	3 <sup>1</sup> / <sub>2</sub>	5/8	.75	3/4-16 (#8)	2 <sup>7</sup> / <sub>16</sub>
HTR75 HTR150	7 <sup>1</sup> / <sub>2</sub>	— 12 7/8	9 <sup>15</sup> / <sub>16</sub> —	8 <sup>1</sup> / <sub>2</sub>	6.500	— 11.500	4.500 —	5.750	3/4-16 x 1 <sup>1</sup> / <sub>8</sub> DP	3.000 2.999	4 <sup>1</sup> / <sub>2</sub>	.750 .752	2.577 2.567	3 <sup>3</sup> / <sub>8</sub>	3 <sup>3</sup> / <sub>4</sub>	5	1	.84	1 <sup>1</sup> / <sub>16</sub> -12 (#12)	3 <sup>1</sup> / <sub>2</sub>
HTR300 HTR600	12	— 18 <sup>3</sup> / <sub>4</sub>	15 <sup>1</sup> / <sub>4</sub> —	15 <sup>7</sup> / <sub>8</sub>	13.000	— 13.500	5.000 —	7.625 6.750	1 <sup>1</sup> / <sub>4</sub> -7 x 1 <sup>7</sup> / <sub>8</sub> DP	5.000 4.999	7 <sup>1</sup> / <sub>2</sub>	1.250 1.252	4.296 4.286	6	6 <sup>1</sup> / <sub>2</sub>	7 <sup>1</sup> / <sub>2</sub>	1 <sup>1</sup> / <sub>4</sub>	1.25	1 <sup>5</sup> / <sub>16</sub> -12 (#16)	5 <sup>1</sup> / <sub>8</sub>

**Dimensions -Metric (Metric male and female shafts have 2 keyways)**

Model	B	Cd	Cs	D	E	Fd	Fs	G	J	K +0, -.02	L	M P9	N +0, -.2	O	P	R	S	T	U BSPP/G	V
HTR15 HTR30	127.0	— 206.4	174.6 —	177.8	150	— 170	50 —	85	M12x1.75 x19 DP	54	86	16	48	60	73.0	76.2	15.9	18.3	1/2	61.9
HTR22 HTR45	127.0	— 212.7	176.2 —	177.8	150	— 170	50 —	85	M12x1.75 x19 DP	54	86	16	48	60	73.0	88.9	15.9	19	1/2	61.9
HTR75 HTR150	190.5	— 327	254.0 —	215.9	165	— 290	115 —	145	M20x2.5 x30 DP	76	115	22	67	85	95.3	127.0	25.4	21.3	3/4	88.9
HTR300 HTR600	304.8	— 476.3	387.4 —	403.2	330	— 350	125 —	175 195	M30x3.5 x48 DP	125	190	32	114	152	165.1	190.5	31.8	31.8	1	130.2

1800\_HTR.pmd, M&A

Options

**Cushions (1, 2, 3, 4)\***

The standard cushion operates over the last 20° of rotation in either or both directions. A floating bushing ensures no binding of cushion spear. All cushions are fully adjustable.

For severe operating conditions high performance cushions should be fitted on double rack units. On double rack units with only two cushions, cushions are located on upper cylinders.

\* For gear train durability, see chart below.

STANDARD  
CUSHION ADJUSTER  
NEEDLE LOCATIONS

Port Position	Cushion Adjuster Position
1	2
2	3
3	2
4**	3
5	2

\*\*Single rack only.

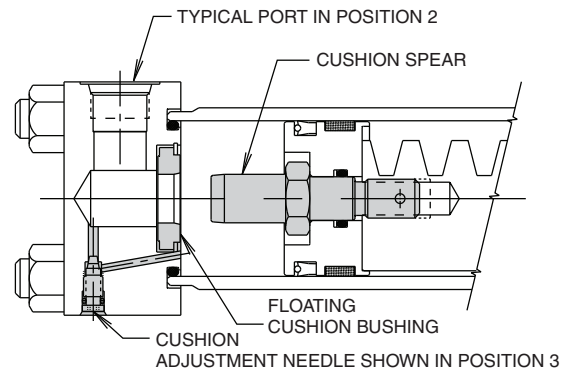

**Suggestions:** Use either Type 4 or Type 8 cushion option with HTR1.8, 7.5, 30, 45, 150 and 600 size actuators. Avoid Type 1, 2 or 3 cushions with double rack units. The use of proportional valves instead of cushions is recommended with high inertial loads.

**High Performance Cushion (8)**

(This option can be specified only with double rack units)

By combining the output/exhaust flow from two cylinders, then routing it through a single cushion bushing and cushion adjuster, cushion performance is enhanced. The increased cushion flow results in better control, doubles the cushioning torque, and eliminates dangerous pressure intensification. This unique circuit also eliminates two pipe or tubing tees.

**OPERATION:**

The work ports of a standard directional valve are plumbed to ports C-1 and C-2. Port A-1 is plumbed directly to A-2, and port B-1 is plumbed to B-2. When pressure is applied to port C-1 (clockwise shaft rotation), fluid is also directed through line A to the other rack. Exhaust flow from B-1 through B-2 is directed through the cushion bushing and cushion adjustment. When the cushion spear closes off the main passage, total flow from both end caps is directed across one cushion adjustment needle, equalizing back pressure and improving performance. Alternatively, pressurizing C-2 and exhausting C-1 reverses the operation.

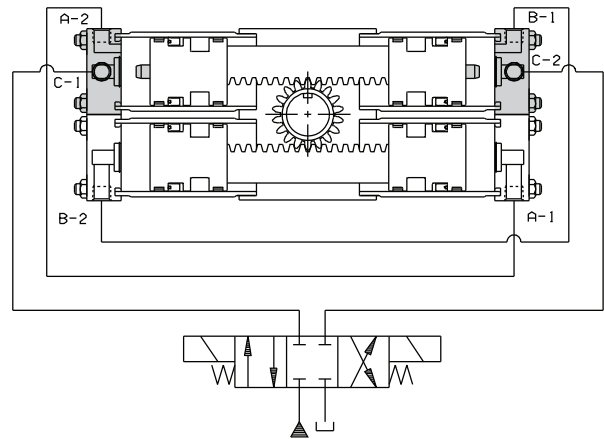

Work Ports C-1, C-2 Port Position	Cushion Adjustment Position	Connection Ports A-1, A-2, B-1, B-2 Port Position
1	2	3
2	3	1
3	2	1
5	2	3

**DIMENSIONAL INFORMATION:**

Units are identical to standard double rack and pinion units, with the exception of porting location. The chart describes the location of the ports.

**GEAR SET DURABILITY**

The table to the right provides energy ratings based on gear train durability when using various cushion options for the HTR Series.

Model	Total Energy Capacity (in-lb)		Port to Port ΔP (PSID)	
	Code 1, 2, 3	Code 8	Code 1, 2, 3	Code 8
HTR.9	140	—	1340	—
HTR1.8	140	297	670	1340
HTR3.7	548	—	1300	—
HTR7.5	548	1162	650	1300
HTR5	942	—	1620	—
HTR10	942	1998	810	1620
HTR15/22	3246	—	1860/1240	—
HTR30/45	3246	6875	930/620	1860/1240
HTR75	8725	—	1000	—
HTR150	8725	18497	500	1000
HTR300	43625	—	1250	—
HTR600	43625	92485	625	1250

**Options**

**Hydraulic Rotary Actuators  
HTR Series**

**Stroke Adjusters**

Fine control of the end of travel points of the rotary actuator can be obtained by specifying stroke adjusters. These operate by reducing the maximum travel of the actuator within preset limits of either 5° or 30° in each direction. Adjustment within this range is variable and may be carried out by the user. Several types of stroke adjusters are available as shown – the designs illustrated are suitable for applications requiring infrequent adjustment.

Limit the setup of stroke adjust to 1-2 adjustments. If frequent adjustments are required, consult factory.

**Stroke Adjusters and Cushions**

5° stroke adjusters may be combined with the cushioning devices shown. 30° stroke adjusters cannot be combined with cushions. The addition of stroke adjusters requires an increase in build length. On double rack units with cushions, the cushion is fitted to the upper rack and the stroke adjuster to the lower. The increase in build length, for both single and double rack units, is shown as dimension A in the table. Cushion performance may be reduced by the addition of a stroke adjuster. Please consult the factory in critical applications.

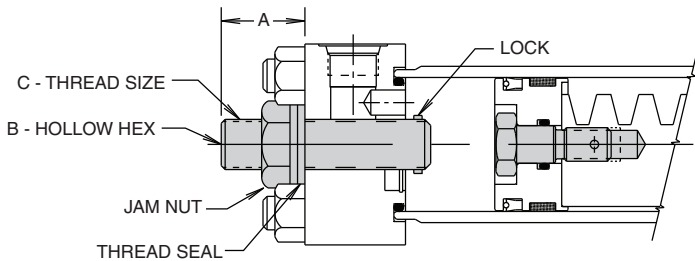

Lock limits unthreading from outside.  
Caution: damage to end cap may result if disassembled in this direction.

**TYPE I STROKE ADJUSTERS, 5° and 30°**

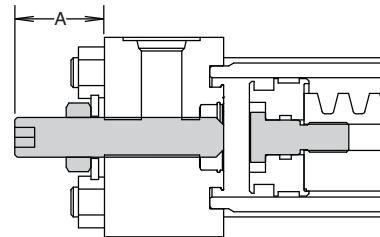

**TYPE II STROKE ADJUSTERS, 5°**

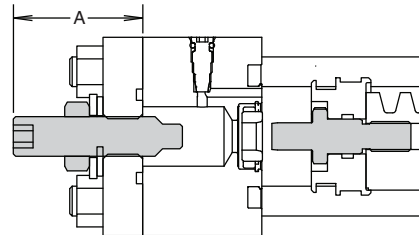

Model	One (1) Turn Adj.	A (Max)						B	C
		TYPE I 5° Adjustment w/o Cushioned End Cap		TYPE II 5° Adjustment w/ Cushioned End Cap		TYPE I 30° Adjustment w/o Cushioned End Cap			
		Inch	mm	Inch	mm	Inch	mm		
HTR.9 HTR1.8	4.2°	.50	12.7	.88	22.4	.75	19.1	5/32	<sup>5</sup> / <sub>16</sub> - 24 UNF
HTR3.7 HTR7.5	3.3°	.63	16	1.13	28.7	1.13	28.7	1/4	1/2 - 20 UNF
HTR5 HTR10	2.5°	.63	16	1.13	28.7	1.13	28.7	1/4	1/2 - 20 UNF
HTR15/30 HTR22/45	2.0°	.88	22.4	1.81	46	1.63	41.4	3/8	<sup>3</sup> / <sub>4</sub> - 16 UNF
HTR75 HTR150	2.0°	2.56	65	3.75	95.3	3.56	90.4	<sup>15</sup> / <sub>16</sub> Ext. Sq.	1 1/2 - 12 UNF
HTR300 HTR600	CONSULT FACTORY								

**Base and Pilot Mounting**

HTR Series rotary actuators are available with the options of face, base, or pilot mounting styles to suit the requirements of different applications. Mounting dimensions for the face mounting styles are shown with other major dimensions on the previous pages. The equivalent dimensions for base and pilot mounting styles are shown in the tables below.

Model	Mounting Hole Bolt Size	Suggested Bolt Torque	Mounting Face Torque Limit*
HTR.9 HTR1.8	5/16-18 UN x 12 dp	126 lb-in	900 lb-in 1800 lb-in
HTR3.7 HTR5	3/8-16 UN x 9/16 dp	300 lb-in	3750 lb-in 7500 lb-in
HTR7.5 HTR10	3/8-16 UN x 9/16 dp	300 lb-in	7500 lb-in 10,000 lb-in
HTR15 HTR22	1/2-13 UN x 3/4 dp	60 lb-ft	15,000 lb-in 15,000 lb-in
HTR30 HTR45	1/2-13 UN x 3/4 dp	60 lb-ft	30,000 lb-in 30,000 lb-in
HTR75 HTR150	3/4-16 UN x 1-1/8 dp	160 lb-ft	63,500 lb-in 99,740 lb-in
HTR300 HTR600	1-1/4-7 UN x 1-7/8 dp	720 lb-ft	300,000 lb-in 600,000 lb-in

\*Without additional reinforcement.

**Mounting Options (B, D, P, T)**

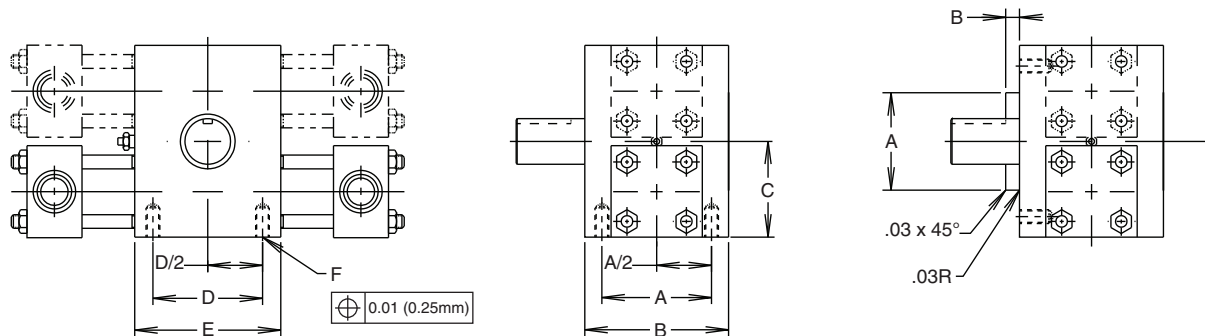

**Base Mounting –Inch (B)**

Model	A	B	C	D	E	F
HTR.9 HTR1.8	2.250	3	1.813	2.625	3 1/2	5/16-18 NC x 1/2 DP
HTR3.7 HTR7.5	3.000	3 15/16	2.625	3.000	4	3/8-16 NC x 9/16 DP
HTR5 HTR10	3.000	3 15/16	3.000	3.000	4	3/8-16 NC x 9/16 DP
HTR15/30 HTR22/45	3.875	5	4.063 4.188	5.875	7	1/2-13 NC x 3/4 DP
HTR75 HTR150	5.750	7 1/2	6.438	6.500	8 1/2	3/4-16 NF x 1 1/8 DP
HTR300 HTR600	9.500	12	9.375	13.000	15 7/8	1 1/4-7 NC x 1 7/8 DP

**Base Mounting –Metric\* (D)**

Model	A	B	C	D	E	F
HTR.9 HTR1.8	60	76.2	46.1	70	88.9	M8 x 1.25 x 13
HTR3.7 HTR7.5	75	100.0	66.7	75	101.6	M10 x 1.5 x 16
HTR5 HTR10	75	100.0	76.2	75	101.6	M10 x 1.5 x 16
HTR15/30 HTR22/45	100	127.0	103.2 106.4	150	177.8	M12 x 1.75 x 19
HTR75 HTR150	145	190.5	163.5	165	215.9	M20 x 2.5 x 30
HTR300 HTR600	240	304.8	238.2	330	403.2	M30 x 3.5 x 48

**Pilot Mounting –Inch (P), Metric (T)**

Model	Inch		Metric*	
	A	B	A	B
HTR.9 HTR1.8	1.875 1.873	1/4	47.63	6.5
HTR3.7 HTR7.5	2.625 2.623	1/4	66.68	6.5
HTR5 HTR10	2.875 2.873	1/4	73.03	6.5
HTR15/30 HTR22/45	4.250 4.248	3/8	107.95	10
HTR75 HTR150	5.500 5.498	3/8	139.67	10
HTR300 HTR600	8.750 8.748	1/2	222.25	12

\*Dimensions given in mm.

**Shaft Options**

**Single Male Keyed (B)**  
Metric version (H) also available

Model	Torque, lb-in	Key Size	Suggested Key Material
HTR.9/HTR1.8	1,800	1/4 x 1/4 x 1	C1018CR
HTR3.7/HTR7.5	7,500	5/16 x 5/16 x 1 1/2	C1018CR
HTR5/HTR10	10,000	7/16 x 7/16 x 2	C1018CR
HTR15/HTR30	30,000	9/16 x 9/16 x 2 3/8	C1018CR
HTR22/HTR45	30,000	9/16 x 9/16 x 2 3/8	C1018CR
HTR75/HTR150	102,000	3/4 x 3/4 x 3 3/8	C1045CR
HTR300/HTR600	475,000	1 1/4 x 1 1/4 x 6	C1018CR

**Female Keyed Shaft (A)**

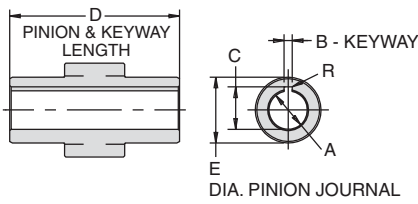

**Metric Female Keyed Shaft (G)**

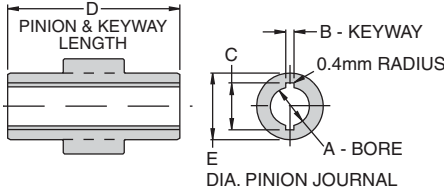

Model	Option A*						Option G (DIN 6885)**				
	A	B	C	D	E	R	A H7	B P9	C +.04	D	E
HTR.9 HTR1.8	.625 .626	.187 .189	.709 .719	2.94	1.00	.030	16	5	20.6	74.6	25.4
HTR3.7 HTR7.5	.875 .876	.187 .189	.964 .974	3.88	1.50	.015	22	6	27.6	98.4	38.1
HTR5 HTR10	1.250 1.252	.250 .252	1.367 1.377	3.88	1.78	.030	32	10	38.6	98.4	44.5
HTR15 HTR30	2.000 2.003	.500 .502	2.223 2.233	4.94	2.88	.030	48	14	55.6	125.4	73.0
HTR22 HTR45	2.000 2.003	.500 .502	2.223 2.233	4.94	2.88	.030	48	14	55.6	125.4	73.0
HTR75 HTR150	2.750 2.755	.750 .753	3.032 3.042	7.44	3.75	.030	72	20	81.8	188.9	95.2
HTR300 HTR600	5.000 5.005	1.250 1.252	5.366 5.376	11.94	6.50	.030	125	32	139.8	303.2	165.1

**Female Splined Shaft (D, L)**

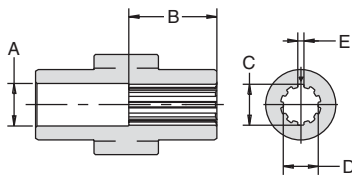

30° involute splined female shafts available for HTR300/600. Consult factory.

Model	Option D (10B Spline)*					Option L (DIN/ISO 14)**					No. of Splines
	A	B	C	D	E	A	B	C	D	E	
HTR.9 HTR1.8	.656 .625	.625 .624	.625 .624	.538 .537	.098 .096	17	16	16	13	3.5	6
HTR3.7 HTR7.5	.906 .875	.875 .876	.875 .876	.753 .752	.137 .135	23	22	22	18	5	6
HTR5 HTR10	1.156 1.250	1.250 1.124	1.125 1.124	.968 .967	.176 .174	29	29	28	23	6	6
HTR15 HTR30	2.031 2.000	2.000 1.998	2.000 1.998	1.720 1.718	.312 .309	49	50	48	42	8	8
HTR22 HTR45	2.031 2.000	2.000 1.998	2.000 1.998	1.720 1.718	.312 .309	49	50	48	42	8	8
HTR75 HTR150	3.031 3.000	3.000 2.998	3.000 2.998	2.580 2.578	.468 .465	73	76	72	62	12	8

**Male Splined Shaft (E, M)**

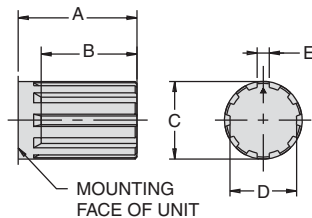

30° involute splined male shafts available for HTR300/600. Consult factory.

\* Dimensions in inches \*\* Dimensions in mm

Model	Option E (10B Spline)*					Option M (DIN/ISO 14)**					No. of Splines
	A	B	C	D	E	A	B	C	D	E	
HTR.9 HTR1.8	1.312 .875	.875 .872	.873 .872	.747 .742	.134 .133	33	22	22	18	5	6
HTR3.7 HTR7.5	1.875 1.250	1.250 1.246	1.248 1.246	1.069 1.064	.192 .191	48	28	28	23	6	6
HTR5 HTR10	2.625 1.750	1.750 1.746	1.748 1.746	1.499 1.494	.270 .269	66	44	42	36	7	8
HTR15 HTR30	3.375 2.250	2.250 2.245	2.247 2.245	1.928 1.923	.347 .346	86	58	54	46	9	8
HTR22 HTR45	3.375 2.250	2.250 2.245	2.247 2.245	1.928 1.923	.347 .346	86	58	54	46	9	8
HTR75 HTR150	4.500 3.000	3.000 2.995	2.997 2.995	2.573 2.568	.464 .463	115	76	72	62	12	8

**Options**

**Port Sizes and Positions**

The standard port styles for HTR Series rotary actuators are SAE and BSP (parallel) port, but NPTF, flanged and metric port styles to DIN 3852/1 and ISO 6149/1 are also available. The relevant sizes of port for each model of rotary actuator are shown.

Ports will be supplied in position 1, as shown in the diagram, unless a different position is specified on the order. Ports are available in positions 2, 3, and 4 at no extra cost; position 5 is available as an extra cost option.

**Air Bleeds**

These may be fitted in end cap positions unoccupied by ports or cushions. Specify location in clear text.

**Port Locations**

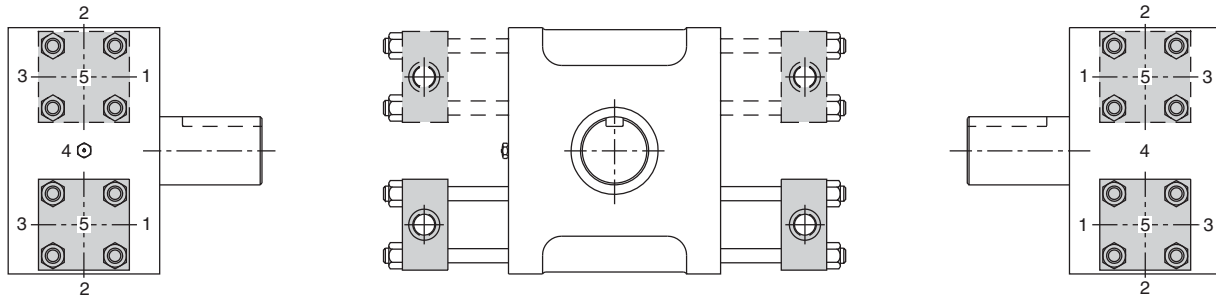

**NOTE:**

1. Port position 1 is standard.
2. Port position 2, 3 and 4 are standard options available at no additional cost.
3. Port position 5 is available at additional cost; not available with stroke adjusters.

**Port Types and Sizes**

Model	Standard SAE Straight Thread (1)	Code 61 SAE Flange (3)	NPT (2) BSPP (4)	Metric DIN (5)* or ISO (6)
HTR.9 HTR1.8	9/16 - 18 (SAE 6)	N/A	1/4	M14 x 1.5
HTR3.7 HTR7.5	9/16 - 18 (SAE 6)	N/A	1/4	M14 x 1.5
HTR5 HTR10	9/16 - 18 (SAE 6)	N/A	1/4	M14 x 1.5
HTR15 HTR30	3/4 - 16 (SAE 8)	Consult Factory	1/2	M22 x 1.5
HTR22 HTR45	3/4 - 16 (SAE 8)	Consult Factory	1/2	M22 x 1.5
HTR75 HTR150	1 1/16 - 12 (SAE 12)	3/4	3/4	M27 x 2
HTR300 HTR600	1 5/16 - 12 (SAE 16)	1	1	M33 x 2

\* DIN 3852/1

\*\* ISO 6149/1 (Not available with HTR.9 or HTR1.8)

**Options**

**Seal Materials (V,W)**

Effective filtration is vital to the long life and satisfactory performance of a rotary actuator. If the piston seals of a rack and pinion rotary are worn or damaged, fluid which leaks past the piston will enter the gear housing.

In the event of internal leakage into the gear housing, the pressure relief valve protects the shaft seal.

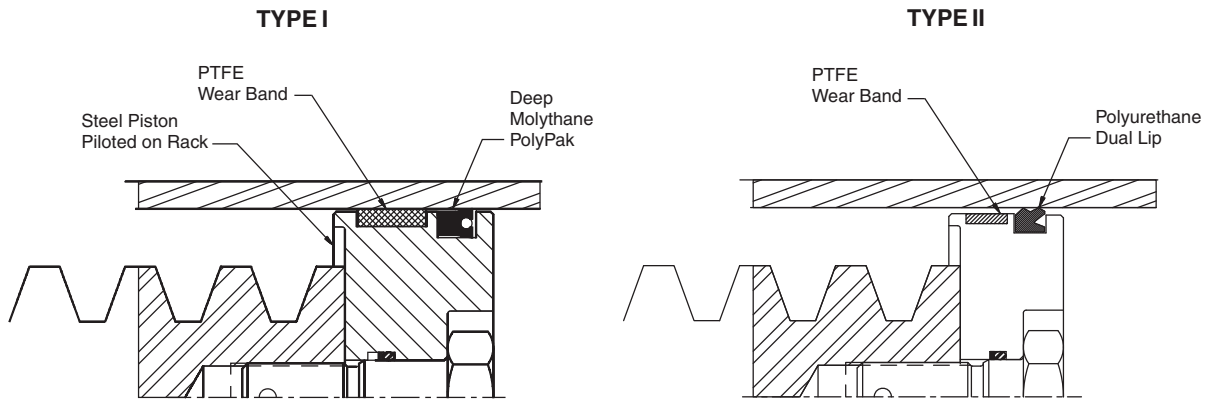

Seal Class	Seal Type	Wear Ring Type	Fluid Medium	Temperature Range	Pressure Range	Filtration
Standard Type I*	Molythane PolyPak	Filled PTFE	General purpose, Petroleum-based fluids	-40°F to 180°F -40°C to 82°C	3000 psi 207 bar	Minimum ISO Class 17/14 Cleanliness Level
Standard Type II**	Polyurethane Dual Lip	Filled PTFE	General purpose, Petroleum-based fluids	-40°F to 180°F -40°C to 82°C	3000 psi 207 bar	
Fluorocarbon (V)	Viton	Filled PTFE	High Temperature and/or Synthetic Fluids	-20°F to 250°F -29°C to 121°C	3000 psi 207 bar	
Nitrile (W)	Carboxilated Nitrile	Filled PTFE	Water Glycol, High Water Content Fluids	30°F to 180°F 0°C to 82°C	2000 psi 138 bar	

\* Standard on HTR.9/1.8, 3.7/7.5, 5/10

\*\* Standard on HTR15/30, 22/45, 75/150 and 300/600

**Seal Kit Ordering Information**

- Standard units are equipped with nitrile seals.
- Optional seal compounds are available.
- See parts list for items contained in seal kits.
- Seal kit part numbers as follows:

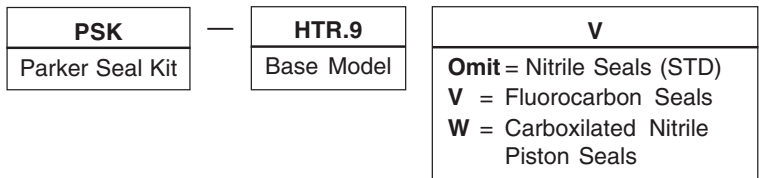

**NOTE:** The seal kit is equipped with parts necessary to re-seal Design Series "A", "B" or "C" HTR Series rotary actuators. If the actuator model number ends in C###, call factory for seal kit part number.



**Proximity Switches  
(Namco Cylinders or  
Balluff Cylinder Indicator Sensor)**

The inductive type proximity switch provides end of rotation indication. The non-contact probe senses the presence of the ferrous cushion spear and has no springs, plungers, cams or dynamic seals that can wear out or go out of adjustment. The switch is solid state and meets NEMA 1, 12 & 13 specifications. For ease of wiring the connector housing is rotatable through 360°. To rotate, lift the cover latch, position and release.

The switch make/break activation point may occur at 0.125" to ±0.125" from the end of stroke. Depending on the actuator size, this distance may cause activation at 2° to 15° from end of stroke.

The standard proximity switch controls 50-230 VAC/DC loads from 5 to 500 mA. The low 1.7 mA off-state leakage current can allow use for direct PLC input. The standard short circuit protection (SCP) protects the switch from a short in the load or line upon sensing such a condition (5 amp or greater current) by assuming a non-conductive mode. The fault condition must be corrected and the power removed to reset the switch preventing automatic restarts.

The low voltage DC switch is also available for use with 10-30 VDC. The switch is in a non-rotatable housing, but does incorporate the short circuit protection.

Both switches are equipped with two LEDs, "Ready" and "Target". The "Ready" LED is lit when power is applied and the cushion spear is not present. The "Target" LED will light and the "Ready" LED will go out when the switch is closed, indicating the presence of the cushion spear. Both LEDs flashing indicates a short circuit condition.

**Order proximity sensors separately. See Sensors section for specifications and ordering information.**

**NOTES:**

1. Available with or without cushions.
2. Not available with stroke adjusters.
3. Pressure rating: 3000 psi
4. Operating temperature: -4°F to 158°F
5. Specify switch type, orientation and voltage when ordering.
6. The low voltage DC switch is available in non-rotatable style only, consult representative for further information.

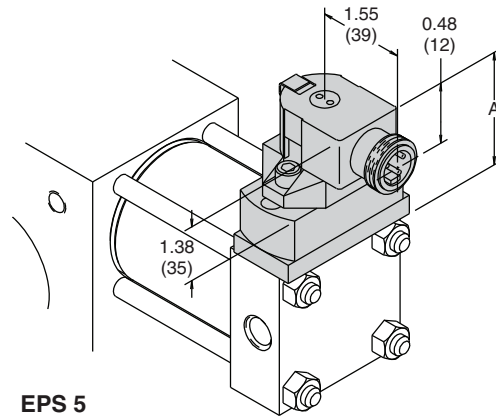

Model	A, inch (mm)	
	EPS 5	EPS 6&7
HTR.9 HTR1.8	1.89 (48.1)	2.21 (56.1)
HTR3.7 HTR7.5	2.38 (60.5)	2.70 (68.6)
HTR5 HTR10	2.38 (60.5)	2.70 (68.6)
HTR15 HTR30	2.32 (58.9)	2.64 (67.0)
HTR22 HTR45	2.05 (52.1)	2.37 (60.2)
HTR75 HTR150	1.55 (39.4)	1.87 (47.5)
HTR300 HTR600	3.14 (79.8)	3.45 (87.6)

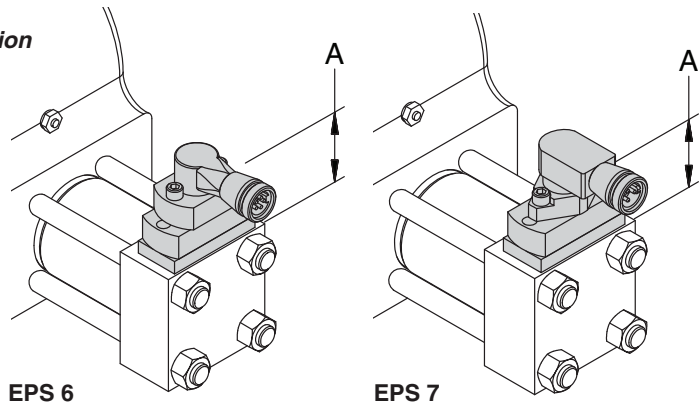

**Feedback Packages**

Feedback packages available for use with HTR Series rotary actuators include:

- Precision feedback potentiometer (J)
- Precision resolver feedback (H)
- Linear potentiometer feedback (Oildyne Teknar)
- LDT feedback (MTS Temposonics)

The feedback potentiometer (J) and resolver feedback (H) may be ordered as part of the model code. The other options must be ordered separately as specials. See Sensors section for specifications.





# M Series

## Heavy Duty Mill Series Rotary Actuators

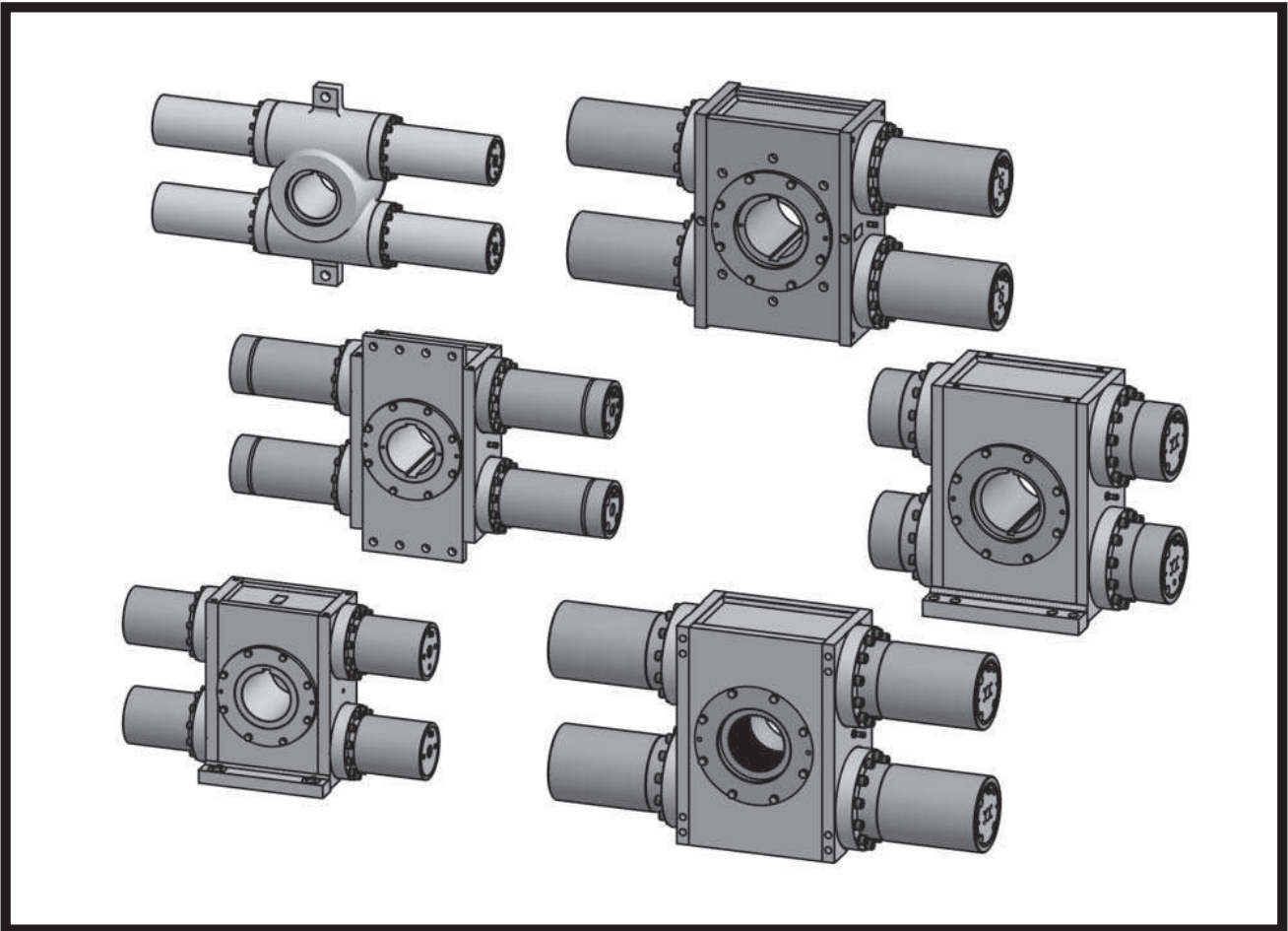

### Contents

Features .....	2
Ordering Information .....	3
Specifications .....	4-5
Engineering Data .....	6-7
Dimensional Data .....	8-10
Options	
Cushions .....	11
Stroke Adjusters .....	11

### Options (cont)

Mounting .....	12-13
Shafts .....	14
Ports .....	15
Seals .....	15



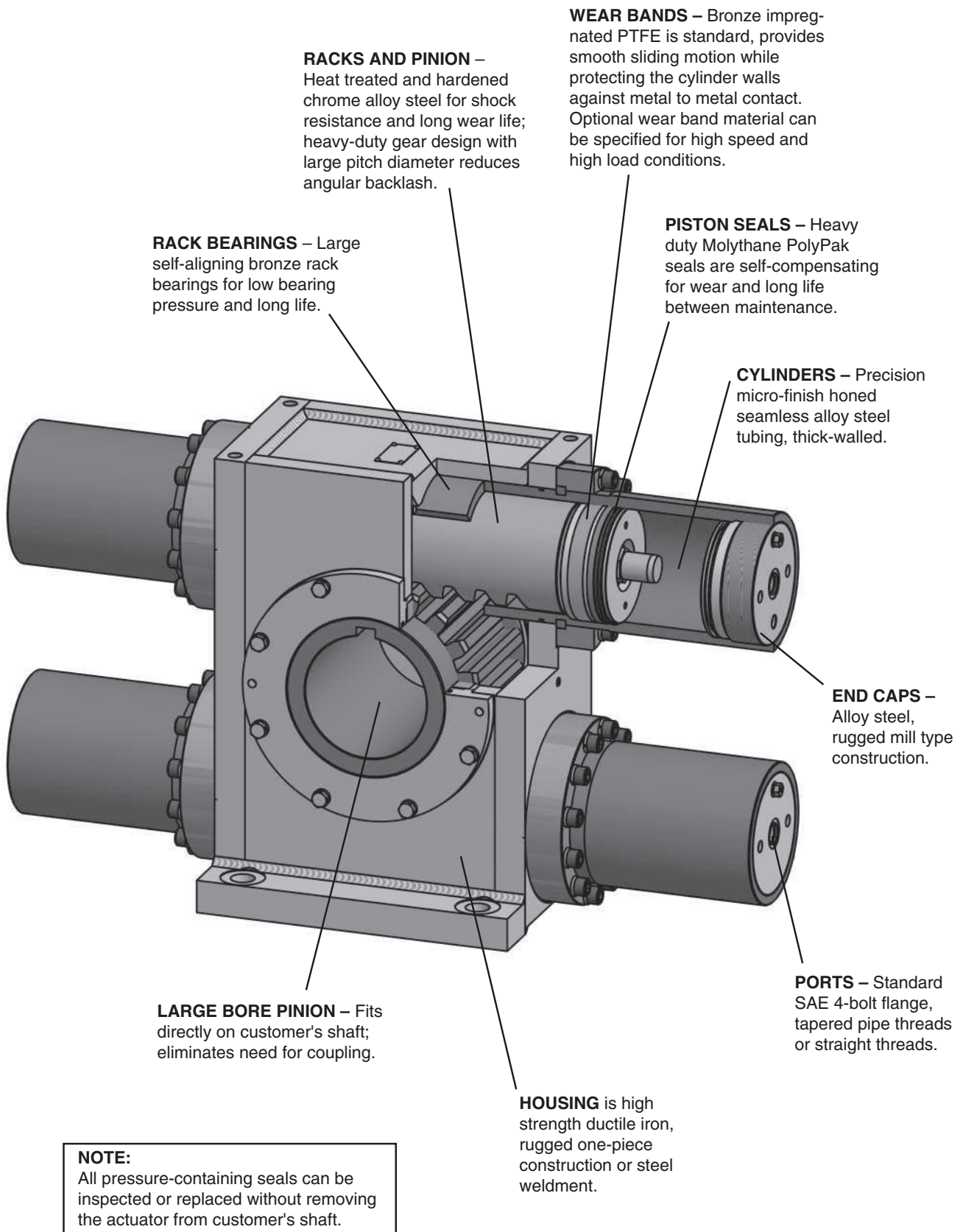

**Model Code and Ordering Information**

Example: 300M-0903C-LA2VG-B

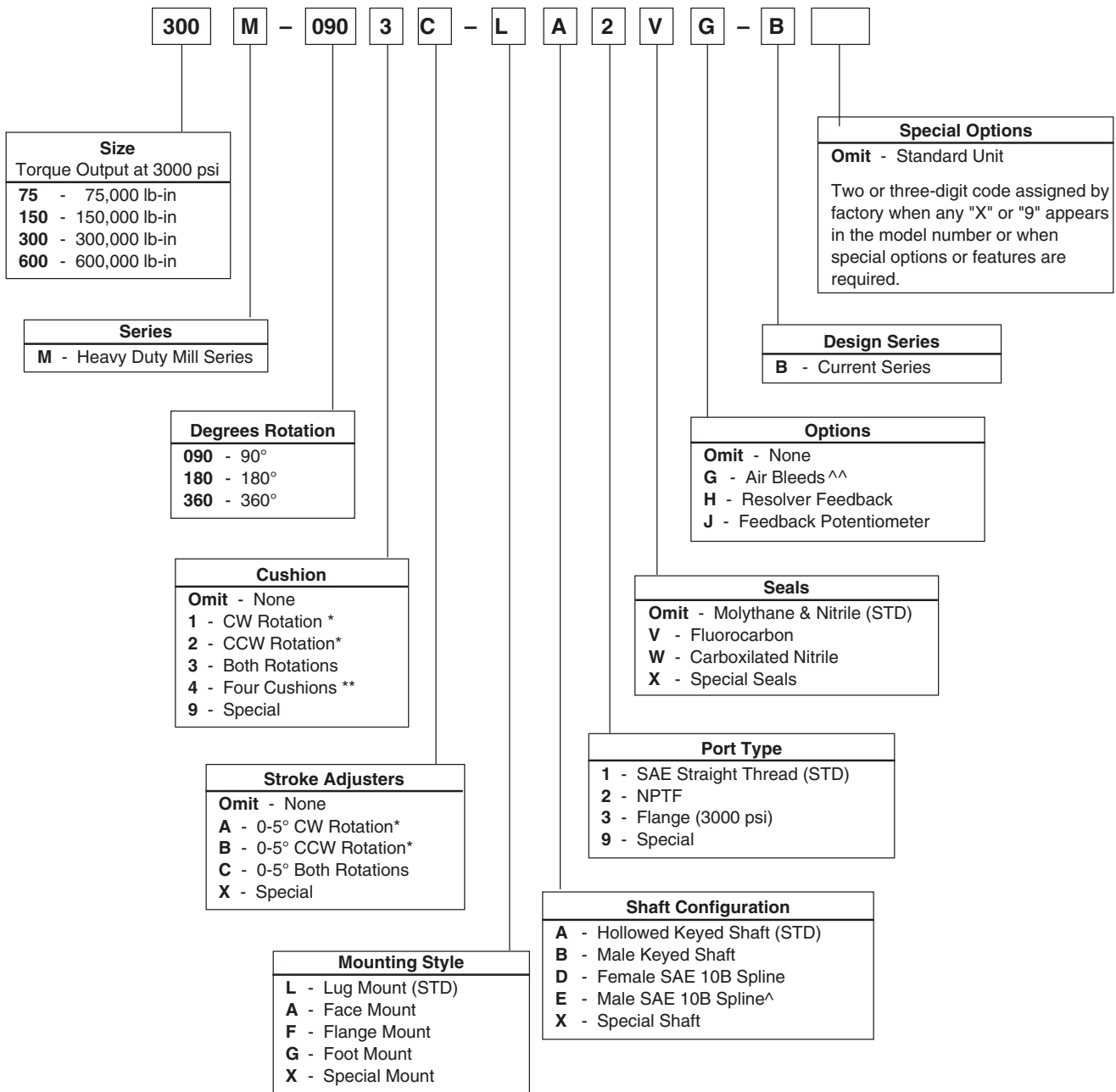

**Rack & Pinion Actuators**

LTR

HTR

M

\* Viewed from Shaft End  
\*\* Double Rack Models Only  
^ Not available with 300M or 600M actuators. A 39T involute spline shaft is available.  
^^ Std. on models larger than 1000M



### **M Series Heavy Duty Mill Rotary Actuator**

Designed to meet steel mill specifications. These non-tie rod units incorporate a range of features to provide heavy duty service dependability. The larger than normal heat treated pinions provide low tooth contact pressures and permit hollow shaft configurations with bore sizes capable of transmitting full operating torques, including shock loadings. In order to negate the chances of galling or scoring of the cylinder barrels, the Series M units are fitted with wear ring bushings that provide full support and eliminate the possibility of contact between cylinder and piston. The use of large diameter, tapered roller bearings on the pinion permit the actuator to absorb considerable thrust, radial and overhung loads. For ease of maintenance, all pressure seals on Series M can be inspected or replaced without removing the actuator from the customer's shaft. To ensure shipment of only the highest quality product, each actuator is fully tested and has an individual test sheet completed before final painting and shipment.

#### **SPECIFICATIONS**

- Maximum operating pressure: 3000 psi (207 Bar) hydraulic
- Standard rotations: 90°, 180°, 360°
- Rotational tolerances: -0°, +2°
- Output torques @ 3000 psi (207 Bar): 75,000 lb-in to 50,000,000 lb-in
- Maximum breakaway pressure: 75 psi (5 Bar)
- Operating temperature:
  - Standard nitrile seals -40° to 180°F (-40° to 82°C)
  - Fluorocarbon seals -20° to 250°F (-29° to 121°C)
- Mounting orientation: Unrestricted
- Timing: Keyway located at 12:00 position at midstroke of actuator
- Housing:
  - Heavy duty ductile iron (units up to 1000M),
  - steel weldments (units larger than 1000M)

Model		Maximum Pressure Rating, psi	Actual Output Torque, lb-in at Specified Pressure			Max. Angular Backlash (Minutes)	Standard Rotation Degrees	Displacement (Cubic Inches)	Standard Unit Weight (lb)
Single Rack	Double Rack		1000 psi (68 Bar)	2000 psi (136 Bar)	3000 psi (204 Bar)				
75M		3,000	25,000	50,000	75,000	15	90 180 360	43.4 86.9 174.0	202 217 259
	150M	3,000	50,000	100,000	150,000	15	90 180 360	86.9 174.0 347.0	301 331 415
300M		3,000	100,000	200,000	300,000	10	90 180 360	176.0 351.0 703.0	648 727 881
	600M	3,000	200,000	400,000	600,000	10	90 180 360	351.0 703.0 1,405.0	1033 1191 1499
	1,000M	3,000	333,000	667,000	1,000,000	10	90 180 360	556.0 1,112.0 2,224.0	1526 1774 2294
	1,500M	3,000	500,000	1,000,000	1,500,000	10	90 180 360	833.0 1,666.0 3,332.0	2100 2500 3300
	2,000M	3,000	667,000	1,333,000	2,000,000	10	90 180 360	1,248.0 2,496.0 4,992.0	3800 4480 5850
	3,000M	3,000	1,000,000	2,000,000	3,000,000	10	90 180 360	1,727.0 3,454.0 6,908.0	4900 5700 7300
	4,000M	3,000	1,333,000	2,667,000	4,000,000	10	90 180 360	2,389.0 4,778.0 9,556.0	Consult Factory
	5,000M	3,000	1,667,000	3,333,000	5,000,000	10	90 180 360	2,937.0 5,874.0 11,748.0	Consult Factory
	6,000M	3,000	2,000,000	4,000,000	6,000,000	10	90 180 360	3,552.0 7,104.0 14,208.0	Consult Factory
	7,000M	3,000	2,333,000	4,667,000	7,000,000	10	90 180 360	3,910.0 7,820.0 15,640.0	Consult Factory
	8,000M	3,000	2,667,000	5,333,000	8,000,000	10	90 180 360	4,640.0 9,280.0 18,560.0	Consult Factory
	9,000M	3,000	3,000,000	6,000,000	9,000,000	10	90 180 360	5,020.0 10,040.0 20,080.0	Consult Factory
	10,000M	3,000	3,333,000	6,667,000	10,000,000	10	90 180 360	5,840.0 11,680.0 23,360.0	Consult Factory
	15,000M	3,000	5,000,000	10,000,000	15,000,000	10	90 180 360	8,710.0 17,420.0 34,840.0	Consult Factory
	20,000M	3,000	6,667,000	13,333,000	20,000,000	10	90 180 360	11,476.0 22,952.0 45,904.0	Consult Factory
	25,000M	3,000	8,333,000	16,667,000	25,000,000	10	90 180 360	14,262.0 28,524.0 57,048.0	Consult Factory
	30,000M	3,000	10,000,000	20,000,000	30,000,000	10	90 180 360	17,815.0 35,630.0 71,260.0	Consult Factory
	40,000M	3,000	13,333,000	26,667,000	40,000,000	10	90 180 360	23,687.0 47,374.0 94,748.0	Consult Factory
	50,000M	3,000	16,667,000	33,333,000	50,000,000	10	90 180 360	27,369.0 54,738.0 109,476.0	Consult Factory

**Rack & Pinion Actuators**  
LTR  
HTR  
M



**Kinetic Energy Capacity**

The energy values below assume drive pressure is maintained through cushion stroke.

**Single Rack Units with Single Set of Cushions (20°)**

Model	Kinetic Energy Rating(in-lb) of Cushion at Specified Drive Pressure*													
	0 psi		500 psi		1000 psi		1500 psi		2000 psi		2500 psi		3000 psi	
	Max.	Durability	Max.	Durability	Max.	Durability	Max.	Durability	Max.	Durability	Max.	Durability	Max.	Durability
75M	26175	14245	21812	14245	17448	14245	13088	13088	8724	8724	4362	4362	0	0
300M	194700	54400	87247	54400	69793	54400	52350	52350	34897	34897	17449	17449	0	0

**Double Rack Units with Single Set of Cushions (20°)**

Model	Kinetic Energy Rating(in-lb) of Cushion at Specified Drive Pressure*													
	0 psi		500 psi		1000 psi		1500 psi		2000 psi		2500 psi		3000 psi	
	Max.	Durability	Max.	Durability	Max.	Durability	Max.	Durability	Max.	Durability	Max.	Durability	Max.	Durability
150M	26175	14245	17450	14245	8727	8727	0	0	0	0	0	0	0	0
600M	104700	54400	69801	54400	34907	34907	0	0	0	0	0	0	0	0
1000M	174500	97107	116336	97107	58178	58178	0	0	0	0	0	0	0	0

**Double Rack Units with Double Set of Cushions (20°) \*\***

Model	Kinetic Energy Rating(in-lb) of Cushion at Specified Drive Pressure*													
	0 psi		500 psi		1000 psi		1500 psi		2000 psi		2500 psi		3000 psi	
	Max.	Durability	Max.	Durability	Max.	Durability	Max.	Durability	Max.	Durability	Max.	Durability	Max.	Durability
150M	52350	30168	43623	30168	34879	30168	26175	26175	17448	17448	8725	8725	0	0
600M	209400	115216	174493	115216	139586	115216	104700	104700	69793	69793	34899	34899	0	0
1000M	349000	194215	290822	194215	232643	194215	174500	174500	116322	116322	58164	58164	0	0

\* Must deduct work (energy) done to overcome potential energy effects of load.  $W_{PE} = T_{PE} \times \theta$ , where  $\theta$  is in radians.

\*\* Extreme care must be exercised so that both cushions are adjusted equally for each direction or dangerous pressure intensification and gear train stresses could result. (Suggest high performance cushion option.)

**Cushion Deceleration Control**

The cushion causes the resisting torque that can be used to decelerate a rotational load. Please note the cushion has to provide enough resistance to control: drive torque caused by the hydraulic system pressure; plus the torque caused by gravity pulling on the rotational load; and the kinetic energy associated with the motion of the inertia load. Since the actuator's cushion has to be able to control the sum of all three torque factors, we suggest including cushion capacity as one of the actuator's selection criteria.

It is strongly suggested that proportional valves be used instead of cushions to control (decelerate) high inertial loads. This provides the ability to reduce inlet pressure while generating deceleration pressure. It also allows for longer ramp times, thus increasing deceleration stroke.

**SUPPLEMENTAL INFORMATION  
 KINETIC ENERGY BASIC FORMULA**

$$KE = 1/2 J_m \omega^2$$

$$\omega = 0.0175 \times \frac{2\Theta_A + \Theta_C + 2\Theta_D}{\text{Rotation Time (sec.)}}$$

where:

KE = Kinetic Energy (in-lb)

$J_m$  = Rotational Mass Moment of Inertia (in-lb-sec<sup>2</sup>)

$\omega$  = Peak Velocity (rad/sec)  
 (Assuming trapezoidal velocity profile)  
 See page 8 or the LTR Section for formulas.

$\Theta_A$  = Acceleration Angle (deg)

$\Theta_C$  = Constant Velocity Angle (deg)

$\Theta_D$  = Deceleration Angle (deg)





**Bearing Load Capacities**

Each M Series Actuator is fitted with heavy duty tapered roller bearings as standard and can support high external loads. The table provides load capacities for each unit.

Any distance "A" possible as long as bearing limits are observed. See overhung moment equation.

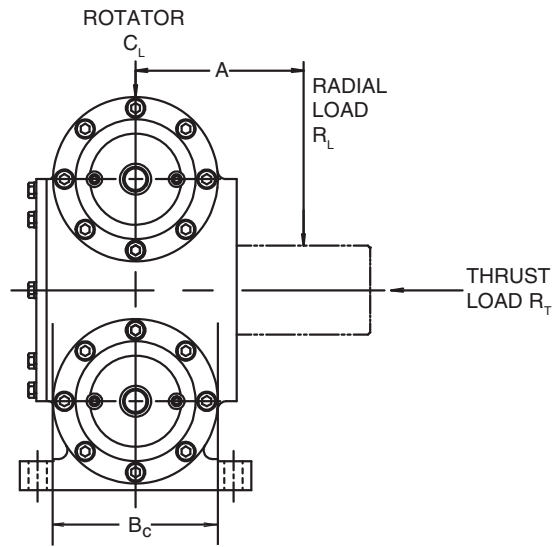

**Rack & Pinion Actuators**  
 LTR  
 HTR  
**M**

BEARING CAPACITIES "M" SERIES ROTATOR							
Model	Radial Load-lbs. Per Bearing ( $R_L$ )		Thrust Load-lbs. ( $R_T$ )		Bearing Center ( $B_c$ ) Distances Inch	Overhung Moment, Inch-lbs. $R_L \times (A + B_c/2)$	
	Dynamic	Static	Dynamic	Static		Dynamic	Static
75M	34,000	51,000	15,000	22,500	3.40	115,600	173,400
150M	42,000	63,000	15,000	22,500	3.40	142,800	214,200
300M	42,000	63,000	20,000	30,000	5.65	237,300	355,950
600M	57,000	85,500	20,000	30,000	5.65	322,050	493,075
1000M	50,000	75,000	20,000	30,000	7.40	370,000	555,000

**Unit Weights**

Model	Rotation					
	90°		180°		360°	
	lb	kg	lb	kg	lb	kg
75M	202	92	217	99	259	118
150M	301	137	331	150	415	188
300M	648	294	727	330	881	400
600M	1033	469	1191	541	1499	681
1000M	1526	693	1774	805	2294	1041
1500M	2100	953	2500	1135	3300	1498
2000M	3800	1725	4500	2043	5900	2679
3000M	4900	2225	5700	2588	7300	3314

**Single Rack with Standard Lug Mount (L) and Hollow Keyed Shaft (A)**

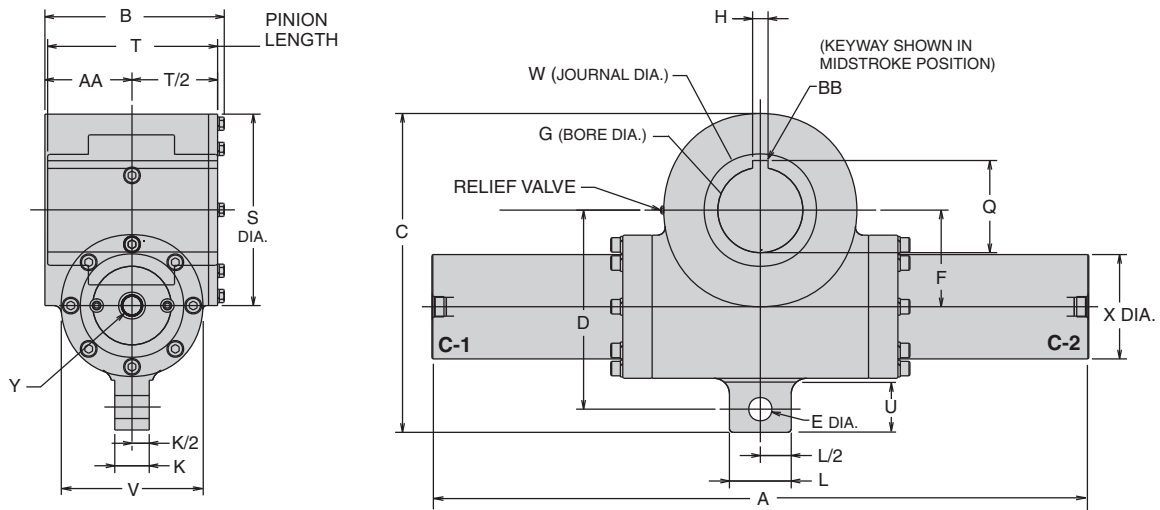

Model	Rotation Degrees	A	B	C (+.13, -.00)	D	E	F	G	K	L (+.13, -.00)	Q
75M	90	24.50	8.00	14.25	8.63	1.000	4.13	3.500 3.505	1.50	3.00	3.840
	180	34.50									
	360	55.50									
300M	90	34.25	11.88	20.63	12.88	1.500	6.25	5.500 5.505	2.25	4.00	5.960
	180	48.50									
	360	76.75									
Model	Rotation Degrees	H	S (+.13, -.00)	T	U	V (+.25, -.00)	W	X	Y	AA	BB
75M	90, 180, 360	.750	9.25	7.50	2.13	6.00	5.00	4.00	1 1/16-12 SAE #12	3.81	.030
		.753									
300M	90, 180, 360	1.000	12.50	11.25	3.25	9.25	7.25	6.75	1 5/16-12 SAE #16	5.96	.032
		1.003									

Note: All dimensions in inches unless otherwise specified.

**Double Rack with Standard Lug Mount (L) and Hollow Keyed Shaft (A)**

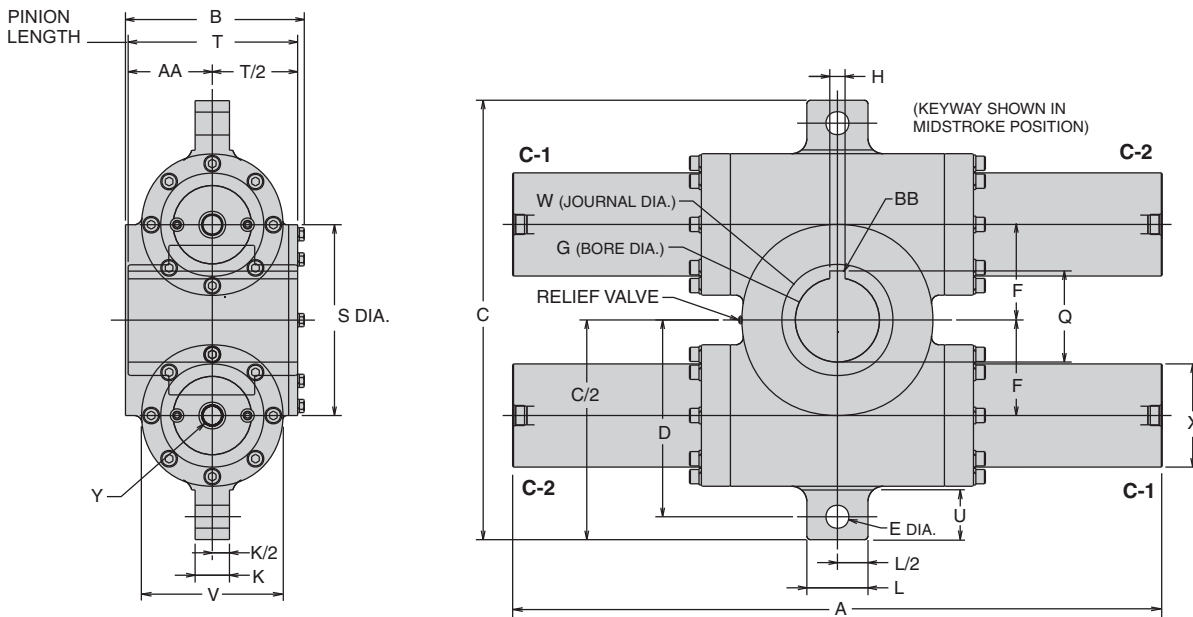

**Rack & Pinion Actuators**  
 LTR  
 HTR  
**M**

**Dimensions**

Sizes from 150 to 1000 lb-in

Model	Rotation Degrees	A	B	C (+.13, -.00)	D	E	F	G	H	K	L (+.13, -.00)	Q
150M	90	24.50	8.00	19.25	8.63	1.000	4.13	3.500 3.505	0.750 0.753	1.50	3.00	3.840
	180	34.50										
	360	55.50										
600M	90	34.25	11.88	28.75	12.88	1.500	6.25	5.500 5.505	1.000 1.003	2.25	4.00	5.960
	180	48.50										
	360	76.75										
1000M	90	40.25	13.88	32.50	14.75	1.500	7.25	7.250 7.255	1.000 1.002	2.25	4.00	7.725
	180	57.00										
	360	90.50										
Model	Rotation Degrees	S (+.13, -.00)	T	U	V (+.25, -.00)	W	X	Y	AA	BB		
150M	90, 180, 360	9.25	7.50	2.13	6.00	5.00	4.00	1 1/16-12 SAE #12	3.81	0.030		
600M	90, 180, 360	12.50	11.25	3.25	9.25	7.25	6.75	1 5/16-12 SAE #16	5.69	0.032		
1000M	90, 180, 360	14.50	12.00	3.25	10.25	9.13	7.75	1 5/16-12 SAE #16	6.75	0.060		

Note: All dimensions in inches unless otherwise specified.

1800\_MSeries.pmd, M&A



**Double Rack with Standard Lug Mount (L) and Hollow Keyed Shaft (A)**

**Dimensions\*  
Sizes from 1500 to 50000 lb-in**

Model	Rotation Degrees	A	B	C	D	E	F	G	H	K
1,500M	90	44	16 <sup>1</sup> / <sub>2</sub>	35	16	1 <sup>1</sup> / <sub>2</sub>	8 <sup>1</sup> / <sub>4</sub>	8	1 <sup>1</sup> / <sub>4</sub>	2 <sup>1</sup> / <sub>4</sub>
	180	62							x	
	360	101 <sup>1</sup> / <sub>2</sub>							13 <sup>1</sup> / <sub>2</sub>	
2,000M	90	48	19	41 <sup>1</sup> / <sub>4</sub>	18 <sup>7</sup> / <sub>8</sub>	1 <sup>3</sup> / <sub>4</sub>	9 <sup>3</sup> / <sub>8</sub>	9 <sup>1</sup> / <sub>2</sub>	1 <sup>1</sup> / <sub>2</sub>	2 <sup>1</sup> / <sub>4</sub>
	180	70							x	
	360	114							14 <sup>1</sup> / <sub>2</sub>	
3,000M	90	48 <sup>1</sup> / <sub>2</sub>	21	45 <sup>3</sup> / <sub>4</sub>	20 <sup>7</sup> / <sub>8</sub>	2	10 <sup>1</sup> / <sub>8</sub>	9 <sup>3</sup> / <sub>4</sub>	1(2)	3
	180	70 <sup>1</sup> / <sub>2</sub>							x	
	360	114 <sup>1</sup> / <sub>2</sub>							16	
4,000M	90	54	23 <sup>1</sup> / <sub>2</sub>	51 <sup>1</sup> / <sub>4</sub>	23 <sup>3</sup> / <sub>8</sub>	2 <sup>1</sup> / <sub>4</sub>	11 <sup>3</sup> / <sub>8</sub>	11 <sup>1</sup> / <sub>4</sub>	1 <sup>1</sup> / <sub>2</sub>	3 <sup>1</sup> / <sub>2</sub>
	180	79							x	
	360	129							18 <sup>1</sup> / <sub>2</sub>	
5,000M	90	55	25	54 <sup>3</sup> / <sub>4</sub>	25 <sup>1</sup> / <sub>8</sub>	2 <sup>1</sup> / <sub>4</sub>	12 <sup>5</sup> / <sub>8</sub>	12 <sup>1</sup> / <sub>2</sub>	1 <sup>1</sup> / <sub>2</sub>	3 <sup>1</sup> / <sub>2</sub>
	180	80 <sup>1</sup> / <sub>2</sub>							x	
	360	130 <sup>1</sup> / <sub>2</sub>							18 <sup>1</sup> / <sub>2</sub>	
6,000M	90	63 <sup>1</sup> / <sub>2</sub>	25 <sup>1</sup> / <sub>2</sub>	57 <sup>1</sup> / <sub>2</sub>	26 <sup>1</sup> / <sub>4</sub>	2 <sup>1</sup> / <sub>2</sub>	13	13 <sup>1</sup> / <sub>2</sub>	1 <sup>3</sup> / <sub>4</sub>	3 <sup>3</sup> / <sub>4</sub>
	180	95							x	
	360	158							21 <sup>1</sup> / <sub>2</sub>	
7,000M	90	74 <sup>1</sup> / <sub>2</sub>	26 <sup>1</sup> / <sub>2</sub>	61 <sup>1</sup> / <sub>2</sub>	28	2 <sup>3</sup> / <sub>4</sub>	14	15	2	4
	180	109 <sup>1</sup> / <sub>2</sub>							x	
	360	179							22	
8,000M	90	76	26 <sup>1</sup> / <sub>2</sub>	63 <sup>3</sup> / <sub>4</sub>	29 <sup>1</sup> / <sub>4</sub>	2 <sup>3</sup> / <sub>4</sub>	15	16	2 <sup>1</sup> / <sub>4</sub>	4
	180	114							x	
	360	190							22	
9,000M	90	80	26 <sup>1</sup> / <sub>2</sub>	67	30 <sup>1</sup> / <sub>2</sub>	3	16	18	2 <sup>1</sup> / <sub>2</sub>	4 <sup>1</sup> / <sub>2</sub>
	180	121							x	
	360	203							18 <sup>1</sup> / <sub>2</sub>	
10,000M	90	85	28	69	31 <sup>1</sup> / <sub>2</sub>	3	17	20	2 <sup>1</sup> / <sub>2</sub>	4 <sup>1</sup> / <sub>2</sub>
	180	129							x	
	360	217							22	
15,000M	90	102	28	82	37 <sup>1</sup> / <sub>2</sub>	3 <sup>1</sup> / <sub>2</sub>	21 <sup>1</sup> / <sub>2</sub>	22	2 <sup>1</sup> / <sub>2</sub>	5
	180	159							x	
	360	272							22	
20,000M	90	110	29	87	39 <sup>1</sup> / <sub>2</sub>	4	23 <sup>1</sup> / <sub>2</sub>	31	2 <sup>1</sup> / <sub>2</sub> (2)	5
	180	173							x	
	360	298 <sup>1</sup> / <sub>2</sub>							22	
25,000M	90	110	30 <sup>1</sup> / <sub>2</sub>	95	42 <sup>1</sup> / <sub>2</sub>	5	24 <sup>1</sup> / <sub>2</sub>	31	2 <sup>1</sup> / <sub>2</sub> (2)	5
	180	173							x	
	360	298 <sup>1</sup> / <sub>2</sub>							26	
30,000M	90	112	32 <sup>1</sup> / <sub>2</sub>	98	44	5	25	31	2 <sup>1</sup> / <sub>2</sub> (2)	5
	180	175							x	
	360	300 <sup>1</sup> / <sub>2</sub>							28	
40,000M	90	132	36	108	49	5	28 <sup>1</sup> / <sub>2</sub>	38	3(2)	6
	180	207 <sup>1</sup> / <sub>2</sub>							x	
	360	358							30	
50,000M	90	133	37	111	50 <sup>1</sup> / <sub>2</sub>	5	29 <sup>1</sup> / <sub>4</sub>	38	3(2)	6
	180	209							x	
	360	359 <sup>1</sup> / <sub>2</sub>							32	

\* Units 1500M and above have dimensions that are subject to change. Consult factory on these dimensions before any design implementation is initiated.

Note: All dimensions in inches unless otherwise specified.



### Cushions (1, 2, 3, 4)

The standard cushions operate over the last 20° of rotation in either or both directions. A floating bushing ensures no binding of cushion spear. For severe operating conditions, 4 cushions should be fitted on double rack units.

All cushions are fully adjustable. Double rack units should be fitted with Type 4 cushions.

**NOTE:** Proportional valves are recommended instead of cushions for high inertial loads.

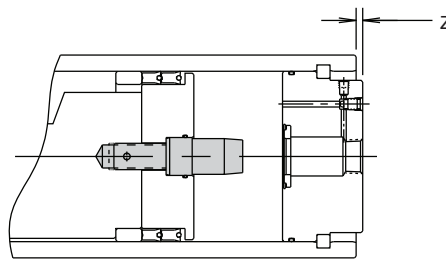

Model	Z
75M	.50
150M	.50
300M	.25
600M	.25
1000M	.00

Cushion Kinetic Energy Capacity				
Model	Cushion Code	Dissipation (Inch lbf)	Cushion Code	Cushion Work (in-lb)
75M	3	27,630	1,2	27,165
150M	4	55,300	1,2,3	27,165*
300M	3	84,190	1,2	104,700
600M	4	168,370	1,2,3	104,700*
1,000M	4	192,000	1,2,3	192,000*

\* Must deduct work done by any existing drive pressure and work done to control potential energy.

### 5° Stroke Adjusters (A, B, C)

Model	(1) Turn Adj.
75M 150M	1°
300M 600M	8°
1000M	7°

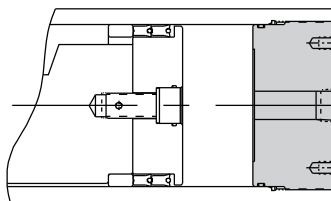

**NOTE:**

- Maximum unit rotation is equal to rotation specified in model code. Adjusters allow rotational positioning equal to or less than the maximum rotation.
- Stroke adjusters are available with or without cushions. Double rack units will have cushions and stroke adjusters on lower rack.

Note: All dimensions in inches unless otherwise specified.

**Face Mounting (A)**

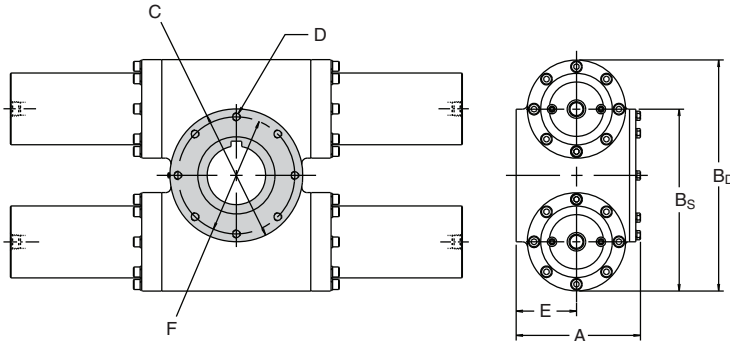

Model	Torque lb-in @ 3,000 psi	A	B <sub>s</sub>	B <sub>D</sub>	C	D	E	F
75M	75,000	8	11.75	N/A	9.25	5/8-18 x 15/16 DP	3.81	8.000
150M	150,000	8	N/A	14.25	9.25	5/8-18 x 15/16 DP	3.81	8.000
300M	300,000	11-7/8	17.13	N/A	12.50	3/4-16 x 1-1/8 DP	5.69	11.000
600M	600,000	11-7/8	N/A	21.75	12.50	3/4-16 x 1-1/8 DP	5.69	11.000
1,000M	1,000,000	13-5/8	N/A	24.75	14.50	1-1/4-12 x 1-7/8 DP	6.75	12.000

**Face Mounting Bi-directional Torque Capacity**  
(without dowel devices)

Model	Bolt Size	Suggested Bolt Torque (lb - ft)	Bi-Directional Torque Capacity* (lb - in)
75M	5/8-18 x 15/16 dp	100	105,495
150M	5/8-18 x 15/16 dp	100	105,495
300M	3/4-16 x 1-1/8 dp	160	167,200
600M	3/4-16 x 1-1/8 dp	160	167,200
1,000M	1-1/4-12 x 1-7/8 dp	720	496,800

\* With additional reinforcement.

Bi-directional bolt torque capacity is equal to:

$$\mu \times \text{clamp load} \times \text{lever arm length from center of rotation}$$

( $\mu = .3$  assumed).

**Suggested Reinforcement**

Model	Dowel Ø	Qty.	Bolt Circle Diameter
150M	.75	2	8
300M	.75	4	11
600M	1.00	4	11
1,000M	1.00	8	12

Note: All dimensions in inches unless otherwise specified.

**Flange Mounting (F)**

In addition to the flange shown, made to order sizes can be manufactured.

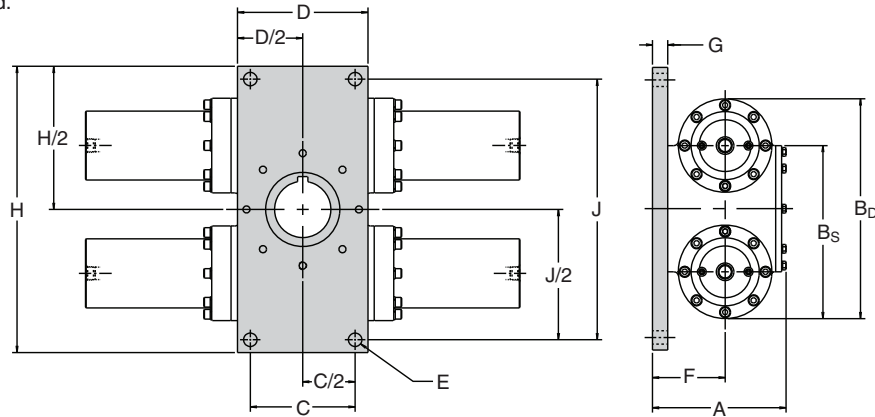

Model	Torque lb-in @ 3000 psi	A	B <sub>S</sub>	B <sub>D</sub>	C	D	E	F	G	H	J
75M	75,000	9-1/4	11.75	N/A	7.500	9.500	1.063	5.06	1.25	19.25	17.250
150M	*	9-1/4	N/A	14.25	7.500	9.500	1.063	5.06	1.25	19.25	17.250
300M	*	13-3/8	17.13	N/A	10.250	12.750	1.313	7.19	1.50	28.00	25.500
600M	*	13-3/8	N/A	21.75	10.250	12.750	1.313	7.19	1.50	28.00	25.500
1,000M	*	15-3/8	N/A	24.75	11.500	16.750	1.563	8.50	1.75	32.25	29.250

\* Consult factory with applications data.

**Foot Mounting (G)**

The foot is an integral part of the housing, machined on all sides to accommodate shear block mounting. (1,000M & smaller).

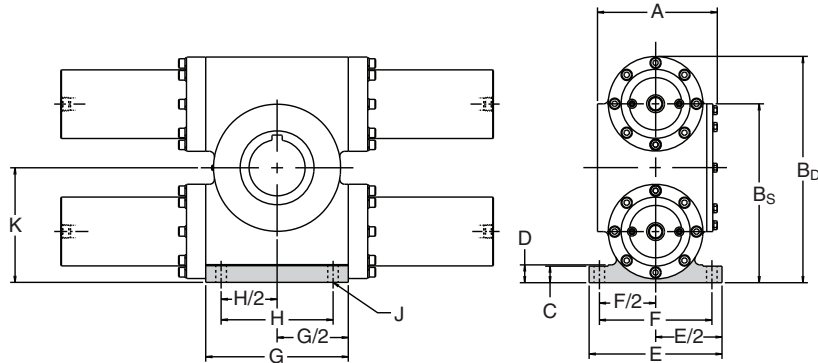

Model	Torque lb-in @ 3000 psi	A	B <sub>S</sub>	B <sub>D</sub>	C	D	E	F	G	H	J	K
75M	75,000	8	12.00	N/A	1.38	1.50	11.00	9.500	10.00	7.500	.781	7.375 +0.005 -0.000
150M	150,000	8	N/A	14.50	1.38	1.50	11.00	9.500	10.00	7.500	.781	
300M	300,000	11-7/8	17.50	N/A	1.63	1.75	13.00	11.000	14.00	11.000	1.031	11.250 +0.005 -0.000
600M	600,000	11-7/8	N/A	22.13	1.63	1.75	13.00	11.000	14.00	11.000	1.031	
1,000M	1,000,000	13-7/8	N/A	25.13	1.88	2.00	16.00	13.500	16.75	13.500	1.281	12.750 +0.000 -0.005

Note: All dimensions in inches unless otherwise specified.

**Options**

**Shaft Options (B, D, E)**

All shaft options shown in mid-stroke position.

**Male Keyed Shaft (B)**

Model	A	B	C	D	E	Torque Rating
75M 150M	.749 .750	4.50	3.000 2.999	2.577 2.572	3.38	102,000 lb-in
300M 600M	1.249 1.250	7.50	5.000 4.999	4.297 4.292	6.00	475,000 lb-in
1000M	2.000 2.002	12.00	8.000 7.999	6.873 6.868	10.00	1,000,000 lb-in

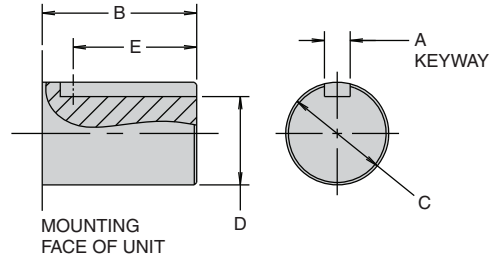

Suggested Key Materials			
Model	A	E	Material
75M 150M	0.750/0.749	3.38	C1018 CR
300M 600M	1.250/1.249	6	C1018 CR
1000M	1.250/1.249	6	C1018 CR

**Female SAE 10B Spline (D)**

Model	A	B	C	D	E	F
75M 150M	3.03	3.00	3.000 2.998	2.580 2.578	0.468 0.465	4.999 4.997
300M 600M 1000M	39T, 30° involute splined shaft is available. Consult factory.					

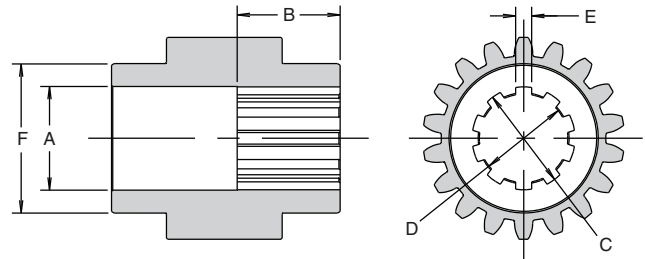

**Male SAE 10B Spline (E)**

Model	A	B	C	D	E
75M 150M	4.50	2.88	2.997 2.995	2.573 2.568	0.464 0.463
300M 600M 1000M	39T, 30° involute splined shaft is available. Consult factory.				

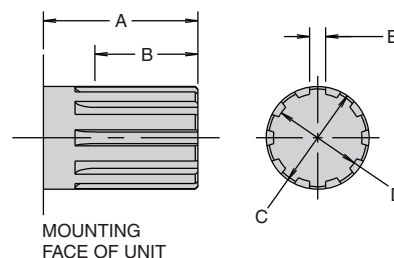

Note: All dimensions in inches unless otherwise specified.



**Ports (1, 2, 3)**

SAE straight thread ports or 4 bolt flanges are recommended for all applications. NPT ports are available but not recommended.

Model	Standard SAE Straight Thread (1)	NPT (2)	4 Bolt Flange (3) SAE J518 (3000 psi)
75M 150M	1-1/16 -12 (SAE 12)	3/4	3/4
300M 600M	1-5/16 -12 (SAE 16)	1	1
1000M	1-5/16-12 (SAE 16)	1	1

**Seals (V, W)**

Seal Class	Seal Type	Wear Ring Type	Fluid Medium	Temperature Range	Filtration
Standard	Molythane PolyPak	Filled PTFE	General purpose, petroleum-based fluids	-40°F to 180°F -40°C to 82°C	ISO Class 17/14 Cleanliness Level
Viton (V)	Fluorocarbon	Filled PTFE	High Temperature and/or Synthetic Fluids	-20°F to 250°F -29°C to 121°C	
Nitrile (W)	Carboxylated Nitrile*	Filled PTFE	Water Glycol, High Water Content Fluids	30°F to 180°F 0°C to 82°C	

\* Not available in every size. Factory will automatically make appropriate substitutions as necessary.

***For Seal Kits and Spare Parts, contact the Pneumatic Division at 330-336-3511.***

**Feedback Packages**

Feedback packages available for use with M Series rotary actuators include:

- Precision feedback potentiometer (J)
- Precision resolver feedback (H)
- Linear potentiometer feedback (Oilydne Teknar)
- LDT feedback (MTS Temposonics)

The feedback potentiometer (J) and resolver feedback (H) may be ordered as part of the model code. The other options must be ordered separately.

See Sensors section for specifications.

**Rack & Pinion Actuators**  
LTR  
HTR  
M





# HRN/HRN-C Series

## Hydraulic Vane Rotary Actuators

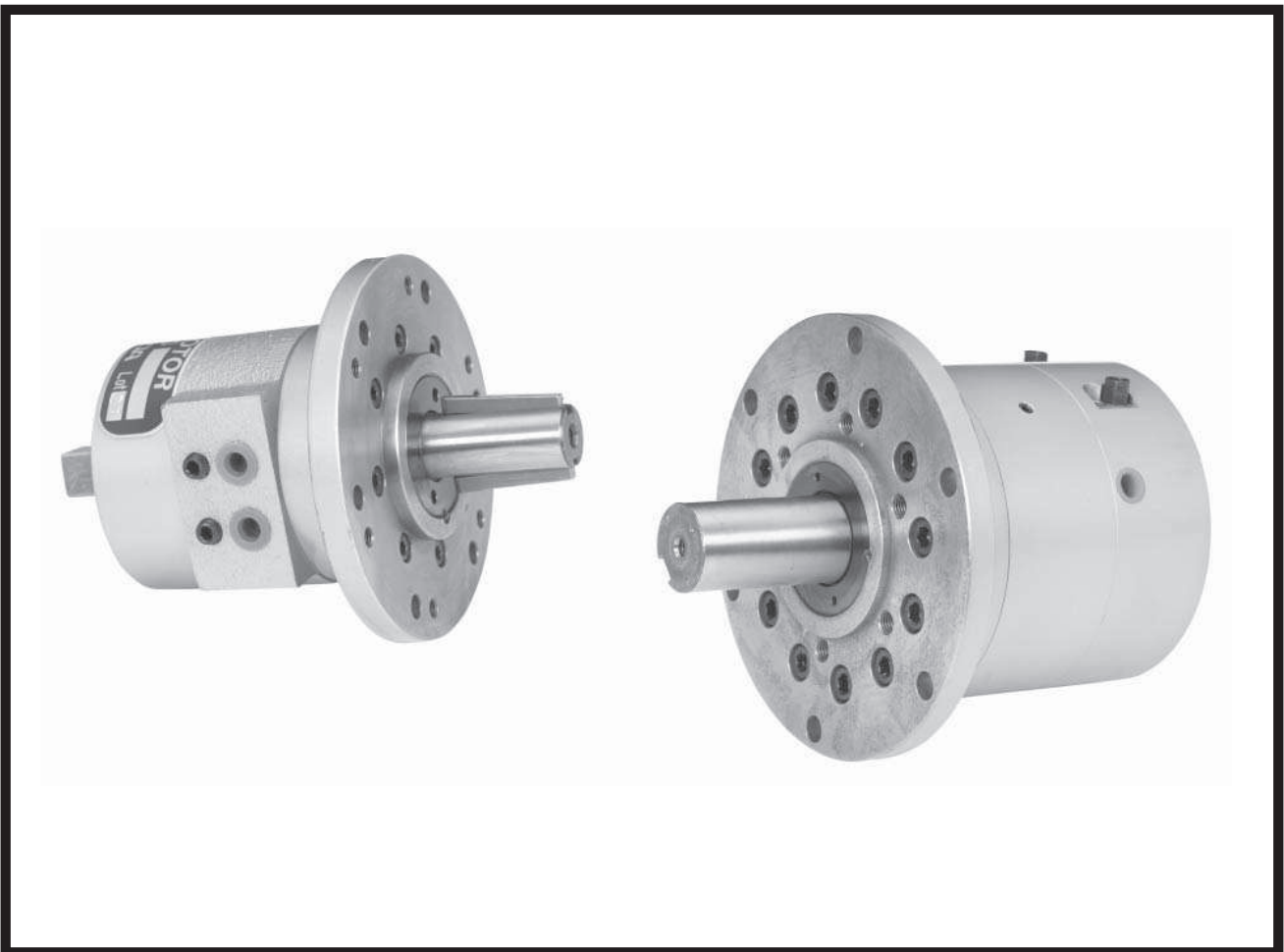

Vane Actuators

HRN

Tork-Mor

### Contents

#### HRN Series

Features .....	2
Ordering Information .....	4
Engineering Data / Specifications .....	5
Dimensions .....	6

#### HRN-C Series

Features .....	10
Ordering Information .....	12
Engineering Data/Specifications .....	13
Dimensions .....	15
Keys .....	18



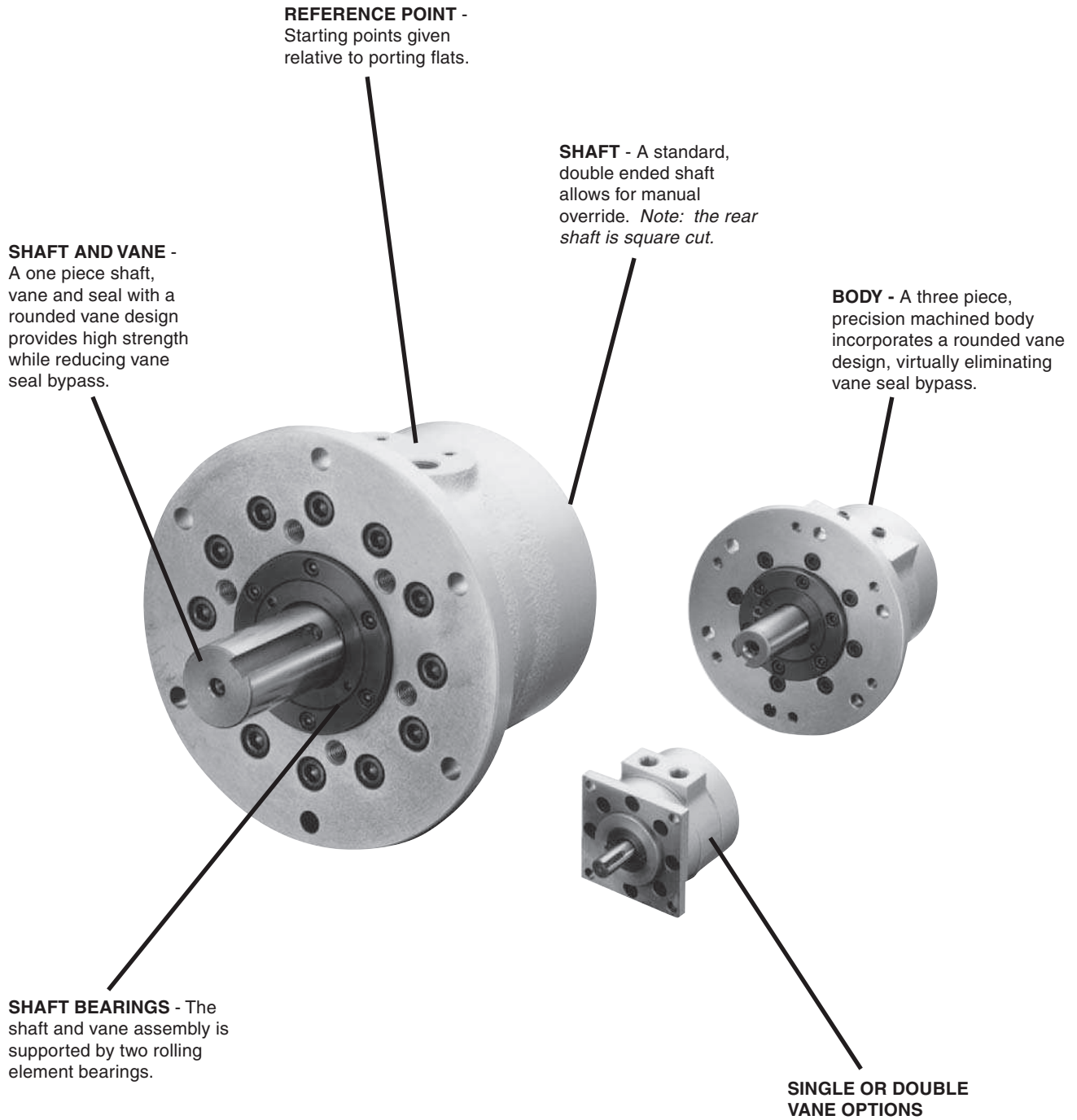

**HRN Series**

The HRN Series incorporates a rounded vane design, which provides lower vane seal bypass. The shaft and vane are machined from high strength alloy steel as one piece. The vane seal is molded in a pre-machined groove in order to provide a one piece shaft, vane, and seal assembly for long life and reliability. The standard rear output shaft provides for an easily accessible manual override in the event that hydraulic pressure is lost.

Available options include rotations of 90 degrees and 270 degrees depending on whether the unit is arranged as a double vane or single vane configuration. Reference points (or keyway timing) are provided relative to the port positioning. Large, convenient, front flange with precision pilot diameter allows for concise mounting and easy integration with the customer's application.

**Specifications**

- Rated Operating Pressure: 7 MPa (1000 psi)
- Minimum Operating Pressure: 1 MPa (145 psi)
- Output Torque @ 7 MPa: 10 to 1960 N•m (89 to 17346 in-lb)
- Standard Rotations: 90° to 270°
- Operating Temperature Range: 0°C to 60°C (32°F to 140°F)
- Filtration Requirement: ISO Class 17/14 Cleanliness Level
- Mounting Orientation: Unrestricted
- Standard Keyway Timing: See Figures for Start Position

**Quick Reference Data**

Model Number		Theoretical Output Torque				Maximum Breakaway Pressure	Unit Weight
		1.75 MPa (250 psi)	3.50 MPa (500 psi)	5.00 MPa (750 psi)	7.00 MPa (1000 psi)		
		N•m (in-lb)	N•m (in-lb)	N•m (in-lb)	N•m (in-lb)	MPa (psi)	kg (lb)
Single Vane	HRN10S	2 (17.7)	4 (35.0)	8 (70.8)	10 (89.0)	1.00 (145)	1.00 (2.21)
	HRN15S	3 (26.6)	8 (70.8)	12 (106.0)	20 (177.0)	1.00 (145)	2.00 (4.41)
	HRN20S	9 (79.7)	13 (115.0)	19 (168.0)	30 (266.0)	1.00 (145)	3.00 (6.62)
	HRN30S	12 (106.2)	21 (186.0)	45 (398.0)	60 (531.0)	1.00 (145)	4.30 (9.48)
	HRN100S	20 (177.0)	55 (487.0)	96 (850.0)	123 (1089.0)	1.00 (145)	10.20 (22.49)
	HRN200S	40 (354.0)	133 (1177.0)	210 (1859.0)	314 (2779.0)	1.00 (145)	20.00 (44.10)
	HRN400S	100 (885.0)	200 (1770.0)	420 (3717.0)	539 (4770.0)	1.00 (145)	32.00 (70.56)
	HRN700S	170 (1504.5)	211 (1867.0)	397 (3513.0)	980 (8673.0)	1.00 (145)	41.00 (90.41)
Double Vane	HRN10D	3 (26.6)	8 (70.8)	12 (106.2)	20 (177.0)	1.00 (145)	1.00 (2.21)
	HRN15D	6 (53.1)	18 (142.0)	27 (239.0)	40 (354.0)	1.00 (145)	2.00 (4.41)
	HRN20D	12 (106.2)	21 (186.0)	45 (398.0)	60 (531.0)	1.00 (145)	3.00 (6.62)
	HRN30D	21 (185.9)	49 (434.0)	78 (690.0)	117 (1035.0)	1.00 (145)	4.50 (9.92)
	HRN100D	30 (265.5)	105 (929.0)	160 (1416.0)	245 (2168.0)	1.00 (145)	10.40 (22.93)
	HRN200D	71 (628.4)	250 (2213.0)	405 (3584.0)	627 (5549.0)	1.00 (145)	20.50 (45.20)
	HRN400D	220 (1947.0)	440 (3894.0)	760 (6726.0)	1078 (9540.0)	1.00 (145)	33.00 (72.77)
	HRN700D	320 (2832.0)	730 (6461.0)	1132 (10018.0)	1960 (17346.0)	1.00 (145)	43.00 (94.82)

**Model Code and Ordering Information**

Example: HRN100S

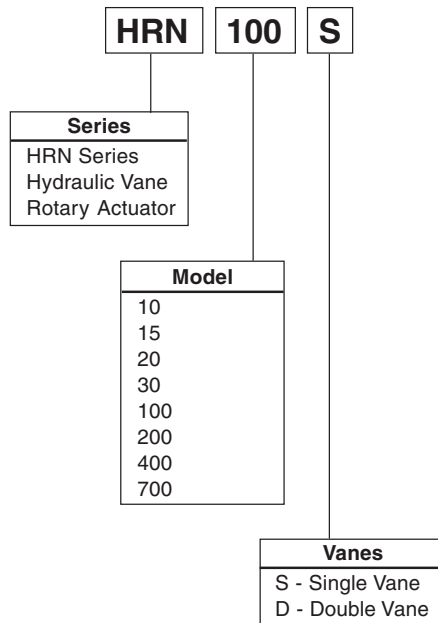

**Oscillation Starting Point**

**HRN10S, HRN15S, HRN20S,  
 HRN30S, HRN100S, HRN200S,  
 HRN400S, HRN700S**

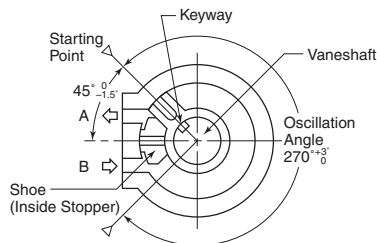

Note:  
 1. Figures show stroke end position with B port pressurized.  
 2. It is a view from shaft-with-key side.

**HRN10D, HRN15D, HRN20D,  
 HRN30D, HRN100D, HRN200D,  
 HRN400D, HRN700D**

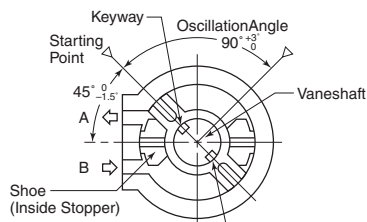

Two Keyways are provided for HRN-30D, 100D and 200D types only

Model No.	Unit Size	HRN10S	HRN15S	HRN20S	HRN30S	HRN100S	HRN200S	HRN400S	HRN700S
Vane		Single Vane							
Rotation	Degree	270							
Rotational Tolerance	Degree	+3 -0							
Reference Point	Degree	45							
Port Size		Rc 1/8			Rc 1/4	Rc 3/8		Rc 1/2	
Minimum Operating Pressure Range	MPa	1.0							
	psi	145.0							
Maximum Operating Pressure Range	MPa	7.0							
	psi	1015.0							
Fluid Temperature Range	°C	0 to 60							
	°F	32 to 140							
Displacement	cm <sup>3</sup>	10.0	17.0	24.0	51.0	111.0	221.0	435.0	780.0
Internal Bypass Leakage at 40°C	cm <sup>3</sup> /min	10.0	15.0	20.0	30.0	50.0	100.0	100.0	100.0

Model No.	Unit Size	HRN10D	HRN15D	HRN20D	HRN30D	HRN100D	HRN200D	HRN400D	HRN700D
Vane		Double Vane							
Rotation	Degree	90							
Rotational Tolerance	Degree	+3 -0							
Reference Point	Degree	45							
Port Size		Rc 1/8			Rc 1/4	Rc 3/8		Rc 1/2	
Minimum Operating Pressure Range	MPa	1.0							
	psi	145.0							
Maximum Operating Pressure Range	MPa	7.0							
	psi	1015.0							
Fluid Temperature Range	°C	0 to 60							
	°F	32 to 140							
Displacement	cm <sup>3</sup>	6.5	11.0	16.0	34.0	74.0	147.0	290.0	520.0
Internal Bypass Leakage at 40°C	cm <sup>3</sup> /min	20.0	30.0	40.0	60.0	100.0	200.0	200.0	200.0

**Vane Actuators**  
HRN  
Tork-Mor

**Kinetic Energy Ratings and Bearing Load Capacities**

Model Number	Bearing Load Capacities				Maximum Inertia Energy Rating	
	Thrust Load		Radial Load		J	in-lb
	N	lb	N	lb		
HRN10	4.9	1.1	9.8	2.2	0.013	0.12
HRN15	9.8	2.2	19.6	4.4	0.025	0.22
HRN20	24.5	5.5	49	11.0	0.046	0.41
HRN30	39.2	8.8	78.4	17.6	0.088	0.78
HRN100	68.6	15.4	147.0	33.0	0.255	2.26
HRN200	137.2	30.8	294.0	66.1	0.510	4.51
HRN400	166.6	37.5	343.0	77.1	0.755	6.68
HRN700	166.6	37.5	343.0	77.1	0.911	8.06

Note: The allowable inertia energy is applicable when the load is installed on the keyed input shaft.

**Caution: Operation of actuator at conditions of excessive inertia energy may damage the actuator. See Engineering Guidelines section for selection criteria.**



**HRN10S/D**

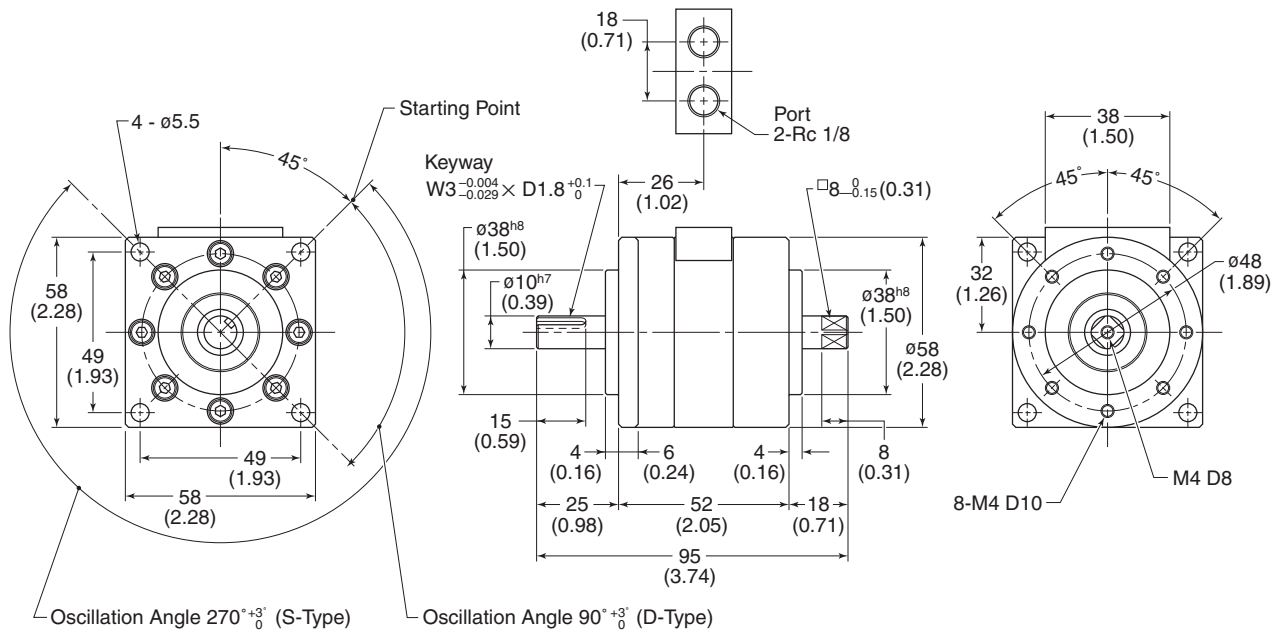

**HRN15S/D**

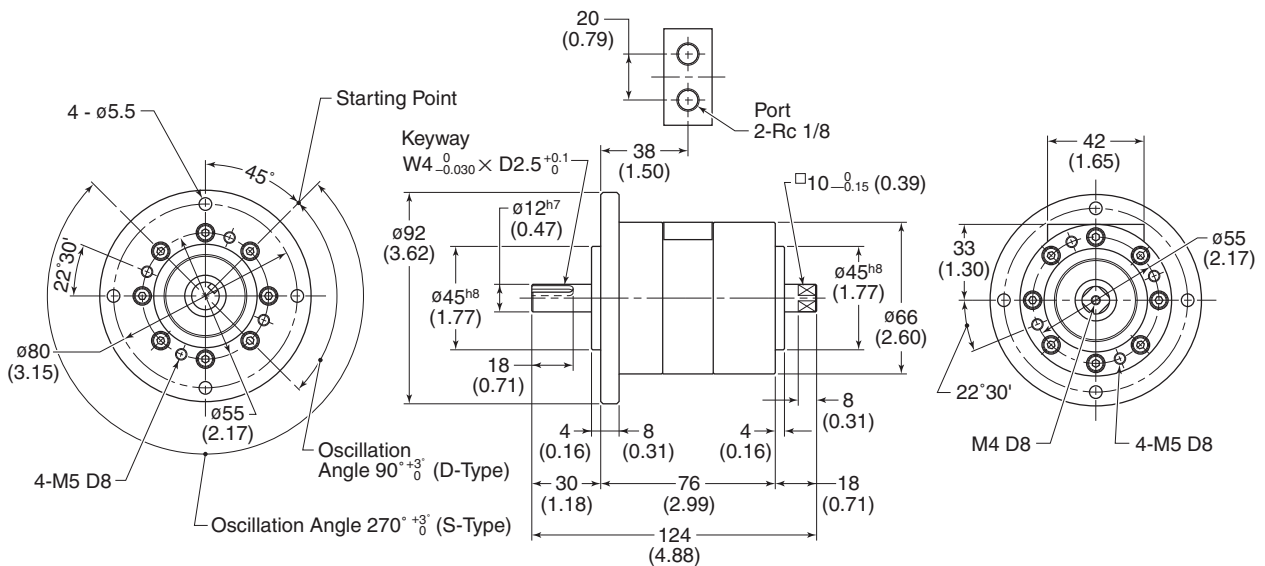

Dimensions are in mm (Inches)



**HRN20S/D**

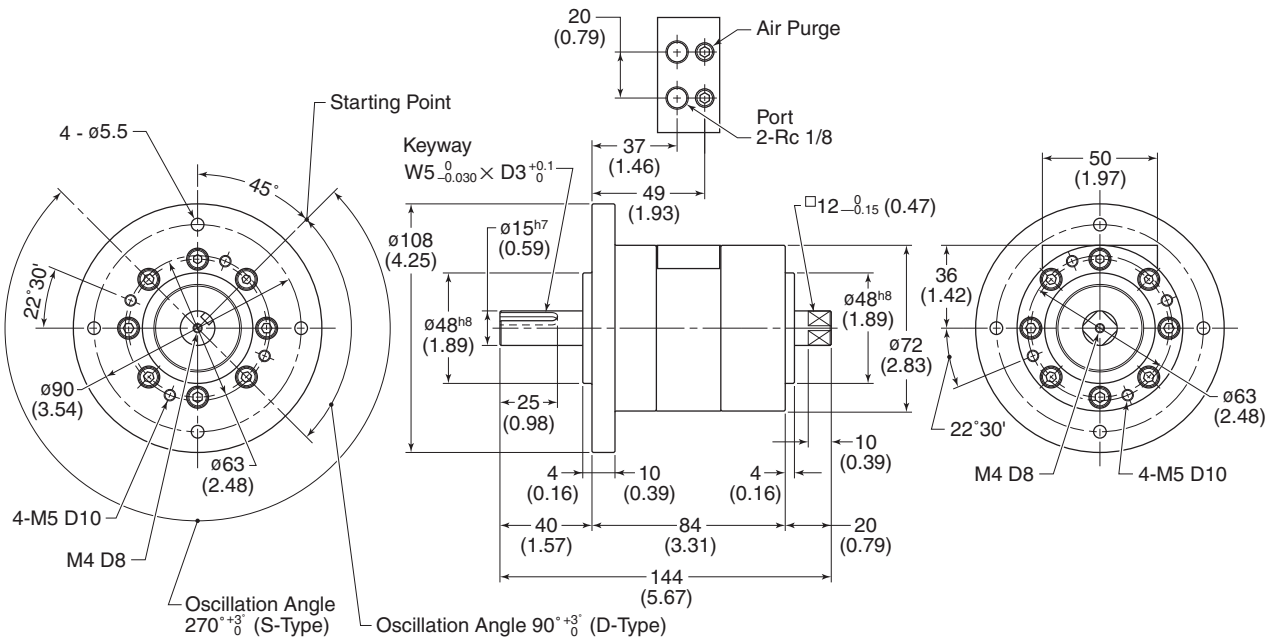

**Vane Actuators**  
**HRN**  
 Torq-Mor

**HRN30S/D**

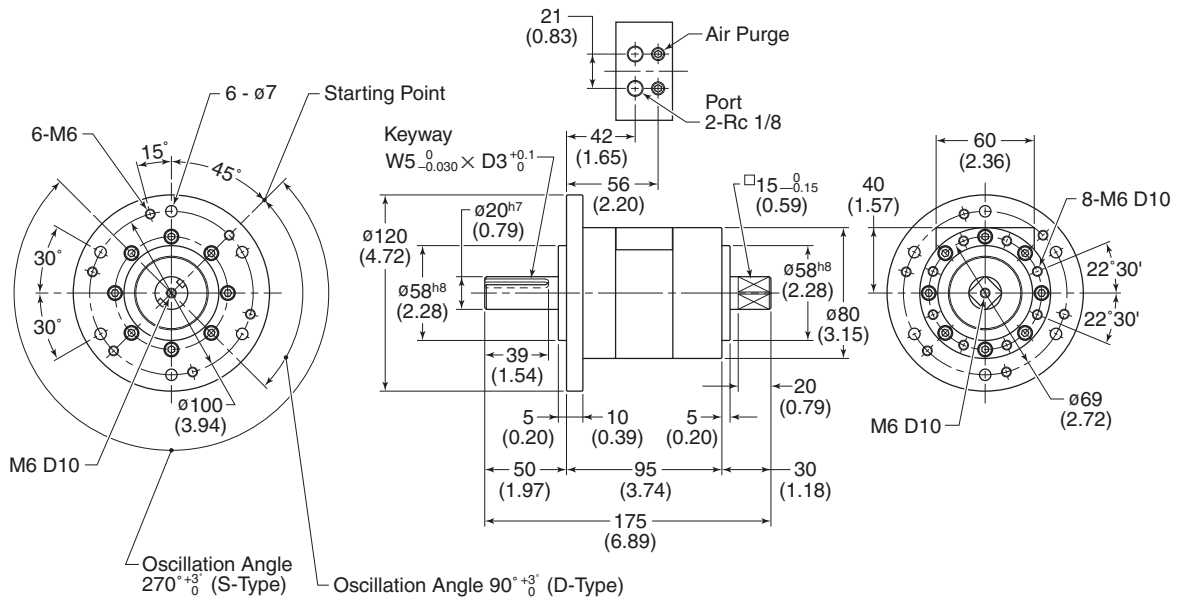

Note: For Double Vane, 2 Keyways are Provided

Dimensions are in mm (Inches)

**HRN100S/D**

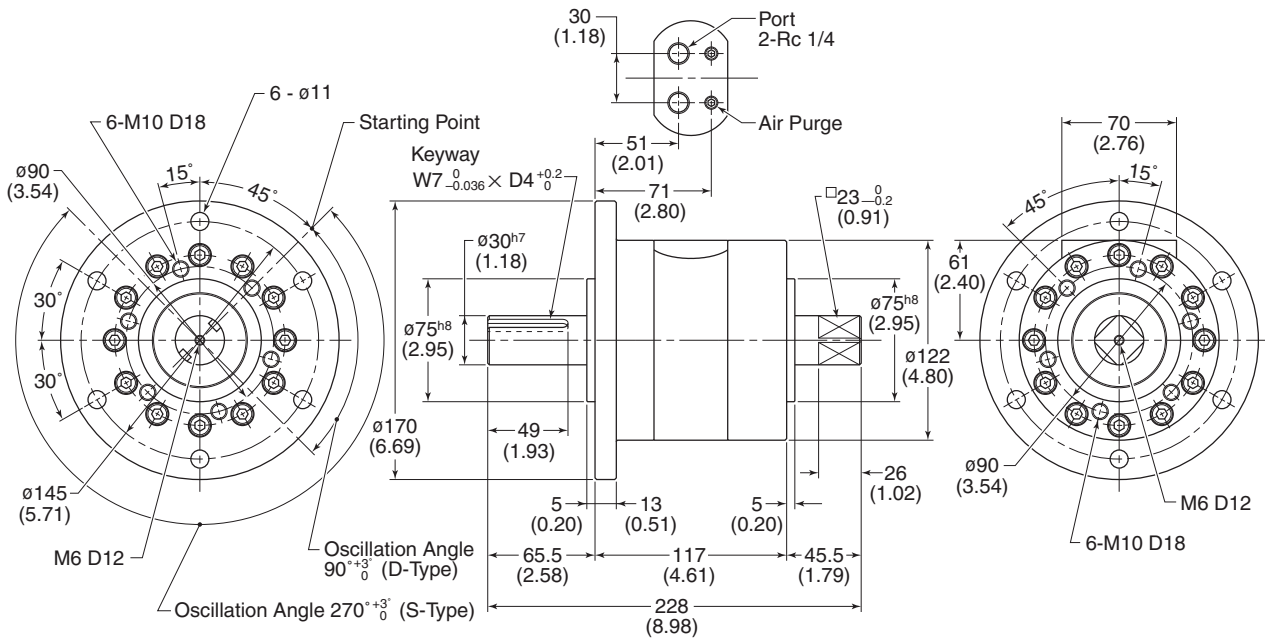

Note: For Double Vane, 2 Keyways are Provided

**HRN200S/D**

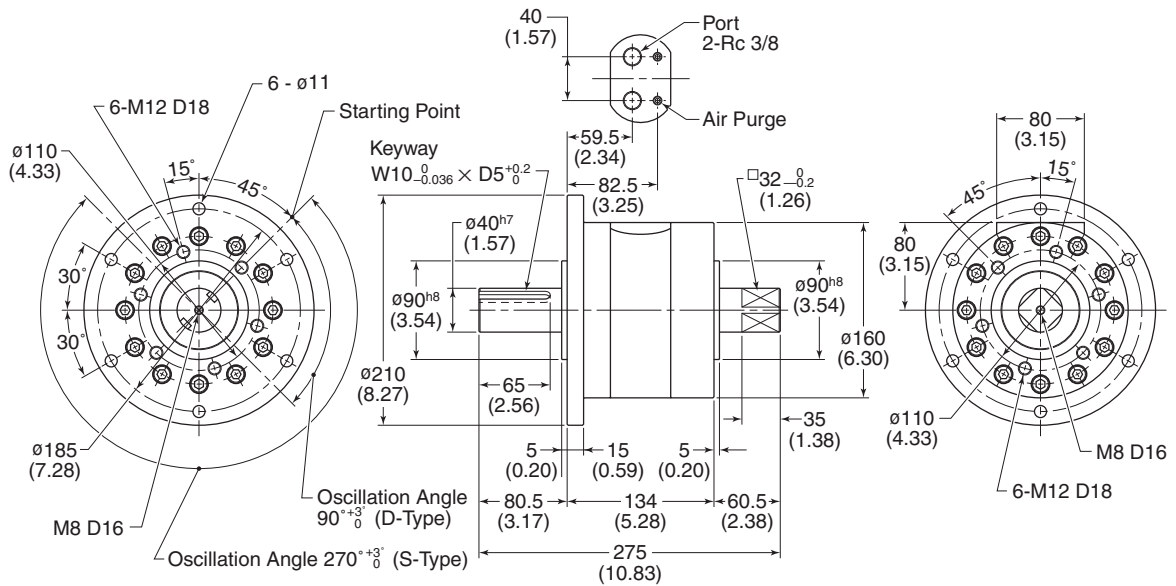

Note: For Double Vane, 2 Keyways are Provided

Dimensions are in mm (Inches)

**HRN400S/D**

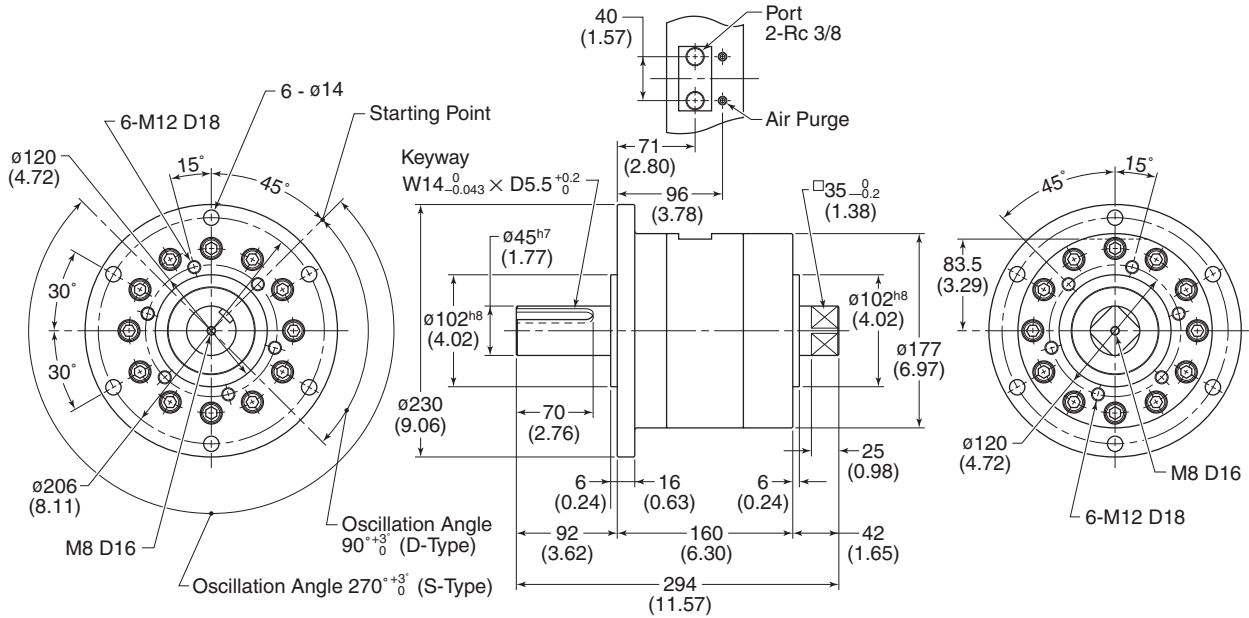

**HRN700S/D**

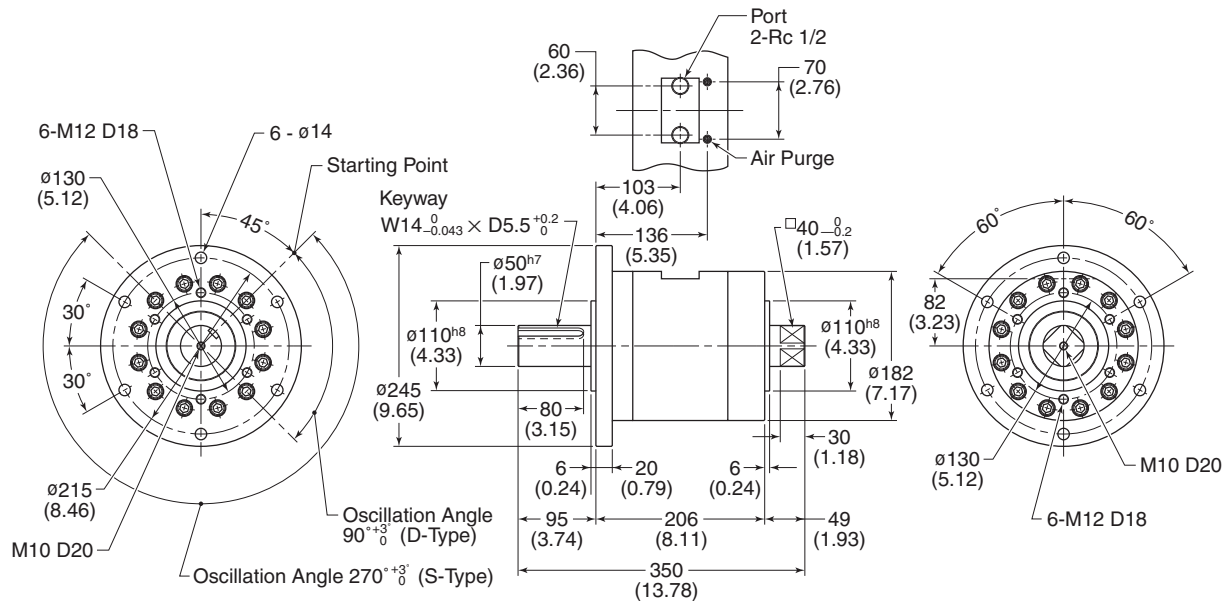

Dimensions are in mm (Inches)

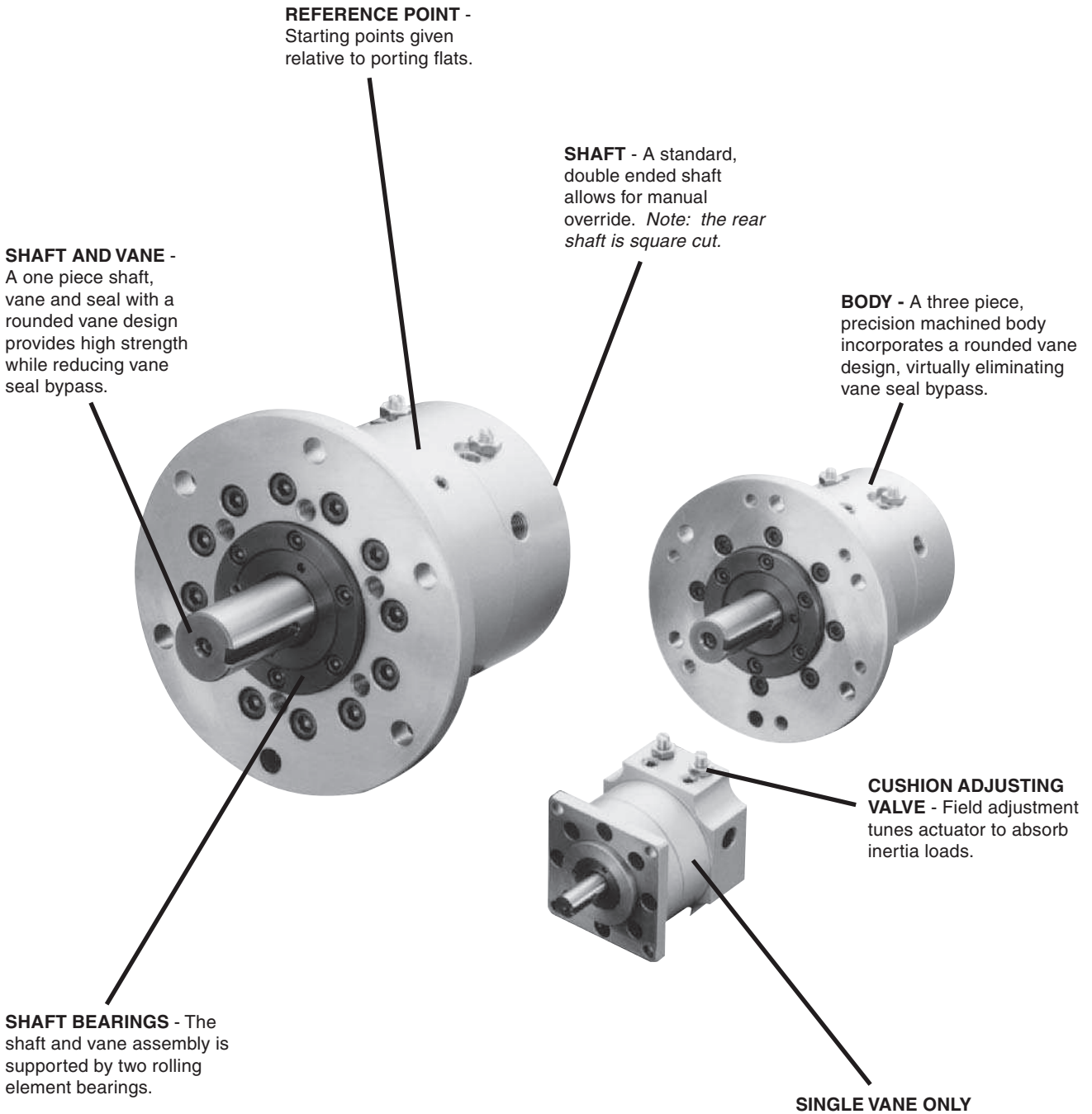

**HRN-C Series**

The HRN-C Series provides an additional range of vane actuator technology. Unique cushion options are available for applications where control of high inertia loads is critical. The actuator incorporates load deceleration cushions which act over the last 20 to 25 degrees of rotation. These are field adjustable and can be selected to meet varying rotational speeds and loading.

The HRN-C Series also incorporates a rounded vane design, which provides lower vane seal bypass. The shaft and vane are machined from high strength alloy steel as one piece. The vane seal is molded in a pre-machined groove in order to provide a one piece shaft, vane, and seal assembly for long life and reliability. The standard rear output shaft provides for an easily accessible manual override in the event that hydraulic pressure is lost.

Available options include rotations of 90 degrees and 180 degrees with the unit configured as a single vane arrangement. Reference points (or keyway timing) are provided relative to the port positioning. Large, convenient, front flange with precision pilot diameter allows for concise mounting and easy integration with the customer's application.

**Specifications**

- Rated Operating Pressure: 7 MPa (1000 psi)
- Minimum Operating Pressure: 1 MPa (145 psi)
- Output Torque @ 7 MPa: 10 to 1960 N•m (89 to 17346 in-lb)
- Standard Rotations: 90° to 270°
- Operating Temperature Range: 0°C to 60°C (32°F to 140°F)
- Filtration Requirement: ISO Class 17/14 Cleanliness Level
- Mounting Orientation: Unrestricted
- Standard Keyway Timing: See Figures for Start Position

**Vane Actuators**  
**HRN-C**  
 Torq-Mor

**Quick Reference Data**

Model Number		Theoretical Output Torque				Maximum Breakaway Pressure	Unit Weight
		1.75 MPa (250 psi)	3.50 MPa (500 psi)	5.00 MPa (750 psi)	7.00 MPa (1000 psi)		
		N•m (in-lb)	N•m (in-lb)	N•m (in-lb)	N•m (in-lb)	MPa (psi)	kg (lb)
Single Vane	HRN10S-C	2 (17.7)	5 (44.3)	7 (62.0)	10 (88.5)	1.00 (145)	1.20 (2.65)
	HRN15S-C	3 (26.6)	8 (70.8)	13 (115.1)	20 (177.0)	1.00 (145)	2.40 (5.29)
	HRN20S-C	8 (70.8)	13 (115.1)	23 (203.6)	29 (256.7)	1.00 (145)	3.30 (7.28)
	HRN30S-C	10 (88.5)	26 (230.1)	38 (336.3)	58 (513.3)	1.00 (145)	4.70 (10.36)
	HRN100S-C	23 (203.6)	56 (495.6)	92 (814.2)	123 (1088.6)	1.00 (145)	13.50 (29.77)
	HRN200S-C	45 (398.3)	124 (1097.4)	212 (1876.2)	314 (2778.9)	1.00 (145)	25.70 (56.67)
	HRN400S-C	170 (1504.5)	250 (2212.5)	398 (3522.3)	539 (4770.2)	1.00 (145)	34.00 (74.97)
	HRN700S-C	201 (1778.9)	410 (3628.5)	579 (5124.2)	1078 (9540.3)	1.00 (145)	44.00 (97.02)

**Model Code and Ordering Information**

Example: HRN100S-C90

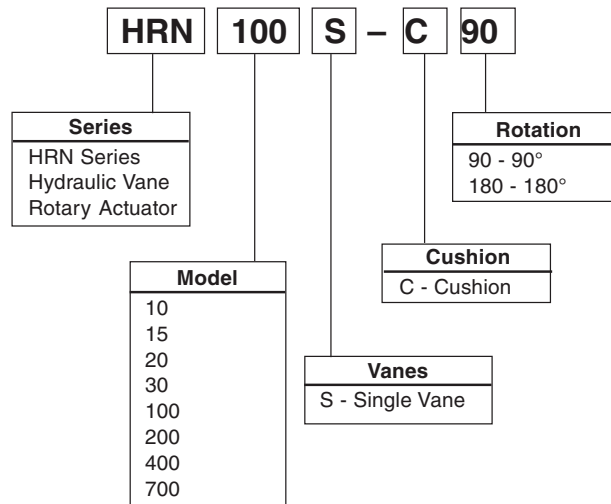

**Oscillation Starting Point**

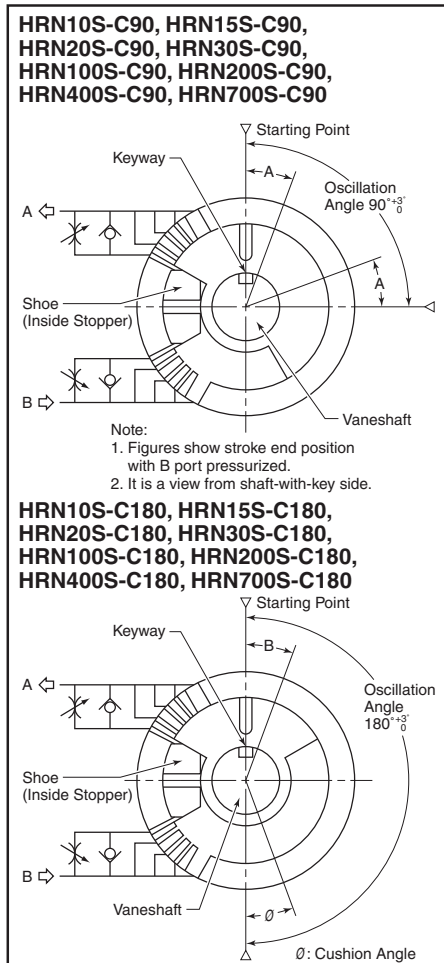

Model No.	Unit Size	HRN10S-C		HRN15S-C		HRN20S-C		HRN30S-C	
Vane		Single Vane							
Rotation	Degree	90	180	90	180	90	180	90	180
Rotational Tolerance	Degree	+3 -0							
Reference Point	Degree	90							
Port Size		Rc 1/8							
Operating Pressure Range	MPa	1.0 to 7.0							
	psi	145.0 to 1015.0							
Temperature Range	°C	0 to 60							
	°F	32 to 140							
Displacement	cm <sup>3</sup>	6.5	3.3	11.0	5.5	16.0	8.0	34.0	17.0
	in <sup>3</sup>	0.40	0.20	0.67	0.30	0.98	0.49	2.07	1.04
Internal Bypass Leakage at 40°C	cm <sup>3</sup> /min	10		15		20		30	
Maximum Moment of Inertia	in-lb	8.5		17.0		25.5		50.9	
Maximum Inrush Angular Velocity	Radian/s	10.4720							
	Degree/s	600							
Cushion Angle	Radian	0.3491			0.4363				
	Degree	20			25				
Oscillating Angle Before Cushioning	Radian	1.2217	2.7925	1.1345	2.7053	1.1345	2.7053	1.1345	2.7053
	Degree	70	160	65	155	65	155	65	155

Model No.	Unit Size	HRN100S-C		HRN200S-C		HRN400S-C		HRN700S-C	
Vane		Single Vane							
Rotation	Degree	90	180	90	180	90	180	90	180
Rotational Tolerance	Degree	+3 -0							
Reference Point	Degree	90							
Port Size		Rc 1/4		Rc 3/8			Rc 1/2		
Operating Pressure Range	MPa	1.0 to 7.0							
	psi	145.0 to 1015.0							
Temperature Range	°C	0 to 60							
	°F	32 to 140							
Displacement	cm <sup>3</sup>	74.0	37.0	147.0	73.5	290.0	145.0	520.0	260.0
	in <sup>3</sup>	4.52	2.26	8.97	4.49	17.70	8.85	31.70	15.90
Internal Bypass Leakage at 40°C	cm <sup>3</sup> /min	50		100		100		100	
Maximum Moment of Inertia	in-lb	127.3		339.5		594.3		1188.0	
Maximum Inrush Angular Velocity	Radian/s	8.7266		6.9813		5.2360		4.3633	
	Degree/s	500		400		300		250	
Cushion Angle	Radian	0.4363							
	Degree	25							
Oscillating Angle Before Cushioning	Radian	1.1345	2.7053	1.1345	2.7053	1.1345	2.7053	1.1345	2.7053
	Degree	65	155	65	155	65	155	65	155

**Kinetic Energy Ratings and Bearing Load Capacities**

Model Number	Bearing Load Capacities				Maximum Inertia Energy Rating	
	Thrust Load		Radial Load		J	in-lb
	N	lb	N	lb		
HRN10S-C	4.9	1.1	9.8	2.0	0.013	0.12
HRN15S-C	9.8	2.2	19.6	4.0	0.025	0.22
HRN20S-C	24.5	5.5	49.0	11.0	0.046	0.41
HRN30S-C	39.2	8.8	78.4	18.0	0.088	0.78
HRN100S-C	68.6	15.4	147.0	33.0	0.260	2.26
HRN200S-C	137.2	30.8	294.0	66.0	0.510	4.51
HRN400S-C	166.6	37.5	343.0	77.0	0.760	6.68
HRN700S-C	166.6	37.5	343.0	77.0	0.910	8.06

Note: The allowable inertia energy is applicable when the load is installed on the keyed input shaft.

**Maximum Absorbed Energy**

Model Number	Maximum Absorbed Energy J (in-lb)					
	Operating Pressure MPa (psi)					
	1.96 (284)	2.94 (426)	3.92 (569)	4.90 (710)	5.88 (853)	6.86 (995)
HRN10S-C	2.06 (18.23)	1.76 (15.58)	1.47 (13.01)	1.18 (10.44)	0.88 (7.79)	0.59 (5.22)
HRN15S-C	4.80 (42.48)	4.12 (36.46)	3.43 (30.36)	2.74 (24.25)	2.06 (18.23)	1.37 (12.12)
HRN20S-C	7.55 (66.82)	6.47 (57.26)	5.39 (47.70)	4.31 (38.14)	3.23 (28.59)	2.16 (19.12)
HRN30S-C	15.09 (133.55)	12.94 (114.52)	10.78 (95.40)	8.62 (76.29)	6.47 (57.26)	4.31 (38.14)
HRN100S-C	30.87 (273.20)	26.46 (234.17)	22.05 (195.14)	17.64 (156.11)	13.23 (117.09)	8.62 (76.29)
HRN200S-C	78.89 (698.18)	67.62 (598.44)	56.35 (498.70)	45.08 (398.96)	33.81 (299.22)	22.54 (199.48)
HRN400S-C	137.20 (1214.22)	117.60 (1040.76)	98.00 (867.30)	78.40 (693.84)	58.80 (520.38)	39.20 (346.92)
HRN700S-C	250.39 (2215.95)	214.62 (1899.39)	178.85 (1582.82)	143.08 (1266.26)	107.31 (949.69)	71.54 (633.13)

1800\_HRN.pmd, M&A



**Vane Actuators**  
**HRN-C**  
 Torq-Mor

**HRN10S-C**

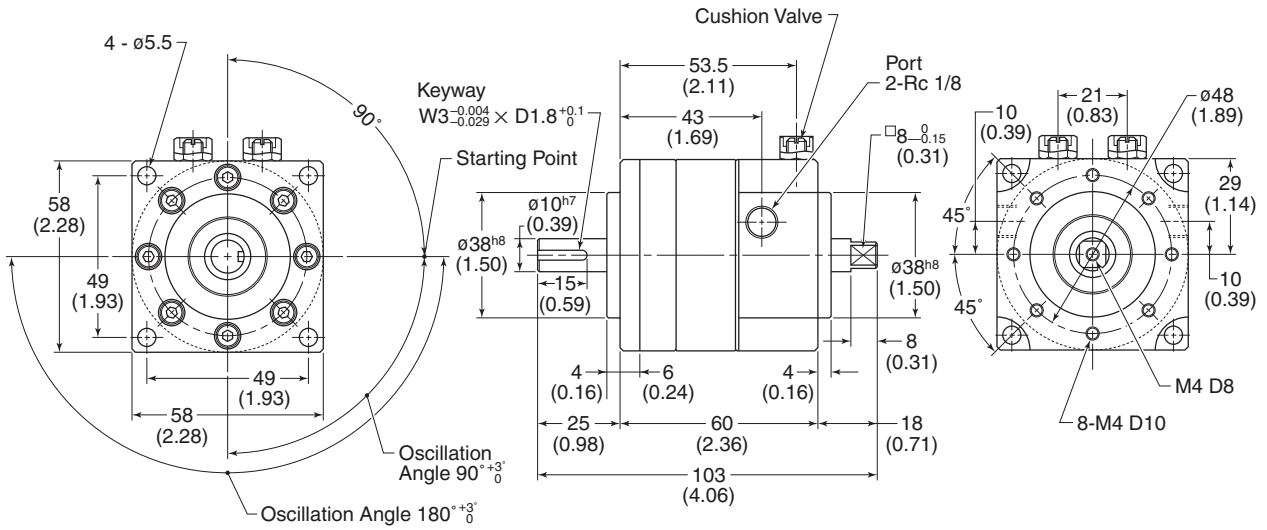

**HRN15S-C**

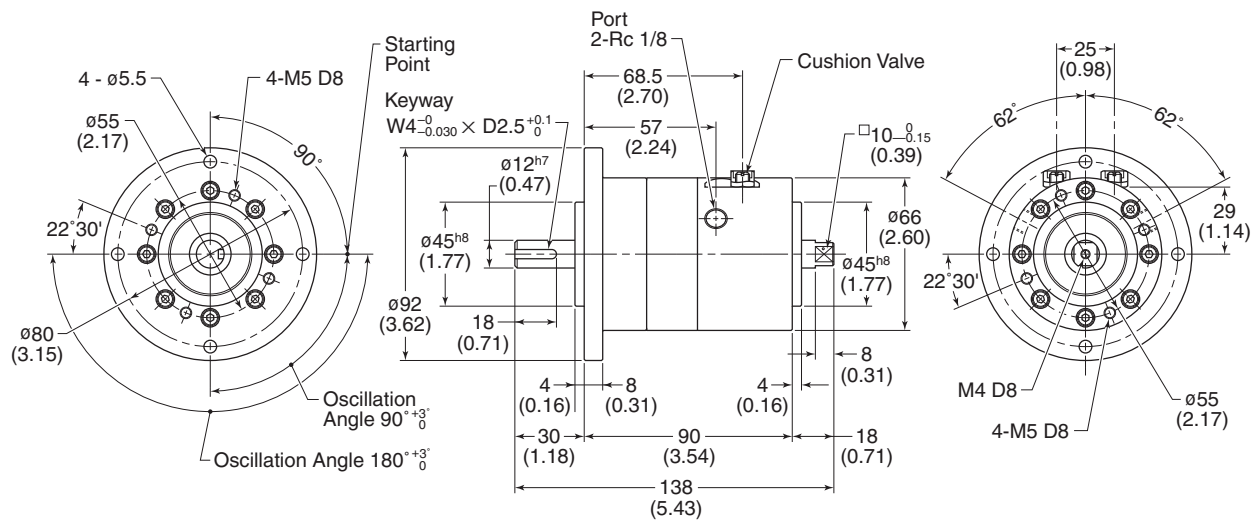

Dimensions are in mm (Inches)



**HRN20S-C**

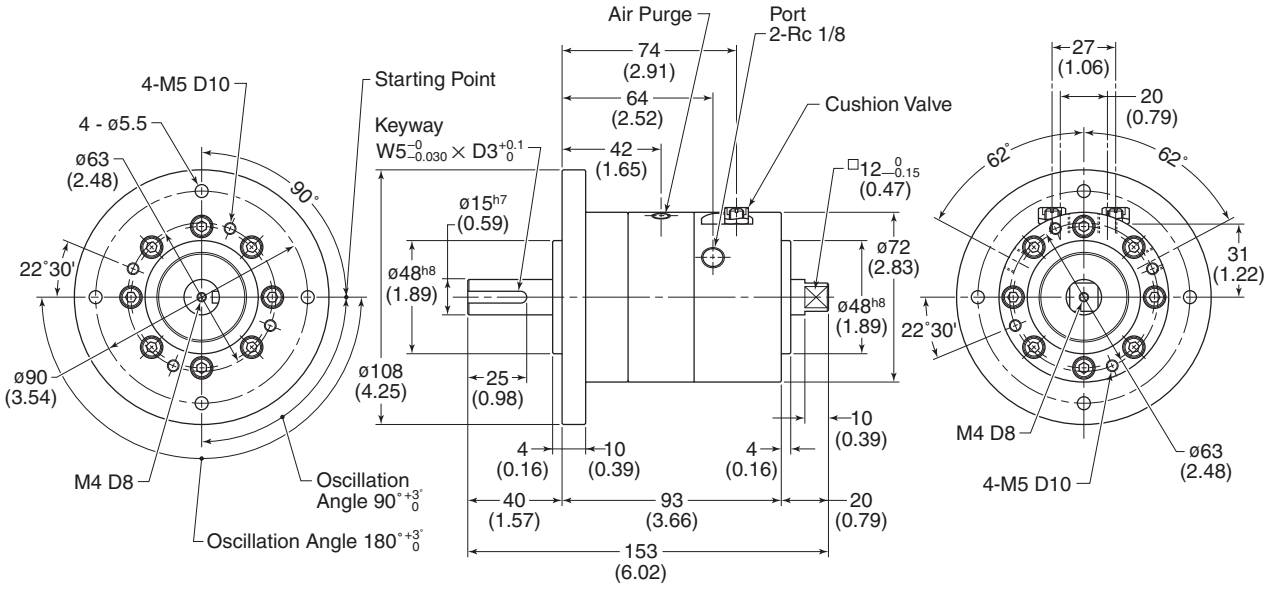

**HRN30S-C**

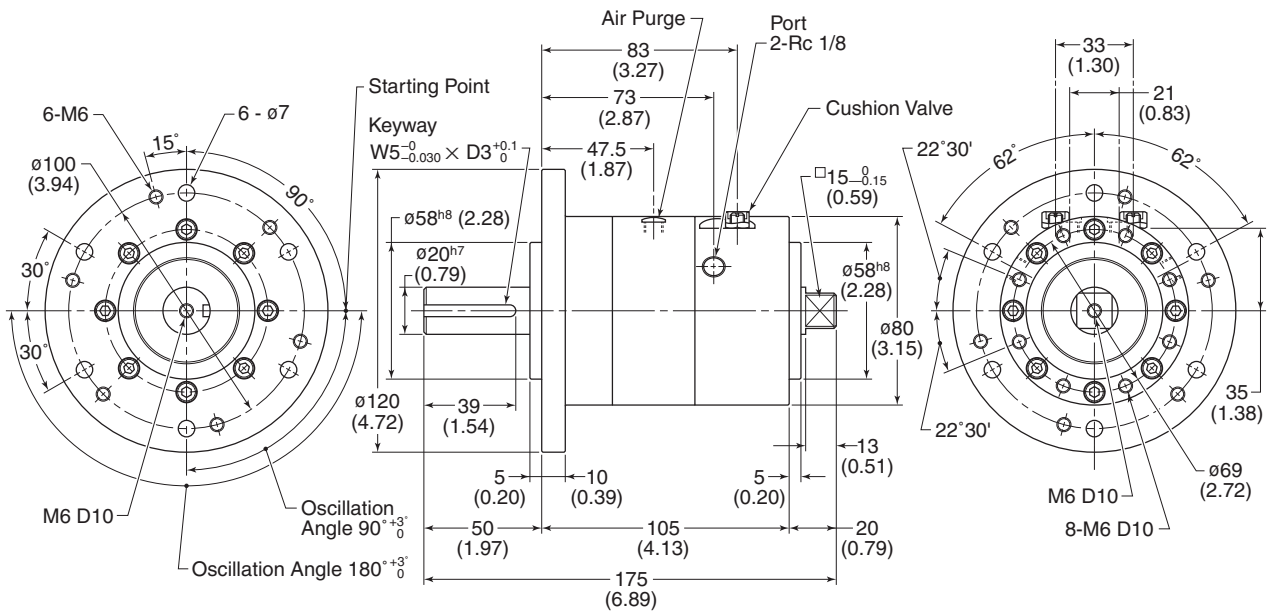

Dimensions are in mm (Inches)

**HRN100S-C**

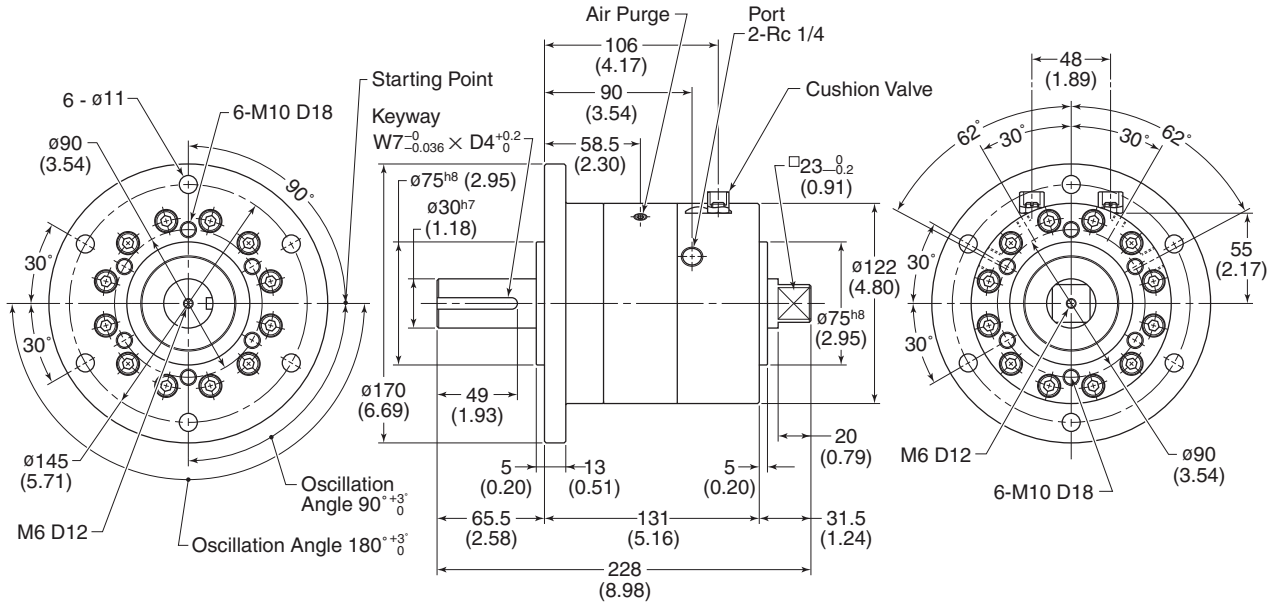

**HRN200S-C**

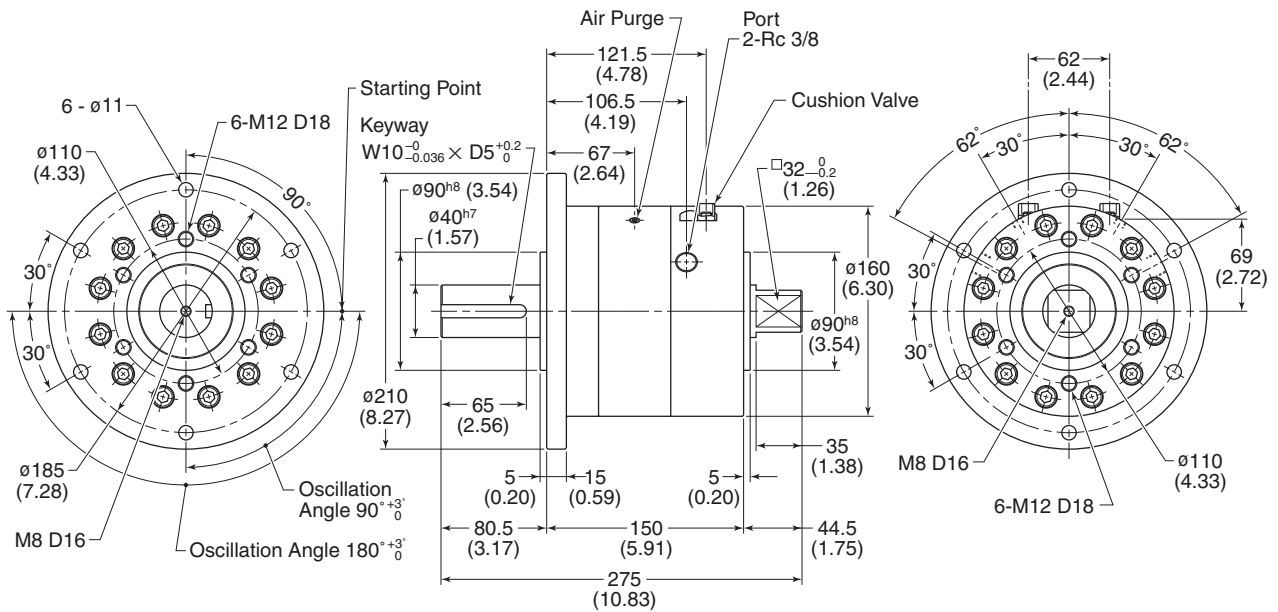

Dimensions are in mm (Inches)

**HRN400S-C**

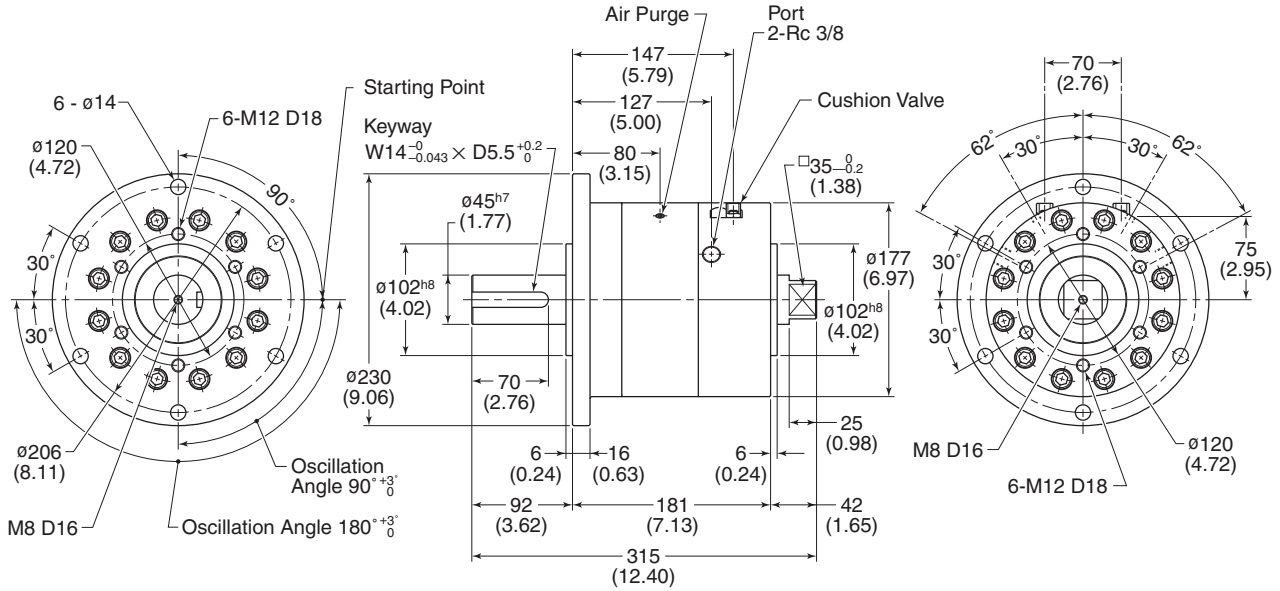

**HRN700S-C**

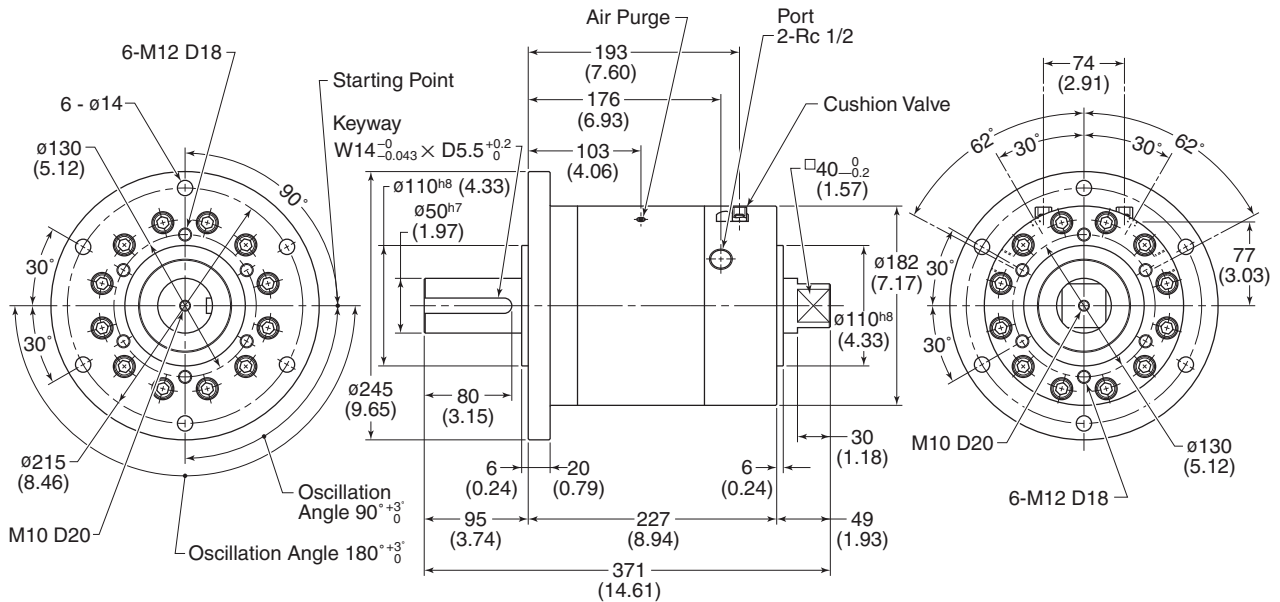

Dimensions are in mm (Inches)

**Dimensions**

**Keys for HRN Series Actuators**

HRN Series Actuators with keyways are accompanied by the following keys, respectively.

Model No.	Key Size	Quantity	
		Standard	With Cushion
HRN10	3 x 3 x 15	1	1
HRN15	4 x 4 x 18	1	1
HRN20	5 x 5 x 25	1	1
HRN30	5 x 5 x 39	Single Bane: 1 Double Bane: 2	1
HRN100	7 x 7 x 49	Single Bane: 1 Double Bane: 2	1
HRN200	10 x 8 x 65	Single Bane: 1 Double Bane: 2	1
HRN400	14 x 9 x 70	1	1
HRN700	14 x 9 x 80	1	1

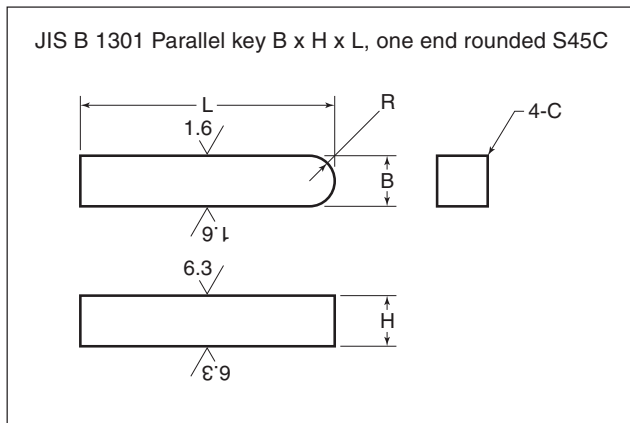

Dimensions are in mm

Key Size	B	H	L	C	R
3 x 3 x 15	3 <sup>0</sup> <sub>-0.05</sub>	3 <sup>0</sup> <sub>-0.25</sub>	15 <sup>0</sup> <sub>-0.18</sub>	0.16 – 0.25	1.5
4 x 4 x 18	4 <sup>0</sup> <sub>-0.03</sub>	4 <sup>0</sup> <sub>-0.03</sub>	18 <sup>0</sup> <sub>-0.18</sub>	0.16 – 0.25	2
5 x 5 x 25	5 <sup>0</sup> <sub>-0.03</sub>	5 <sup>0</sup> <sub>-0.03</sub>	25 <sup>0</sup> <sub>-0.21</sub>	0.25 – 0.40	2.5
5 x 5 x 39	5 <sup>0</sup> <sub>-0.03</sub>	5 <sup>0</sup> <sub>-0.03</sub>	39 <sup>0</sup> <sub>-0.25</sub>	0.25 – 0.40	2.5
7 x 7 x 49	7 <sup>0</sup> <sub>-0.036</sub>	7 <sup>0</sup> <sub>-0.036</sub>	49 <sup>0</sup> <sub>-0.025</sub>	0.25 – 0.40	3.5
10 x 8 x 65	10 <sup>0</sup> <sub>-0.036</sub>	8 <sup>0</sup> <sub>-0.09</sub>	65 <sup>0</sup> <sub>-0.3</sub>	0.4 – 0.6	5
14 x 9 x 70	14 <sup>0</sup> <sub>-0.043</sub>	9 <sup>0</sup> <sub>-0.09</sub>	70 <sup>0</sup> <sub>-0.3</sub>	0.4 – 0.6	7
14 x 9 x 80	14 <sup>0</sup> <sub>-0.043</sub>	9 <sup>0</sup> <sub>-0.09</sub>	80 <sup>0</sup> <sub>-0.3</sub>	0.4 – 0.6	7



# Tork-Mor Series

Vane Style Hydraulic  
Rotary Actuators

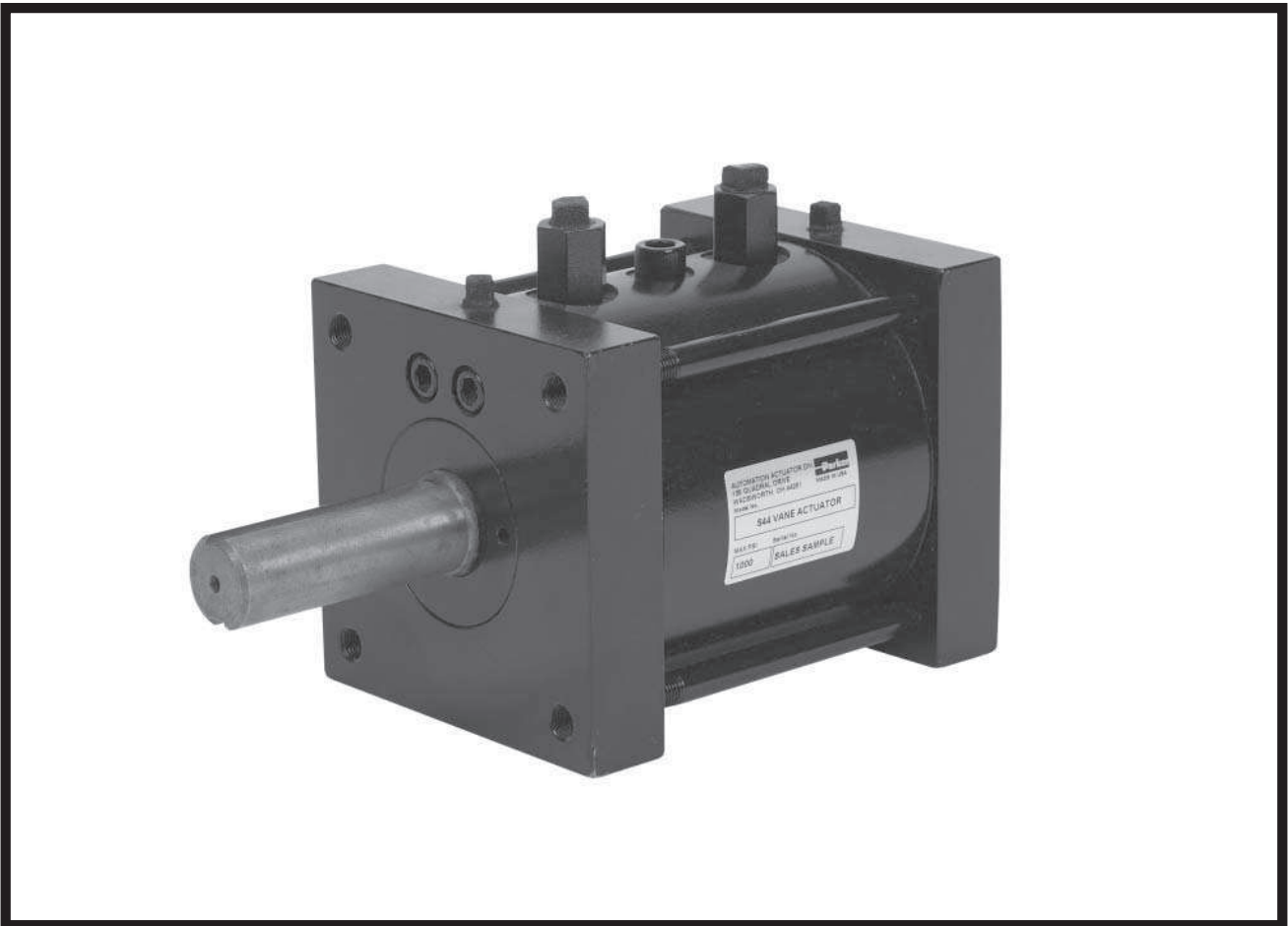

Vane Actuators

HRN

Tork-Mor

## Contents

Features .....	2
Ordering Information .....	3
Specifications .....	4
Dimensional Data .....	5
Options	
Mounting Options .....	6-7
Shaft Options .....	7
Limit Switch Actuator .....	7
Taper Lock Stop .....	8
Thrust Bearings .....	8



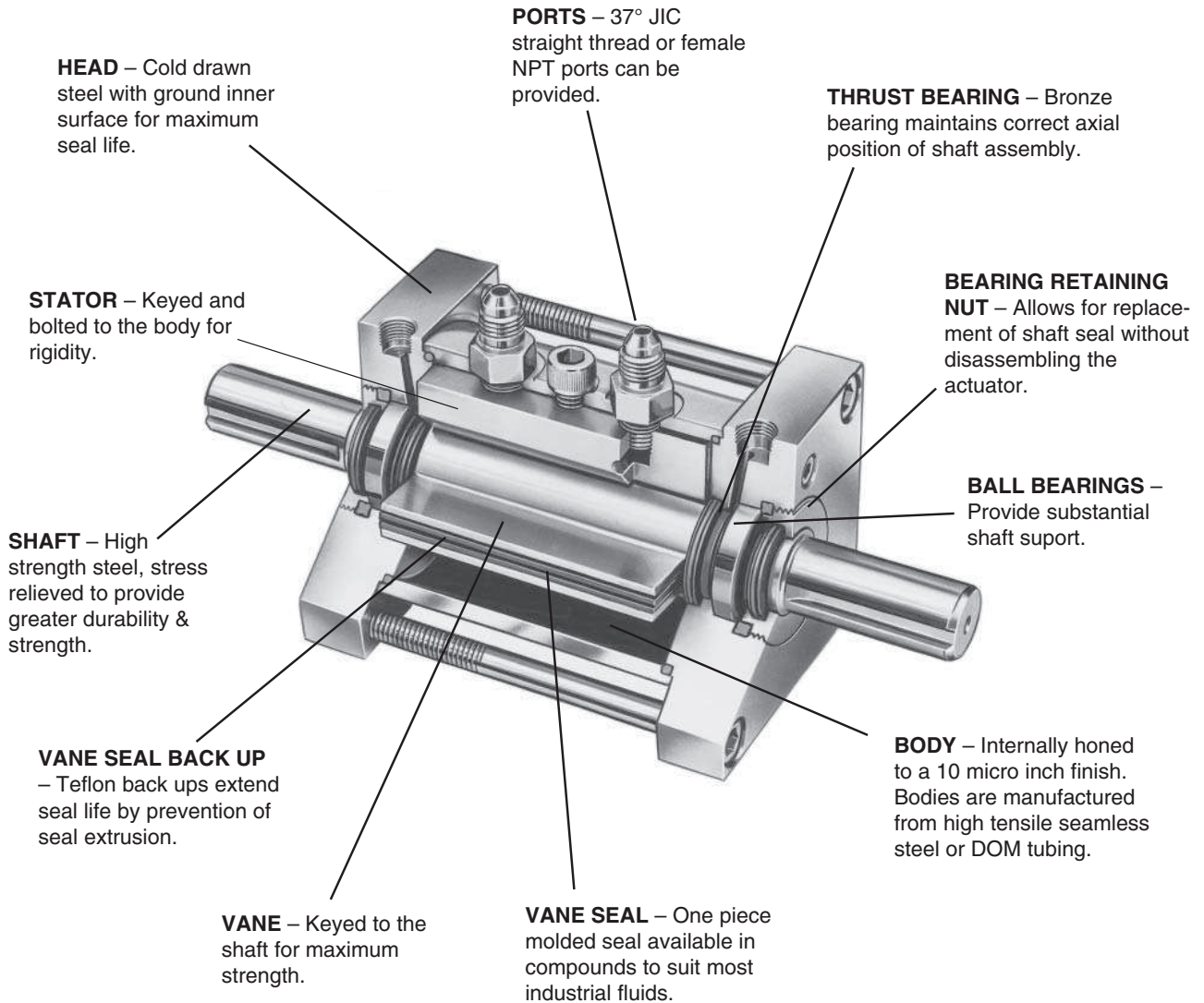

**Model Code and Ordering Information**

Example: S42-BB5

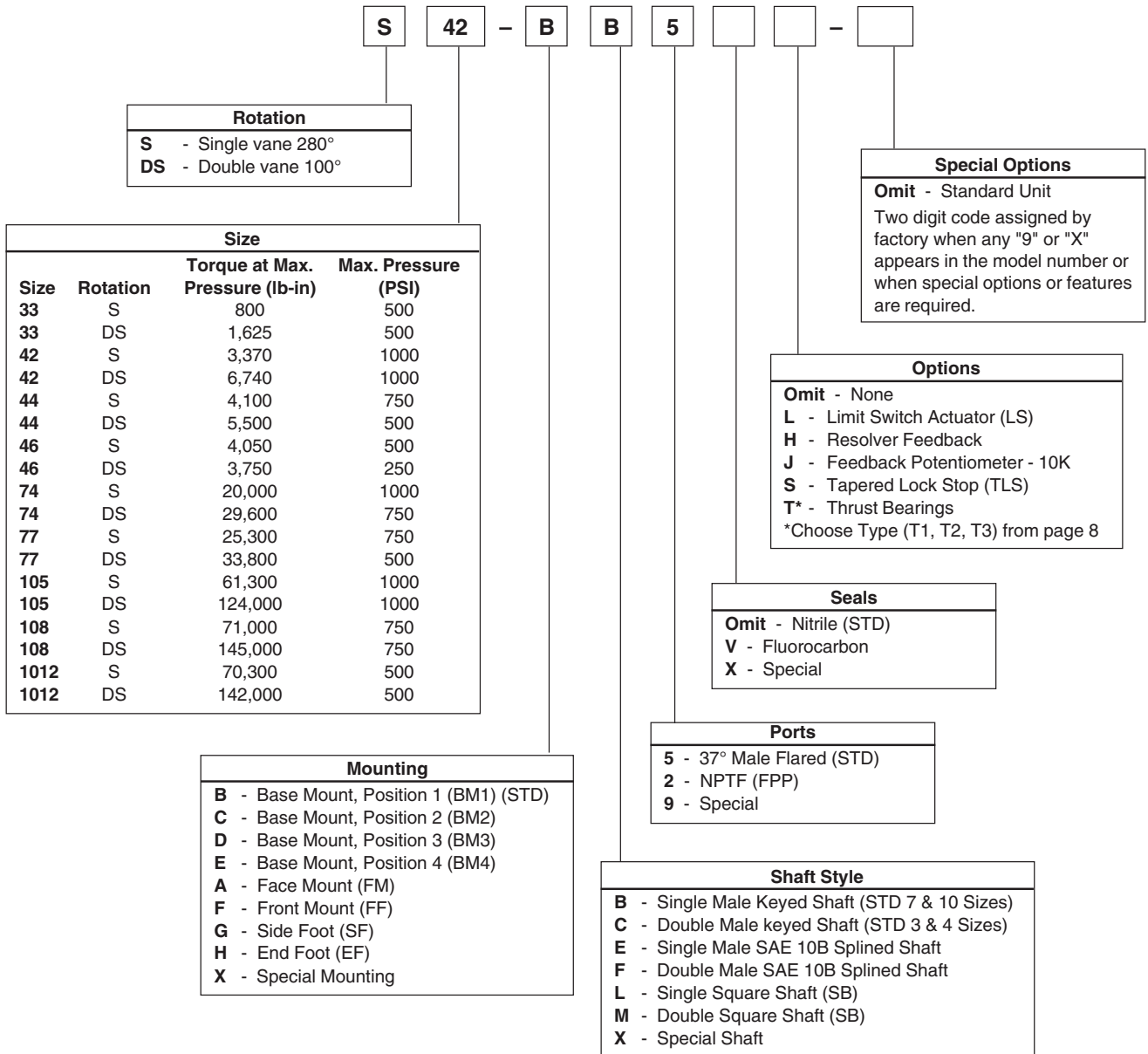

Vane Actuators  
 HRN  
 Tork-Mor

**Tork-Mor Series**

Tork-Mor Series actuators are produced in eighteen sizes generating up to 145,000 lb-in of torque at rated pressure. Capable of providing full torque instantly in either direction, they are available with 100° or 280° rotation at pressures up to 1000 psi. The Tork-Mor Series can be mounted in any axis using a wide variety of standard or optional mountings.

Proven reliable through many years of field service, the Tork-Mor Series incorporates many quality features including precision ball bearings to provide shaft support, externally removable gland for ease of seal replacement and cylinders honed to a 10 micro inch finish to ensure long seal life.

**Specifications**

- **Rated Operating Pressure:**  
 Pneumatic – 250 psi  
 Hydraulic – See table below
- **Rotations:** S Models – 280° ± 1°; DS Models – 100° ± 1°
- **Max. Allowable Drainline Pressure :** Hydraulic – 50 PSI;  
 Pneumatic – Drain lines are not necessary; plug drain ports
- **External Shaft Load Capacities:**  
 Thrust Loads: Units have no thrust load capacity. See page 8 for optional thrust load bearings and their capacities.  
 Radial Loads: External radial loads are not recommended and can reduce the life of the unit. Consult factory before applying.
- **Installation and Operating:** Read instructions in Maintenance & Installation Section of this catalog before applying Tork-Mor Series actuators.

**Model Quick Reference**

Model		Rated Pressure (psi)		Output Torque						Capacity (cu. in.)	Max. Bypass Leakage		Max. Breakaway Pressure (psi)	Unit Weights (lbs)
280° Rotation	100° Rotation	Normal Operating	Non-Shock	50 psi	100 psi	250 psi	500 psi	750 psi	1000 psi		100 psi Air (cfm)	500 psi Oil* (cu.in./min)		
S33	—	350	500	38	115	360	800	—	—	8.7	.20	2.5	25	8
—	DS33	350	500	77	235	728	1,625	—	—	6.2	.25	3.0	25	8.5
S42	—	750	1000	85	240	750	1,640	2,350	3,370	17.9	.25	3.0	25	16
—	DS42	750	1000	170	480	1,500	3,280	4,700	6,740	12.8	.30	3.5	25	19
S44	—	500	750	160	415	1,280	2,700	4,100	—	31.8	.25	3.0	25	22
—	DS44	350	500	325	840	2,570	5,500	—	—	22.6	.30	3.5	25	23
S46	—	350	500	240	600	1,850	4,050	—	—	47.7	.25	3.0	25	25
—	DS46	150	250	490	1,220	3,750	—	—	—	34.1	.30	3.5	25	27
S74	—	750	1,000	540	1,390	4,230	9,500	14,500	20,000	106	.30	3.5	25	92
—	DS74	500	750	1,080	2,800	8,560	19,300	29,600	—	75.7	.35	4.0	25	118
S77	—	500	750	950	2,430	7,400	16,700	25,300	—	186	.30	3.5	25	105
—	DS77	350	500	1,900	4,900	15,000	33,800	—	—	133	.35	4.0	25	120
S105	—	750	1,000	1,660	4,260	13,000	29,300	44,500	61,300	326	.30	5.0	25	290
—	DS105	750	1,000	3,330	8,650	26,300	59,300	90,900	124,000	233	.35	5.5	25	345
S108	—	500	750	2,660	6,820	20,800	46,900	71,000	—	521	.30	5.0	25	340
—	DS108	500	750	5,330	13,900	42,100	94,800	145,000	—	372	.35	5.5	25	362
S1012	—	350	500	3,990	10,200	31,200	70,300	—	—	781	.30	5.0	25	365
—	DS1012	350	500	7,990	20,800	63,100	142,000	—	—	558	.35	5.5	25	400





**Series 3 & 4 with Std. Base Mount (B) and Double Male Keyed Shaft (C)**

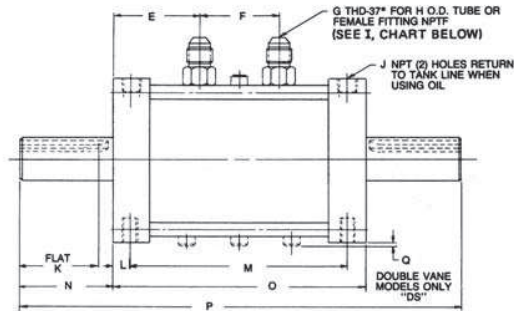
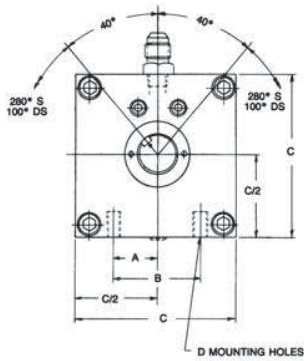

Model	A	B	C	D	E	F	G	H	I	J	K	L	M	N	O	P	Q
S & DS33	0.813	1.625	3.00	5/16-18 NC x .47 DP	1 1/8	1 1/2	7/16 - 20	1/4	1/8	1/8-27	1.50	.38	4	1.75	4 3/4	8 1/4	1/4
S & DS42	1.188	2.375	4.50	3/8-16 NC x .56 DP	1 1/8	1	9/16-18	3/8	1/4	1/8-27	2.50	.50	3 1/4	3.00	4 1/4	10 1/4	9/32
S & DS44	1.188	2.375	4.50	3/8-16 NC x .56 DP	1 3/4	2 1/2	9/16-18	3/8	1/4	1/8-27	2.50	.50	5	3.00	6	12	9/32
S & DS46	1.188	2.375	4.50	3/8-16 NC x .56 DP	2 3/4	2 1/2	9/16-18	3/8	1/4	1/8-27	2.50	.50	7	3.00	8	14	9/32

**Shaft Details for Standard Male Keyed Shafts (B & C)**

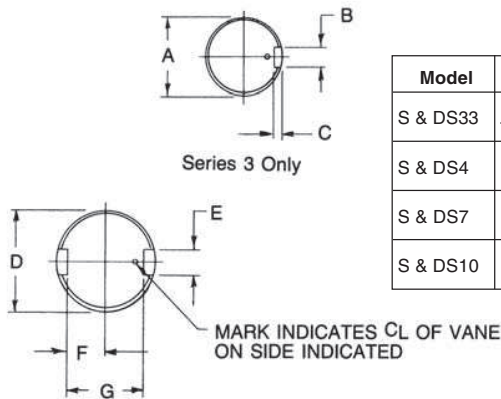

Model	A	B	C	D	E	F	G
S & DS33	.749 +.000 -.001	.188 +.001 -.000	.093 +.000 -.003	N/A	N/A	N/A	N/A
S & DS4	N/A	N/A	N/A	.999 +.000 -.001	.250 +.000 -.001	.390 +.000 -.001	.780 +.000 -.002
S & DS7	N/A	N/A	N/A	1.749 +.000 -.001	.375 +.002 -.000	.730 +.00 -.002	1.460 +.000 -.010
S & DS10	N/A	N/A	N/A	2.999 +.000 -.001	.750 +.002 -.000	1.200 +.000 -.003	2.400 +.000 -.010

**Series 7 & 10 with Std. Base Mount (B) and Single Male Keyed Shaft (B)**

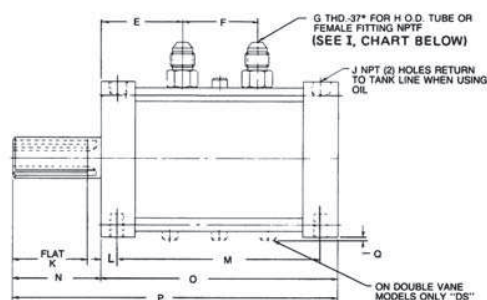
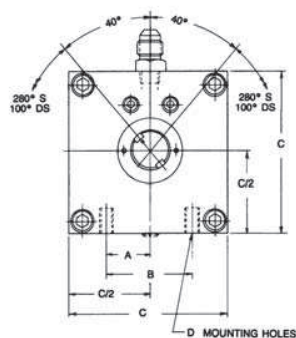

Model	A	B	C	D	E	F	G	H	I	J	K	L	M	N	O	P	Q
S & DS74	1.875	3.750	8.00	3/4-10 NC x 1.13 DP	2 11/16	1 5/8	1 1/16 - 12	3/4	3/4	1/8-27	5.00	.69	5 5/8	5.50	7	12.50	5/8
S & DS77	1.875	3.750	8.00	3/4-10 NC x 1.13 DP	3 3/8	3 1/4	1 1/16 - 12	3/4	3/4	1/8-27	5.00	.69	8 5/8	5.50	10	15.50	5/8
S & DS105	3.000	6.000	12.25	1-14 NC x 1.50 DP	3 3/4	2 1/2	1 5/16 - 12	1	1	1/4-18	8.00	1.25	7 1/2	9.00	10	19.00	5/8
S & DS108	3.000	6.000	12.25	1-14 NC x 1.50 DP	4 1/4	4 1/2	1 5/16 - 12	1	1	1/4-18	8.00	1.25	10 1/2	9.00	13	22.00	5/8
S & DS1012	3.000	6.000	12.25	1-14 NC x 1.50 DP	6 1/4	4 1/2	1 5/16 - 12	1	1	1/4-18	8.00	1.25	14 1/2	9.00	17	26.00	5/8

1800\_Tork-Mor.pmd, M&A



**Face Mount (A)  
Base Mount (B, C, D, E)**

In addition to the standard base mounting holes in position 1, similar holes can be provided at position 2, 3 or 4. Alternate mounting holes can also be provided for face mounting as shown.

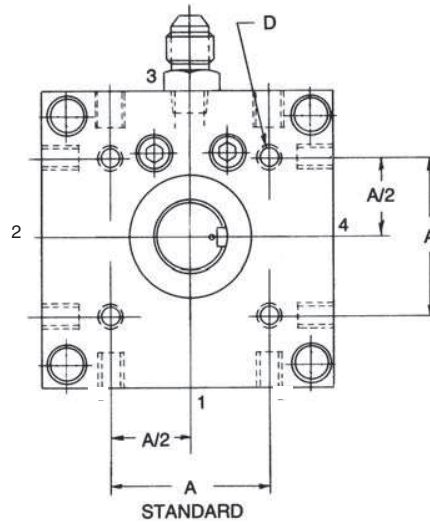

Model	A	D
S & DS33	1 <sup>5</sup> / <sub>8</sub>	<sup>5</sup> / <sub>16</sub> -18 x .47 DP
S & DS4	2 <sup>3</sup> / <sub>8</sub>	<sup>3</sup> / <sub>8</sub> -16 x .56 DP
S & DS7	3 <sup>3</sup> / <sub>4</sub>	<sup>3</sup> / <sub>4</sub> -10 x 1.13 DP
S & DS10	6	1-14 x 1.50 DP

**Front Flange Mount (F)**

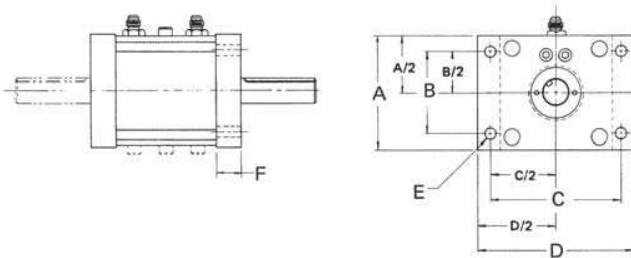

Model	A	B	C	D	E	F
S33	3.00	2.000	3.750	4.625	0.344	0.75
S4	4.50	3.250	5.250	6.25	0.406	1.00
S7	8.00	6.000	9.500	11.00	0.781	1.50
S10	12.25	10.000	14.500	16.50	1.031	2.50

**Side Foot Mount (G)**

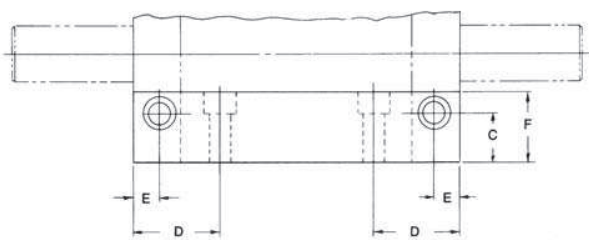

G = BOLT SIZE

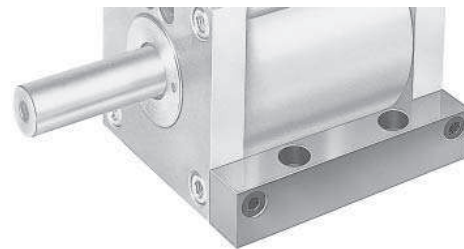

Model	A	B	C	D	E	F	G
SF-3	<sup>3</sup> / <sub>4</sub>	<sup>3</sup> / <sub>8</sub>	<sup>11</sup> / <sub>16</sub>	1 <sup>1</sup> / <sub>4</sub>	<sup>3</sup> / <sub>8</sub>	1	<sup>5</sup> / <sub>16</sub>
SF-4	1	<sup>1</sup> / <sub>2</sub>	1	1 <sup>1</sup> / <sub>4</sub>	<sup>1</sup> / <sub>2</sub>	<sup>1</sup> / <sub>2</sub>	<sup>3</sup> / <sub>8</sub>
SF-7	1 <sup>1</sup> / <sub>2</sub>	<sup>3</sup> / <sub>4</sub>	2	2	<sup>11</sup> / <sub>16</sub>	3	<sup>3</sup> / <sub>4</sub>
SF-10	2	1	3	3 <sup>1</sup> / <sub>4</sub>	1 <sup>1</sup> / <sub>4</sub>	4	1

End Foot Mount (H)

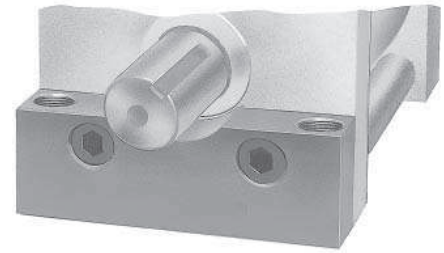
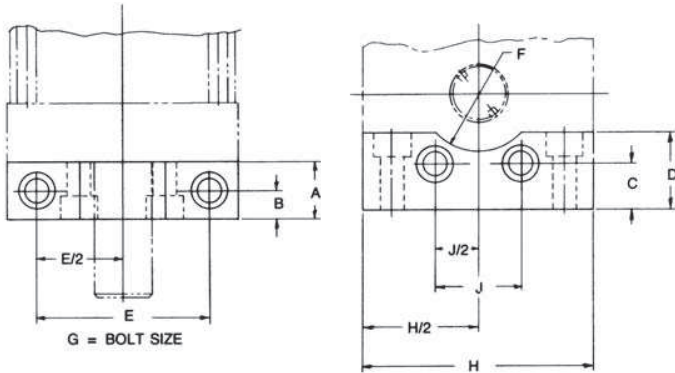

Model	A	B	C	D	E	F	G	H	J
EF-3	3/4	3/8	11/16	1	2 3/4	3/4	5/16	3 1/2	1 5/8
EF-4	1	1/2	1 1/16	1 1/2	3 3/4	1	3/8	4 1/2	2 3/8
EF-7	1 1/2	3/4	2 1/8	3	6 3/8	1 1/2	3/4	8	3 3/4
EF-10	2	1	3 1/8	4 1/2	10	1 3/4	1	12 1/4	6

Shaft Options

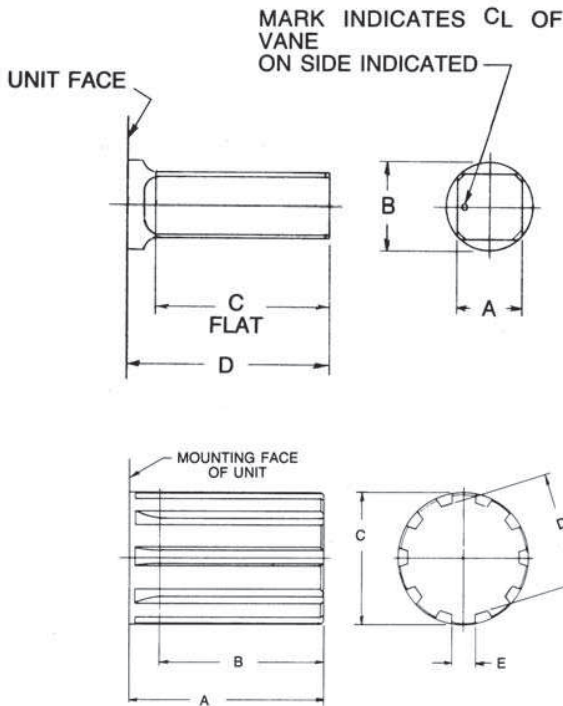

Optional shafts are available as shown. Output shafts can also be provided to your special requirements.

Square Shafts (L, M)

Model	A	B	C	D
S33	.564 <sup>+0.000</sup> / <sub>-.001</sub>	.749 <sup>+0.000</sup> / <sub>-.001</sub>	1 1/2	1 3/4
S4	.815 <sup>+0.000</sup> / <sub>-.001</sub>	.999 <sup>+0.000</sup> / <sub>-.001</sub>	2 1/2	3
S7	1.378 <sup>+0.000</sup> / <sub>-.001</sub>	1.749 <sup>+0.000</sup> / <sub>-.001</sub>	5	5 1/2
S10	2.504 <sup>+0.000</sup> / <sub>-.001</sub>	2.999 <sup>+0.000</sup> / <sub>-.001</sub>	8	9

Splined Shafts (E, F)

Model	A	B	C	D	E
S33	1.75	1.00	.748 .747	.639 .634	.114 .113
S4	2.38	1.50	.998 .997	.854 .849	.153 .152
S7	3.63	2.63	1.748 1.746	1.499 1.494	.270 .269
S10	5.75	4.50	2.997 2.995	2.573 2.568	.464 .463

Limit Switch Actuator (L)

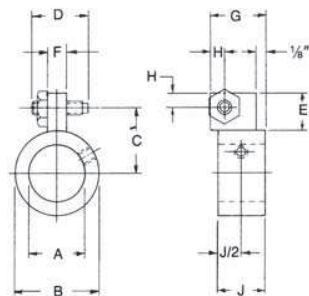

Model	A	B	C	D	E	F	G	H	J
LS-3	3/4	1	7/8	3/4	1/2	1/4	5/8	3/16	5/8
LS-4	1	1 1/2	1 3/8	1	7/8	3/8	1 1/8	1/4	1
LS-7	1 3/4	2 1/4	1 3/4	1	7/8	3/8	1 1/8	1/4	1
LS-10	3	3 3/4	2 5/8	1	1	1/2	1 1/4	1/4	1

**Taper Lock Stop (S)**

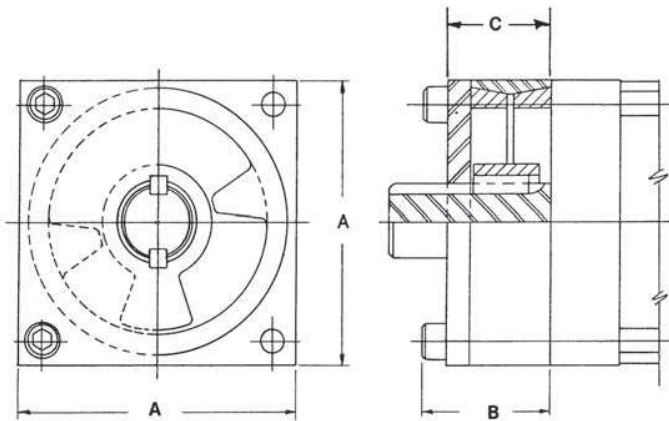

This option provides easy adjustment of rotation for light to medium duty applications.

Model	A	B	C
TLS-3	3	1 <sup>3</sup> / <sub>8</sub>	1 <sup>1</sup> / <sub>8</sub>
TLS-4	4 <sup>1</sup> / <sub>2</sub>	1 <sup>5</sup> / <sub>8</sub>	1 <sup>5</sup> / <sub>16</sub>
TLS-7	8	2 <sup>1</sup> / <sub>2</sub>	2 <sup>1</sup> / <sub>8</sub>

**Thrust Bearings (T1, T2, T3)**

External thrust bearings are advised for axially loaded applications. This includes applications where actuators are mounted in a vertical position causing the weight of the shaft assembly to exert axial thrust.

Model	Thrust Capacity (lbs)	A	B	C	D	E	F	G	H	J	K	L
S3	1600	1 <sup>1</sup> / <sub>32</sub>	3 <sup>3</sup> / <sub>4</sub>	1 <sup>5</sup> / <sub>8</sub>	4 <sup>5</sup> / <sub>8</sub>	3 <sup>3</sup> / <sub>8</sub>	2 <sup>1</sup> / <sub>8</sub>	3 <sup>1</sup> / <sub>16</sub>	1 <sup>9</sup> / <sub>16</sub>	2	1 <sup>3</sup> / <sub>8</sub>	1 <sup>1</sup> / <sub>2</sub>
S4	2500	1 <sup>3</sup> / <sub>32</sub>	5 <sup>1</sup> / <sub>4</sub>	2 <sup>3</sup> / <sub>8</sub>	6	1 <sup>1</sup> / <sub>2</sub>	3 <sup>1</sup> / <sub>2</sub>	1 <sup>1</sup> / <sub>4</sub>	1	2 <sup>5</sup> / <sub>8</sub>	1 <sup>3</sup> / <sub>4</sub>	2
S7	4000	2 <sup>1</sup> / <sub>32</sub>	7 <sup>1</sup> / <sub>2</sub>	3 <sup>3</sup> / <sub>4</sub>	9	5 <sup>5</sup> / <sub>8</sub>	4 <sup>1</sup> / <sub>2</sub>	3 <sup>3</sup> / <sub>8</sub>	1 <sup>1</sup> / <sub>4</sub>	3 <sup>5</sup> / <sub>8</sub>	2 <sup>1</sup> / <sub>8</sub>	3 <sup>1</sup> / <sub>8</sub>
S10	7000	2 <sup>5</sup> / <sub>32</sub>	10	6	12	3 <sup>3</sup> / <sub>4</sub>	5 <sup>1</sup> / <sub>2</sub>	1 <sup>1</sup> / <sub>2</sub>	1 <sup>1</sup> / <sub>2</sub>	5 <sup>1</sup> / <sub>2</sub>	2 <sup>1</sup> / <sub>2</sub>	4 <sup>3</sup> / <sub>4</sub>

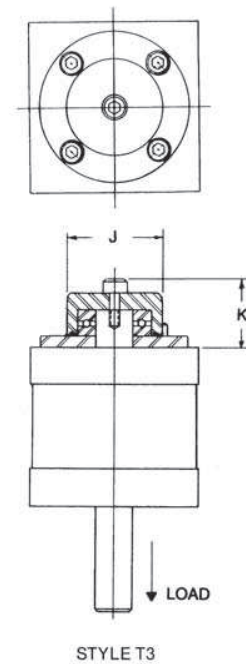
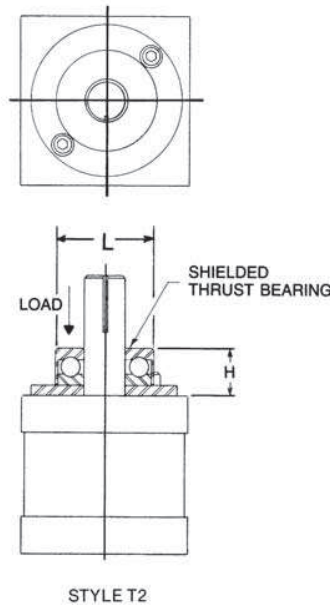
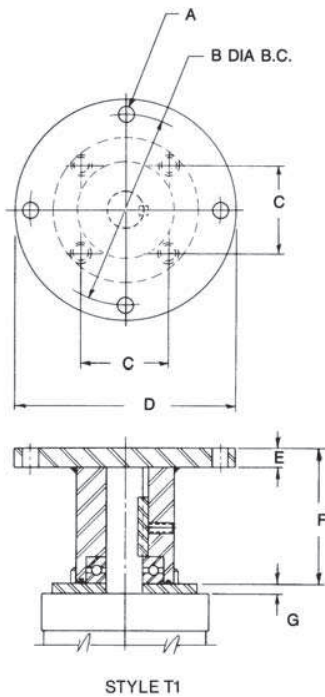

**Additional Options**

- Fluorocarbon Seals (V)
- Feedback Potentiometer (J) – Consult factory for limitations



# Electronic Sensors

Solid State, Reed and Proximity Sensors  
Feedback Packages

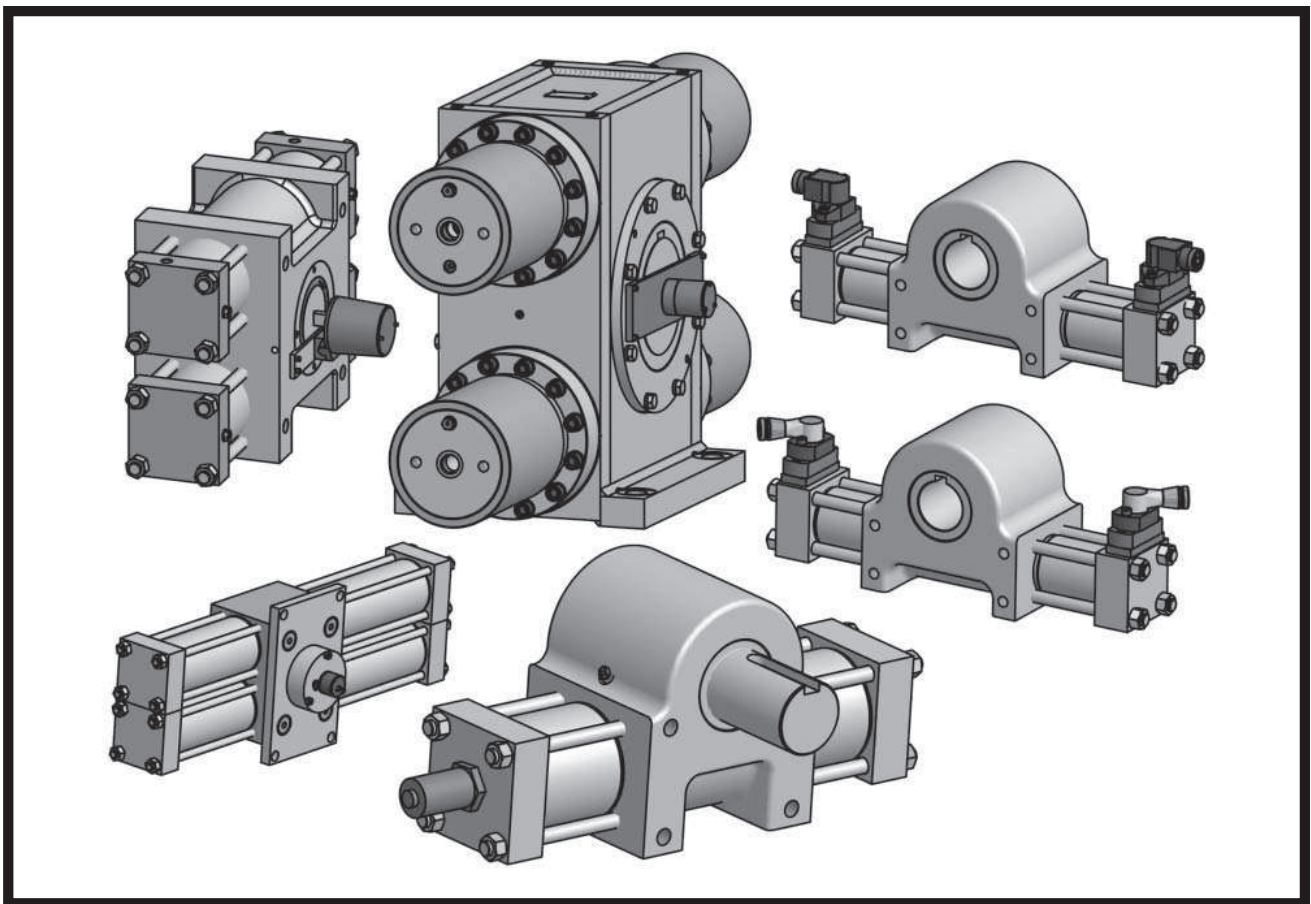

Sensors &  
Feedback

## Contents

Hall Effect Sensors .....	2
Reed Switches .....	3
Cordsets .....	4
Proximity Sensors .....	5
Feedback Packages .....	8



**Solid State (Hall Effect) Sensors**

**Part Numbers**

Model	PNP		NPN	
	With 6" Male Quick Connect	With 39" Potted-in Leads	With 6" Male Quick Connect	With 39" Potted-in Leads
10	SWH-1PC	SWH-1P	SWH-1NC	SWH-1N
15	SWH-1PC	SWH-1P	SWH-1NC	SWH-1N
20	SWH-2PC	SWH-2P	SWH-2NC	SWH-2N
25	SWH-2PC	SWH-2P	SWH-2NC	SWH-2N
32	SWH-2PC	SWH-2P	SWH-2NC	SWH-2N

Note: Switches with male quick connect option require female cordsets to be ordered separately. See page 4.

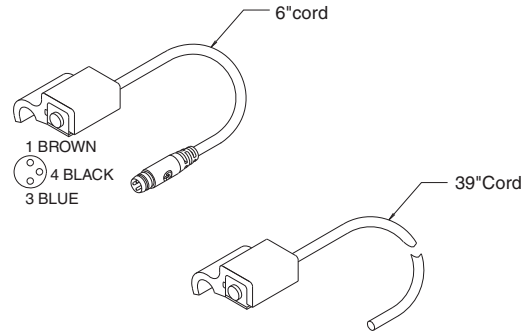

**Specifications**

Type ..... Solid State (PNP or NPN)  
 Switching Logic ..... Normally Open  
 Supply Voltage Range .. 6 - 30VDC  
 Current Output Range... Up to 100 mA at 5 VDC,  
 Up to 200 mA at 12 VDC and 24 VDC  
 Current Consumption .... 7 mA at 5 VDC, 15 mA at 12 VDC,  
 and 30 mA at 24 VDC  
 Switching Response ..... 1000 Hz Maximum  
 Residual Voltage ..... 1.5V Maximum  
 Leakage Current ..... 10uA Maximum  
 Breakdown Voltage ..... 1.8kVACrms for 1 sec., lead to case  
 Min. Current for LED ..... 1mA  
 Operating Temperature . 14 to 140°F (-10 to 60°C)  
 Enclosure Protection..... Meets IEC IP67, fully encapsulated  
 Lead Wire ..... 3 conductor, 24 gauge  
 Lead Wire Length ..... 39 in (1 m)  
 Vibration Resistance ..... 10-55 Hz, 1.5mm double amplitude

**WIRING CONNECTION**

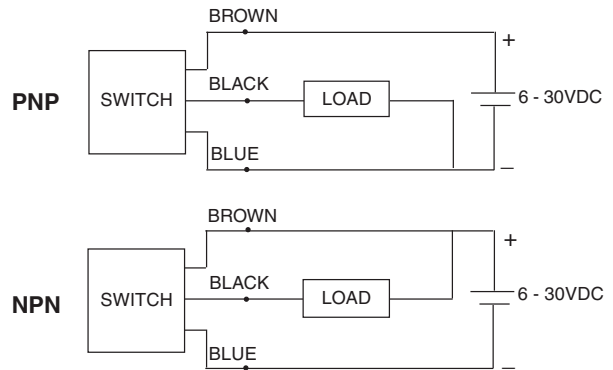

**PROTECTION CIRCUIT\***

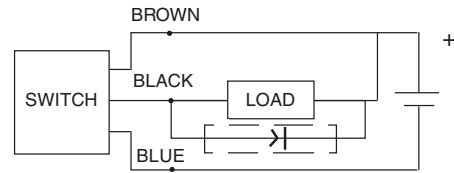

\* When connecting an inductive load (relay, solenoid valve, etc.), a protection circuit is recommended. Use a 100V, 1A diode. (NPN connection shown.)

**Reed Switches**

**Part Numbers**

Model	With 6" Male Quick Connect	With 39" Potted-in Leads
10	SWR-1C	SWR-1
15	SWR-1C	SWR-1
20	SWR-2C	SWR-2
25	SWR-2C	SWR-2
32	SWR-2C	SWR-2

Note: Switches with male quick connect option require female cordsets to be ordered separately. See page 4.

**Specifications**

- Switching Logic ..... Normally Open
- Voltage Rating ..... 85-125 VAC or 6-30 VDC\*
- Power Rating ..... 10 Watts AC or DC/Resistive Load  
 5 Watts AC or DC/Inductive Load
- Switching Current Range . 10-200 mA/Resistive Load  
 (PC, Sequencer)  
 10-100 mA/Inductive Load (Relay)
- Switching Response ..... 300 Hz Maximum
- Breakdown Voltage ..... 1.8kVACrms for 1 sec., lead to case
- Min. Current for LED ..... 18mA
- Operating Temperature .... 14 to 140°F (-10 to 60°C)
- Enclosure Protection ..... Meets IEC IP67, fully encapsulated
- Lead Wire ..... 2 conductor, 22 Gauge
- Lead Wire Length ..... 39 in (1 m)
- Vibration Resistance ..... 10-55 Hz, 1.5mm double amplitude

\* Polarity is restricted for DC operation  
 (+) to White  
 (-) to Black  
 If these connections are reversed the contacts will close, but the LED will not light.

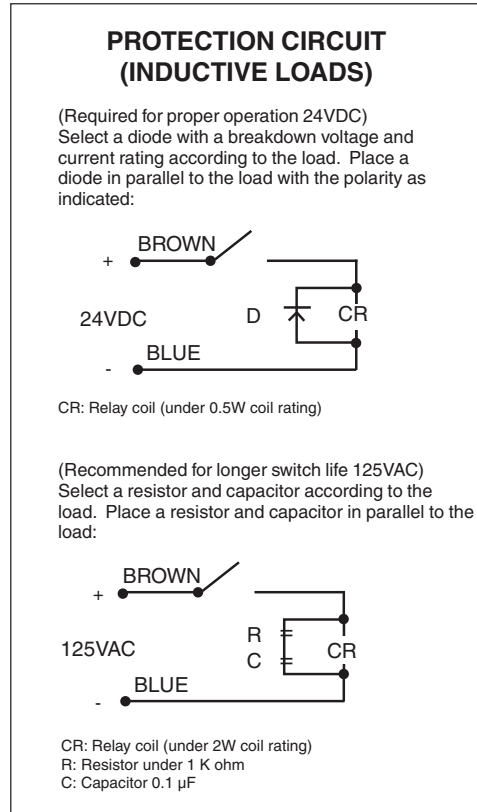

**Sensors & Feedback**

**Cordsets**

**Sensor Accessories**

**8mm Cordset with Female Quick Connect**

A female connector is available for all sensors with the male 8mm quick connect option. The male plug will accept a snap-on or threaded connector. Cordset part numbers are listed below:

Cable Length	Threaded Connector	Snap-On Connector
5 meters	086620T005	086620S005
2 meters	086620T002	086620S002

**Snap-On Straight Connector**

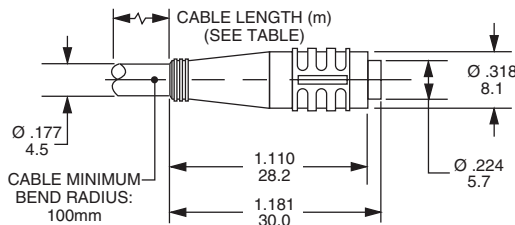

**Cordset Specifications:**

- Connector: Oil resistant polyurethane body material, PA 6 (Nylon) contact carrier, spacings to VDE 0110 Group C, (150 AC/DC)
- Contacts: Gold plated beryllium copper, machined from solid stock
- Coupling Method: Snap-Lock or chrome plated brass nut
- Cord Construction: Oil resistant black PUR jacket, non-wicking, non-hygroscopic, 300V. Cable end is stripped and tinned.
- Conductors: Extra high flex stranding, PVC insulation
- Temperature: -40 to 194°F (-40 to 90°C)
- Protection: NEMA 1, 3, 4, 6P and IEC 1P67
- Cable Length: 6.56 ft (2m) or 16.4 ft (5m)

**Threaded Straight Connector**

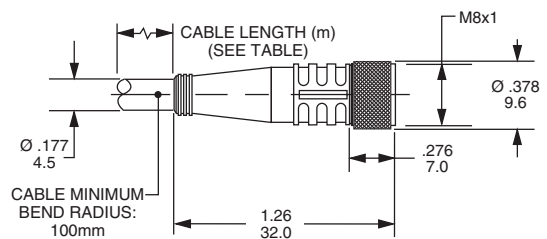

**12mm Cordset with Female Quick Connect**

M12 Straight Connector	
Cable Length	Part Number
5 meters	9126487205
2 meters	9126487202

A female connector is available for all sensors with the male 12mm quick connect option. The cordsets are available with a right angle or straight connector. Cordset part numbers are listed above.

**Cordset Specifications:**

- Connector: Polyvinylchloride (PVC) body material, PVC contact carrier, spacing to VDE 0110 Group C, (250VAC / 300VDC)
- Contacts: Gold Plated Copper Tin (CuSn), stamped from stock.
- Coupling Method: Threaded nut: Chrome plated brass.
- Cord Construction: PVC non-wicking, non-hygroscopic, 250VAC / 300VDC. Cable end is stripped.
- Conductors: Extra high flex stranding with PVC insulation
- Temperature: -13°F to 158°F (-25°C to 70°C)
- Protection: NEMA 1, 3, 4, 6P and IEC 1P67
- Cable Length: 6.56 ft (2m) or 16.4 ft (5m)

M12 Right Angle Connector	
Cable Length	Part Number
5 meters	9126487305
2 meters	9126487302

**Straight Connector**

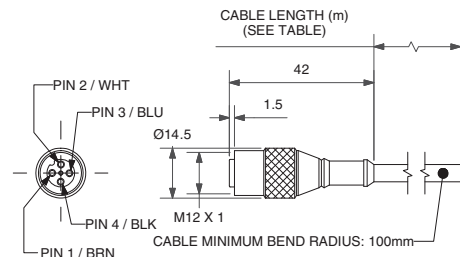

**Right Angle Connector**

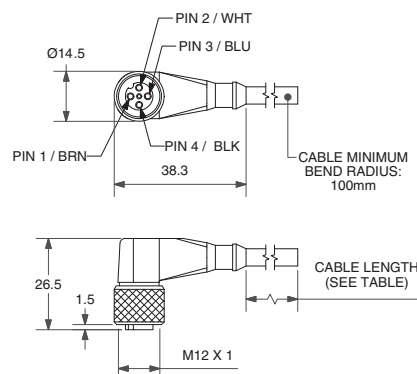



**EPS 7 & 6 Sensors**

Connector housing is rotatable 360°  
To rotate, loosen screws, position the connector housing and secure screws.

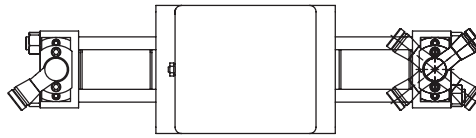

Model Series	Cylinder Series	C <sub>max</sub>
LTR	2L	1.05"
HTR	2H	1.75"

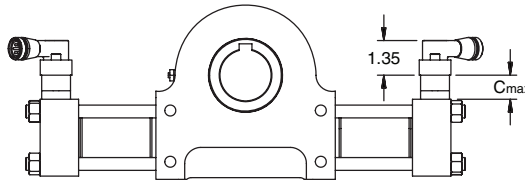

**Series and Parallel Wiring**

When Parker EPS-6 or 7 proximity switches are used as inputs to programmable controllers the preferred practice is to connect each switch to a separate input channel of the PC. Series or parallel operations may then be accomplished by the internal PC programming.

Parker EPS-6 or 7 switches may be hard wired for series operation, but the voltage drop through the switches (see specifications) must not reduce the available voltage below what is needed to actuate the load.

Parker EPS-6 or 7 switches may also be hard wired for parallel operation. However, the leakage current of each switch will pass through the load. The total of all leakage currents must not exceed the current required to actuate the load. In most cases, the use of two or more EPS-6 or 7 switches in parallel will require the use of a bypass (shunt) resistor.

**Connector Pin Numbering**

**3-Pin Mini**

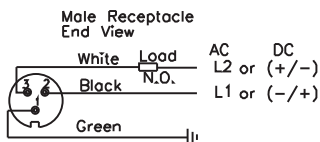

**5-Pin Mini**

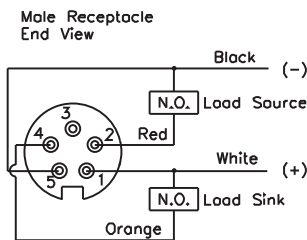

**Sensors & Feedback**

**Specifications**

Style:	EPS-7	EPS-6
<b>Description:</b>	Economical, General Purpose, 2 wire device, primarily for AC applications, not suitable for 24 VDC applications.	Economical, General Purpose, 3-wire, DC sensor, dual output: sinking and sourcing
<b>Supply Voltage:</b>	20 to 250 VAC/DC	10 to 30 VDC
<b>Load Current, min:</b>	8 mA	NA
<b>Load Current, max:</b>	300 mA	200 mA
<b>Leakage Current:</b>	1.7 mA, max.	10 micro amps max.
<b>Voltage Drop:</b>	7 V, max.	2 VDC max.
<b>Operating Temperature:</b>	-14° to +158° F	-14° to +158° F
<b>Sensor Type:</b>	Inductive proximity	Inductive proximity
<b>Connection:</b>	3 pin mini	5 pin mini
<b>Enclosure Rating:</b>	IEC IP67	IEC IP67
<b>LED indication:</b>	Yes	Yes
<b>Short Circuit Protection:</b>	Yes	Yes
<b>Weld Field Immunity:</b>	Yes	Yes
<b>Output:</b>	2 wire, Normally Open with leakage current	Dual output: DC Sinking and DC Sourcing, user selectable via wiring
<b>Approvals/Marks:</b>	CE, UL, CSA	CE, UL, CSA
<b>Make/Break Location:</b>	0.125" from end of stroke, typical. Tolerance is 0/-0.125"	
<b>Wiring Instructions:</b>	Pin 1: AC Ground (Green) Pin 2: Output (Black) Pin 3: AC Line (White)	Pin 1) +10 to 30 VDC (White) Pin 2) Sourcing Output (Red) Pin 3) Grounded (not connected or required) Pin 4) Sinking Output (Orange) Pin 5) DC Common (Black)
<b>Connector:</b> Cable: 6' Cable: 12' Cable: 6', Right Angle	085355-0006 085355-0012 087547-0006	085917-0006 085917-0012 —

**Part Numbers**

Proximity Sensor	EPS-7	EPS-6
1.25" Probe	1488970125	1488960125
2.06" Probe	1488970206	1488960206
2.875" Probe	1488970288	1488960288
4.562" Probe	1488970456	1488960456

**EPS 7**

**Connectors**

The male quick disconnect on the Parker EPS 7 is a Brad Harrison 40909 connector.

Female connects must be purchased with one of the following cable lengths.

Cable Length	Parker Part No.	
	Automotive	Standard
3'	085356003	0853550003
6'	085356006	0853550006
9'	085356009	—
12'	0853560012	0853550012

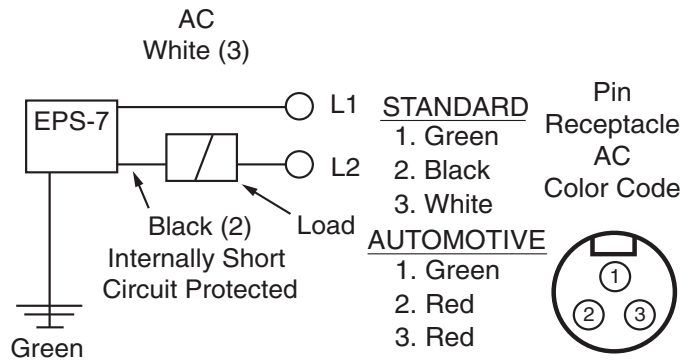

**EPS 6**

**Connectors**

The male quick disconnect on the Parker EPS-6 is a Brad Harrison 41310 connector.

**Plug Pin and Cable Identification**

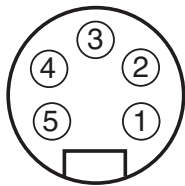

- 1) +10 to 30 VDC (White)
- 2) Source (Red)
- 3) Grounded not connected nor required
- 4) Sink (Orange)
- 5) Common (Black)

Cable Length	Parker No.
3	085917 0003
6	085917 0006
12	085917 0012

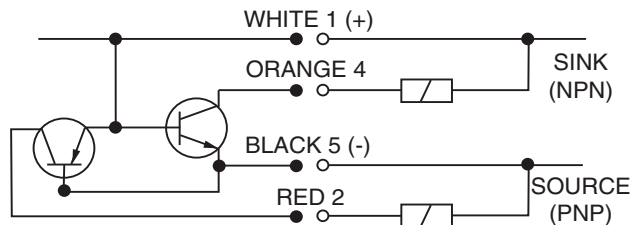

LED Function	'Ready'	'Target'
Power Applied (No Target)	ON	OFF
Target Present	OFF	ON
Short Circuit Condition	FLASH	FLASH

**Sensors & Feedback**

**Selection Guide**

Feedback packages are available for LTR, HTR, M Series and Tork-Mor actuators. The feedback potentiometer may be ordered as part of the model code (Code J). Other options must be ordered separately. See the following pages for specifications.

Model		Temposonics LDT Feedback	Teknar Linear Potentiometer	Precision Feedback Potentiometer	Resolver
Single Rack	Double Rack				
LTR101	LTR102	—	—	Code J	Code H
LTR151	LTR152	—	—	Code J	Code H
LTR201	LTR202	—	—	Code J	Code H
LTR251	LTR252	—	—	Code J	Code H
LTR321	LTR322	—	—	Code J	Code H
HTR.9	HTR1.8	—	—	Code J	Code H
HTR3.7		—	—	Code J	Code H
	HTR7.5	Special	Special	Code J	Code H
HTR5		—	—	Code J	Code H
	HTR10	Special	Special	Code J	Code H
HTR15		Special	Special	Code J	Code H
	HTR30	Special	Special	Code J	Code H
HTR22		Special	Special	Code J	Code H
	HTR45	Special	Special	Code J	Code H
HTR75		Special	Special	Code J	Code H
	HTR150	Special	Special	Code J	Code H
HTR300		Special	Special	Code J	Code H
	HTR600	Special	Special	Code J	Code H
75M		Special	Special	Code J	Code H
	150M	Special	Special	Code J	Code H
300M		Special	Special	Code J	Code H
	600M	Special	Special	Code J	Code H
	1,000M	Special	Special	Code J	Code H
	1,500M	Special	Special	Code J	Code H
	2,000M	Special	Special	Code J	Code H
	3,000M	Special	Special	Code J	Code H
	4,000M	Special	Special	Code J	Code H
	5,000M	Special	Special	Code J	Code H
	6,000M	Special	Special	Code J	Code H
	7,000M	Special	Special	Code J	Code H
	8,000M	Special	Special	Code J	Code H
	9,000M	Special	Special	Code J	Code H
	10,000M	Special	Special	Code J	Code H
	15,000M	Special	Special	Code J	Code H
	20,000M	Special	Special	Code J	Code H
	25,000M	Special	Special	Code J	Code H
	30,000M	Special	Special	Code J	Code H
	40,000M	Special	Special	Code J	Code H
	50,000M	Special	Special	Code J	Code H
33S	33DS	—	—	Code J	Code H
42S	42DS	—	—	Code J	Code H
44S	44DS	—	—	Code J	Code H
46S	46DS	—	—	Code J	Code H
74S	74DS	—	—	Code J	Code H
77S	77DS	—	—	Code J	Code H
105S	105DS	—	—	Code J	Code H
108S	108DS	—	—	Code J	Code H
1012S	1012DS	—	—	Code J	Code H

**PRECISION FEEDBACK POTENTIOMETER PACKAGE (J)**

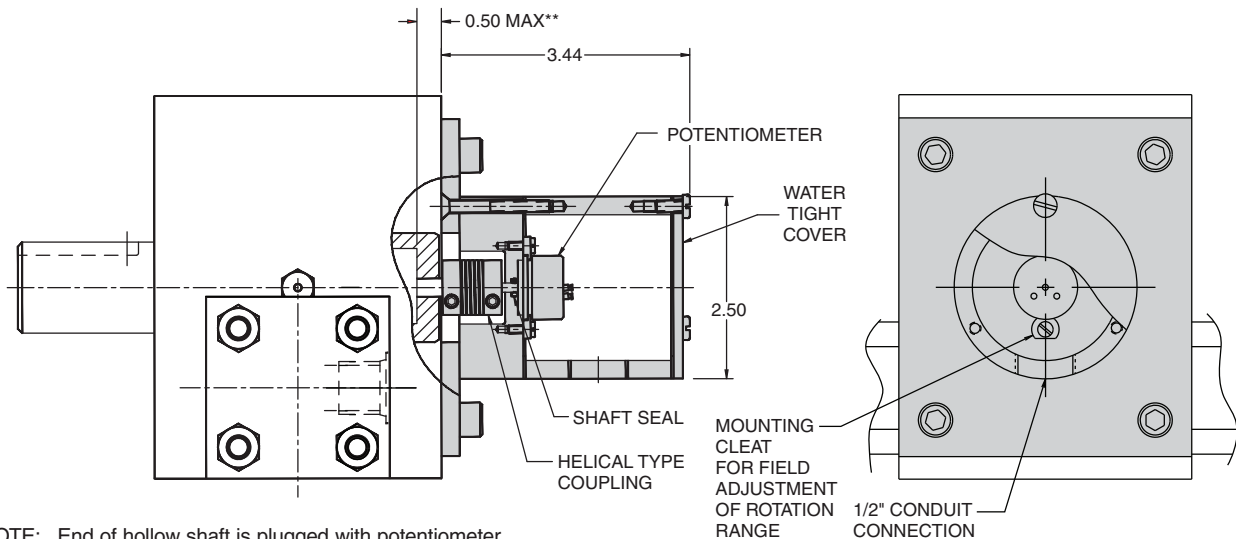

**\*\*NOTE:** End of hollow shaft is plugged with potentiometer drive shaft. Mating shaft engaged length must clear plug thickness.

**APPLICATION:**

The potentiometer option is an analog feedback device designed for use on a wide variety of applications that utilize closed-loop feedback to achieve accurate position, velocity, or motion control. The potentiometer option can also be used on open-loop systems as a continuous, infinite position monitoring device.

**OPERATION:**

A potentiometer is a variable resistor. There are three electrical terminals on the potentiometer - two on opposite ends of a fixed conductive plastic element (terminals 1 and 3, see electrical schematic on the right) and one attached to the "wiper" that moves along the conductive element as the shaft rotates (terminal 2). As the potentiometer shaft rotates, resistance between terminal 2 and terminals 1 and 3 changes.

Because the resistance of the potentiometer is linear ( $\pm .1\%$ ), when a fixed voltage level is supplied across terminals 1 and 3, shaft position can be determined by reading the output voltage at terminal 2. By measuring the rate of change in voltage at terminal 2, rotational velocity can be determined. To determine actuator position or velocity, the potentiometer shaft is connected to the actuator shaft via a flexible coupling. The potentiometer is enclosed in a water tight enclosure for resistance to dirty environments.

**ORDERING INFORMATION:**

Specify in model code.

**POTENTIOMETER SPECIFICATIONS:**

- Potentiometer: 7/8" diameter single turn precision servo-mount with conductive plastic element
- Resistance: 10K ohms
- Resistance Tolerance:  $\pm 10\%$
- Linearity:  $\pm 1\%$
- Resolution: Essentially infinite
- Effective electrical angle:  $340^\circ \pm 3\%$
- Power rating: 70°C - 1 watt  
125°C - 0 watt
- Temperature Rating: - 40°C to + 125°C
- Backlash: 0.1° max.
- Rotational life: 20,000,000 rev.
- Terminal: Rear, turret style
- Available on: Rack & Pinion\* - LTR Series  
HTR Series  
M Series  
Vane - Torq-Mor Series
- Maximum Rotation: 360° mechanical

• Electrical Schematic:

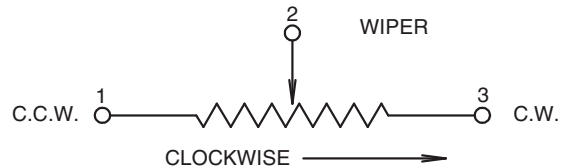

**NOTE:**

- \*1. Rack and pinion actuators have a small amount of backlash – consider before applying.
2. Electrohydraulic options and operation may affect other actuator components such as seals, bearings, etc. Consult your local representative for additional information.

**Sensors & Feedback**

**PRECISION RESOLVER FEEDBACK PACKAGE (H)**

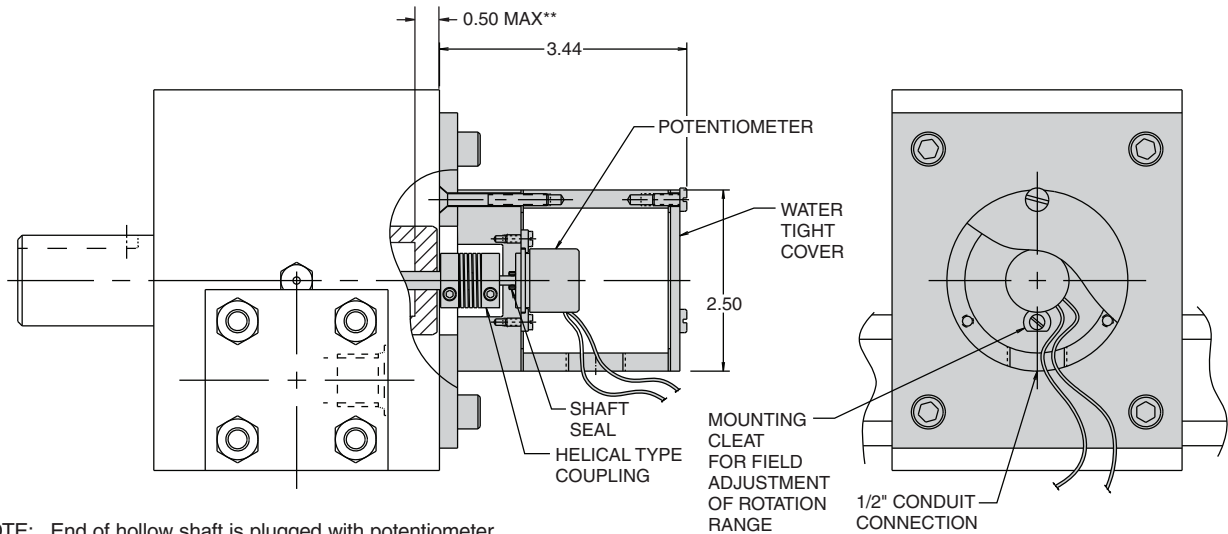

**\*\*NOTE:** End of hollow shaft is plugged with potentiometer drive shaft. Mating shaft engaged length must clear plug thickness.

**APPLICATION:**

The resolver option is a precision analog feedback device designed for use on a wide variety of applications that utilize closed-loop feedback to achieve accurate position, velocity, or motion control. The resolver option can also be used on open-loop systems as a continuous, infinite position monitoring device.

**OPERATION:**

A resolver is a brushless rotary synchronous transformer which eliminates wiping contact and provides higher response and accuracy. A voltage and frequency is applied across the primary coil; changes in shaft position cause a proportional change in the secondary winding. Measuring the rate of change also provides velocity. To determine actuator position or velocity, the resolver shaft is connected to the actuator shaft via a flexible coupling. The resolver is enclosed in a water tight enclosure for resistance to dirty environments.

**ORDERING INFORMATION:**

Actuators can be supplied as complete packages as specified in the model code, or just the enclosure for the mounting of a customer supplied resolver can be provided. Consult the factory or your local representative for specific application and ordering information.

**RESOLVER SPECIFICATIONS:**

- Resolver: 11D servo-mount, brushless synchro
- Input Voltage: 7.5 volts
- Input Frequency: 4000 Hz
- Input Current: 13.5 mA (max)
- Input Power: 60 mW
- Output Voltage: 4 volts
- Phase Shift: -2°
- Sensitivity: 70 mV/°
- DC Rotor Resistance: 15 ohms
- DC Stator Resistance: 19 ohms
- Total Null Voltage: 20 mV
- Accuracy (Maximum error): 7 minutes\*
- Leads: #28 AWG, 12 inches long
- Available on:
  - Rack & Pinion\* - LTR Series  
HTR Series  
M Series
  - Vane - Torq-Mor Series

**NOTE:**

- \*1. Rack and pinion actuators have a small amount of backlash – consider before applying.
2. Electrohydraulic options and operation may affect other actuator components such as seals, bearings, etc. Consult your local representative for additional information.

**LINEAR POTENTIOMETER FEEDBACK PACKAGE (Oildyne Teknar)**

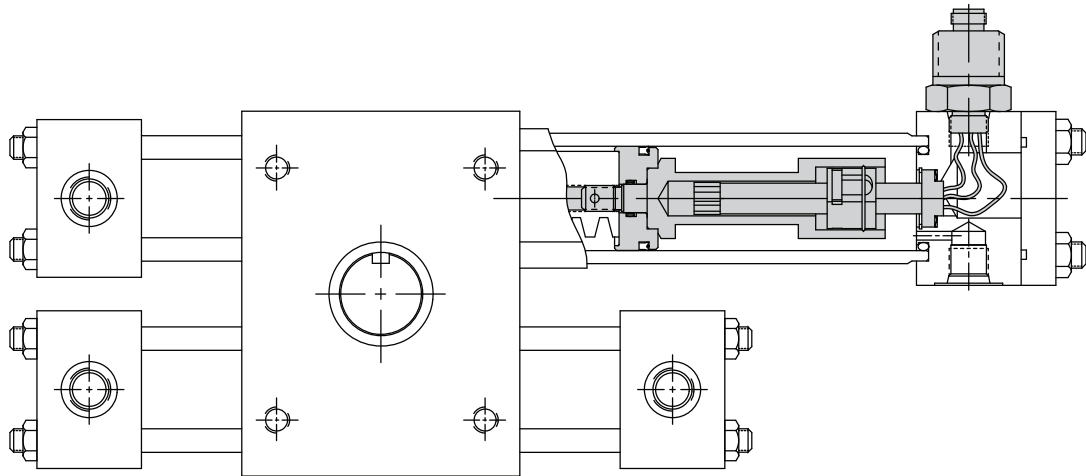

**APPLICATION:**

The linear potentiometer option is an analog feedback device typically used for rotary actuator rotations exceeding 340°, or where a standard rotary potentiometer cannot be connected to the actuator shaft. Applications for this device include closed loop feedback to achieve accurate position, velocity, or motion control. This option can also be used on open-loop systems as continuous, infinite position monitoring device.

**OPERATION:**

A potentiometer is a variable resistor. There are three electrical terminals on the potentiometer - two on opposite ends of a fixed conductive plastic element (terminals 1 and 3, see electrical schematic on the right) and one attached to the "wiper" that moves along the conductive element with the piston and rack. As the wiper moves along the element, resistance between terminal 2 and terminals 1 and 3 changes.

Because the resistance of the potentiometer is linear ( $\pm .1\%$ ), when a fixed voltage level is supplied across terminals 1 and 3, shaft position can be determined by reading the output voltage at terminal 2. By measuring the rate of change in voltage at terminal 2, rotational velocity can be determined. Since the linear potentiometer is enclosed in the actuator itself, it is safe for operation in dirty or wet environments.

**ORDERING INFORMATION:**

Consult the factory or your local representative for specific application and ordering information.

**LINEAR POTENTIOMETER SPECIFICATIONS:**

- Potentiometer: Calibrated conductive film with low resistance wiper carriage.
- Resistance: Approx. 1 K ohm per inch of stroke
- Resistance Tolerance:  $\pm 20\%$
- Linearity: 0.1% of full stroke
- Voltage: 5 - 50vdc
- Resolution: Essentially infinite\*
- Repeatability: 0.001\*
- Power rating: 70°C - 1 watt/cm<sup>2</sup>  
125°C - 0 watt/cm<sup>2</sup>
- Temperature Rating: -55°C to 125°C
- Pressure Rating: 3,000 psi
- Terminal: 3 pin micro connector
- Available on:  
Rack & Pinion\* - HTR Series  
M Series

• Electrical Schematic:

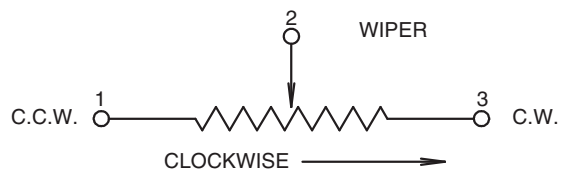

**NOTE:**

- \*1. Rack and pinion actuators have a small amount of backlash – consider before applying.
2. Electrohydraulic options and operation may affect other actuator components such as seals, bearings, etc. Consult your local representative for additional information.

**Sensors & Feedback**

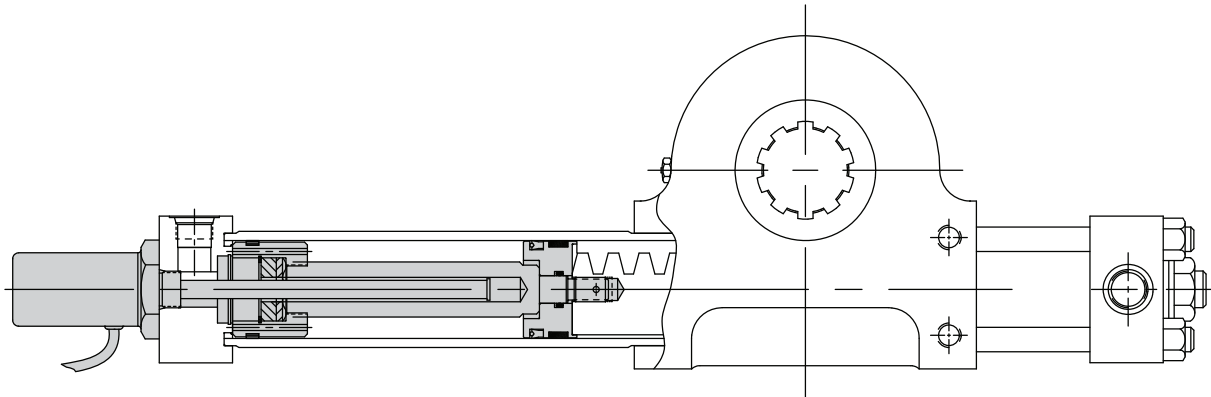
**LDT FEEDBACK PACKAGE (MTS Temposonics)****APPLICATION:**

The linear displacement transducer (LDT) option provides digital feedback of the rack position via interaction between two magnetic fields. The LDT option is recommended for applications where rotation exceeds 340°, or where a standard rotary potentiometer or resolver cannot be connected to the actuator output shaft. Applications for this device include closed loop feedback to achieve accurate position, velocity, or motion control. This option can also be used on open-loop systems as a continuous, infinite position monitoring device.

**OPERATION:**

The LDT utilizes two magnets, a permanent one located on the piston, the other is a magnetic pulse generated by a current pulse along a wire inside a waveguide tube. The interaction between the fields produces a strain pulse which travels down the waveguide tube and is sensed by a coil at the end of the device. Position and velocity of the permanent magnet is pinpointed by measuring the lapsed time between the launching of the current pulse and the arrival of the strain pulse. An interface box converts this information to a usable output form, either digital or analog.

**ORDERING INFORMATION:**

Actuators can be provided as complete packages or with drilling and mounting for customers purchased LDTs. Consult the factory or your local representative for specific application and ordering information.

**LDT SPECIFICATIONS:**

- Linearity:  $\pm 0.05\%$  of full stroke (min.  $\pm 0.002$  in.)\*
- Repeatability:  $\pm 0.0001$  in.\*
- Temperature Coefficient (probe):  $<10$  ppm/°F
- Temperature Coefficient (electronics box):
  - Digital:  $<10$  ppm/°F
  - Analog: 55 ppm/°F
- Resolution\*:
  - Digital: .004, .002, .001 or .0005 available\*
  - Analog: Stepless continuous output\*
- Output:
  - Digital: Absolute, TTL compatible, parallel or serial
  - Analog: -10 to +10 Vdc and 20mA range
- Operating Temperature:
  - Digital: 0° to 150°F
  - Analog: 35° to 150°F
- Hysteresis: .0008 in.\*
- Available on:
  - Rack & Pinion\* - HTR Series
  - M Series

**NOTE:**

- \*1. Rack and pinion actuators have a small amount of backlash – consider before applying.
- \*2. Electrohydraulic options and operation may affect other actuator components such as seals, bearings, etc. Consult your local representative for additional information.



# Rotary Actuators

List of Symbols .....	2
Introduction .....	3
Types of Rotary Actuators .....	3
Table 1: Rotary Actuator Applications .....	4
Table 2: Rotary Actuator Comparison Chart .....	7
Calculating Torque Requirements .....	8
Demand Torque Examples (English) .....	9
Table 3: Mass Moments of Inertia .....	10
Applied Torque Examples .....	11
Sizing Rotary Actuators .....	19
Minimum Possible Rotary Actuator Volume (S.I. Units) .....	21
Coverting Volume per Radian to Volume Displacement (S.I. Units) .....	21
Minimum Possible Rotary Actuator Volume (English Units) .....	22
Coverting Volume per Radian to Volume Displacement (English Units) .....	22
Table 4: Converting Vs to V .....	24
Calculating Required Pump Flow .....	25
Circuit Recommendations .....	28
Installation Instructions and Options .....	30

Reprinted from Bul. 0292-B1 Design Engineer's Handbook, Vol. 1 - Hydraulics.

Copyright© 2001 by Parker Hannifin Corporation, all rights reserved. No part of this book may be reproduced, stored in a retrieval system, or transmitted, in any form or by any means: electronic, mechanical, photocopying, recording or otherwise without prior permission of the publisher.

Printed in The United States of America

A	Area	$T_C$	Cushion torque
d	Diameter	$T_D$	Demand torque
F	Force	$T_f$	Friction torque
$g_c$	Gravitational constant (386 in/sec <sup>2</sup> )	V	Volume displacement
I	Mass mount of inertia	$V_s$	Specific Volume in terms of in <sup>3</sup> per radian
m	Mass	W	Weight
P	Pressure	x	Distance or position
$P_C$	Average cushion pressure	$\alpha$	Angular acceleration
$P_r$	Relief valve pressure	$\mu$	Coefficient of friction
Q	Volumetric flow rate	$\theta$	Angular displacement or rotation
r	Radius	$\omega$	Angular velocity
$r_b$	Bearing radius	$\omega_o$	Angular velocity at time = 0
t	Time	$\omega_t$	Angular velocity at time = t
T	Torque		
$T_\alpha$	Angular acceleration torque		
$T_{\alpha^*}$	Angular deceleration torque		

# Rotary Actuators

## Introduction

A rotary actuator is the most compact device available for producing torque from hydraulic or pneumatic pressure. A self-contained unit, it is usually limited to one revolution or less and can provide oscillating motion as well as high and constant torque. Figure 1 shows the standard symbol for pneumatic and hydraulic rotary actuators.

There are many types of rotary actuators, each with design advantages as well as compromises. The three most commonly used are rack and pinion, vane, and helical. These type actuators are compared in Table 3 on page 7.

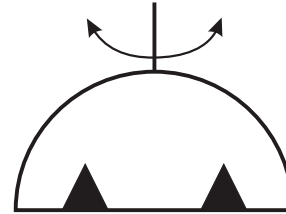

Figure 1 Hydraulic rotary actuator symbol

## Types of Rotary Actuators

### Rack and Pinion

Rack and pinion actuators consist of a housing to support a pinion which is driven by a rack with cylinder pistons on the ends (see Fig. 2). Theoretical torque output  $T$ , is the product of the cylinder piston area  $A$ , operating pressure  $P$ , and the pitch radius of the pinion  $r_p$ .

Equation 1)  $T = PA r_p$

Single, double, or multiple rack designs are possible and overall efficiencies for rack and pinion units average 85 to 90%. Because standard cylinder components can be used to drive the rack, many standard cylinder features can be incorporated into rack and pinion actuators, such as cushions, stroke adjusters, proximity switches, and special porting. Additionally, virtually leakproof seals will allow the actuator to be held in any position under load.

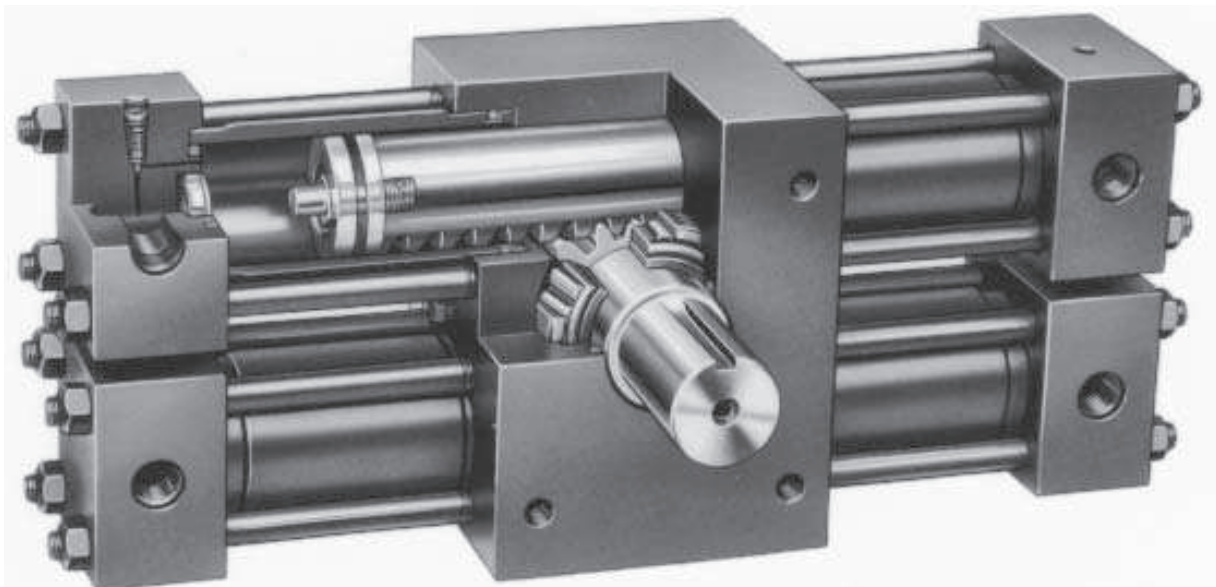

Figure 2 Rack and pinion type rotary actuator, double rack design

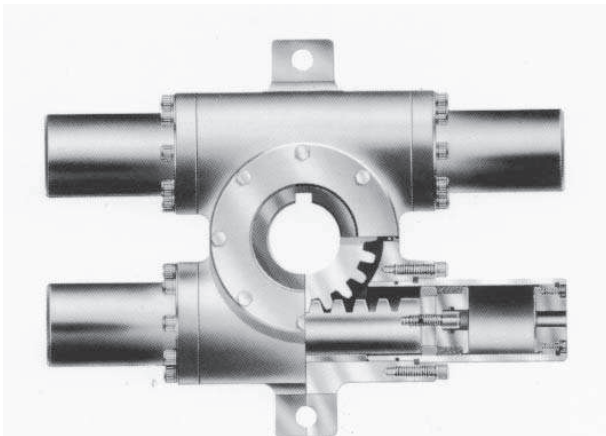

Figure 3 Mill type actuator design

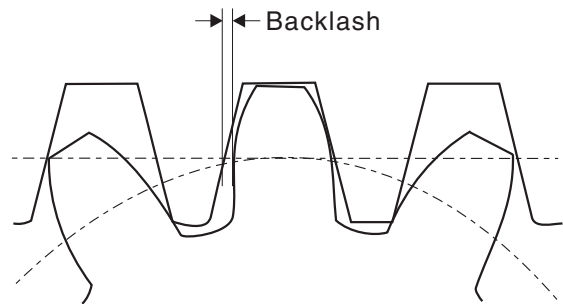

Figure 4 Gear backlash affects position accuracy

**NOTE: Some systems require a mechanical locking device for safety reasons, or for holding loads over extended periods of time.**

Both tie-rod and mill cylinder type (Fig. 3) constructions are available, and most types allow for service of all pressure containing seals without removing the unit from its mounting.

Rack and pinion actuators cover the widest range of torque, from 0.9 N•m (8 lb. in.) pneumatic to over 5,630,630 N•m (50,000,000 lb. in.) in hydraulic units. Because of their construction, they are not limited to  $0.2\pi$  rad (360 degrees) of rotation and can easily be built to  $10\pi$  rad (1800 degrees) (five revolutions). The majority of rack and pinion style actuators are sold for hydraulic service, generally 34 to 207 bar (500 to 3000 psi).

Position repeatability in rack and pinion actuators is affected by the inherent backlash found in any gear arrangement. Backlash is the amount by which the width of a tooth space exceeds the thickness of the mating tooth and can be as much as  $\pi/360$  (0.5 degrees) on smaller size units (Fig. 4). It should be noted, however, that this backlash can be reduced to almost nothing by preloading the rack into the pinion, but efficiencies will suffer to overcome the added friction.

Because the load ratings of the bearings used to support the pinion are large in comparison to the internal loading of the unit, extra bearing capacity is usually available. This can eliminate the need for machine support bearings, or handle overhung and thrust loads which would be detrimental to other types of rotary actuators. In other applications, a hollow pinion is used, which eliminates the need for a coupling and support brackets because the actuator can be mounted directly onto the input shaft.

### Table 1: Rotary Actuator Applications

**General Industry**

Camming, indexing, clamping, positioning, tensioning, braking, tilting, etc.

**Material Handling**

Switching conveyors, turning and positioning container clamps on lift trucks, tensioning and guiding, operating valves, braking, lifting

**Robotics**

Rotation and positioning

**Marine**

Opening and closing hatches, swinging cargo handling gear, opening and closing fire and collision bulkhead doors, operating large valves of all types, positioning hydrofoils, steering control

**Steel**

Upending coils, turnstiles, rollover devices, tilting electric furnaces, indexing transfer tables, charging furnaces

In general, rack and pinion actuators have a thin profile, but are not as physically compact as other styles of rotary actuators, and are usually slightly more expensive than vane actuators of equivalent torque output.

## Vane

Vane style actuators consist of one or two vanes attached to a shaft (called the rotor), which is assembled into a body, and then held in place by two heads (Fig. 5). Rotation of single vane units is generally limited to 4.9 rad (280 degrees) by a fluid barrier (called a stator). Double vane units are limited to 1.7 rad (100 degrees) because two stators are required at opposite ends. The operating medium (air or oil) is ported across the shaft in double vane style actuators to eliminate the need for four ports. Fluid pressure acting on the exposed vane surface produces an output torque, shown in Equation 2:

$$\text{Equation 2) } T = LWP$$

Where the torque  $T$  is equal to the product of the vane length  $L$ , times the vane width  $W$ , times the system pressure  $P$ , times the radial distance  $r$  from the center of the rotor to the vane pressure center. Of course, a double vane style actuator will have twice the area of a single vane style actuator, and therefore twice the torque.

Available industry sizes range from a minimum of 1.4 N•m (12 lb. in.) with small pneumatic actuators to a maximum of 84460 N•m (750,000 lb. in.) with high pressure hydraulic actuators.

Vane style actuators have no backlash, but because of the seal configuration, cannot hold position without pressure being applied. The vane seal typically has sharp corners to seal in the body/head interface. Since this corner cannot be sealed completely, there is always a slight bypass flow. There is additional bypass flow in the shoulder area of the vane, so

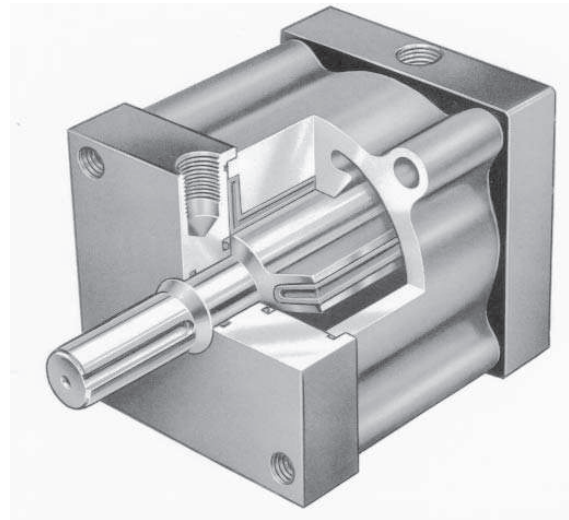

Figure 5 Vane type rotary actuator

even rounding the vane at the top does not completely eliminate leakage. Vane actuators require external stops to prevent damage to the vane and stator, especially for high inertia and high speed applications.

Vane actuators are very compact devices and are typically less expensive than rack and pinion units of equivalent torque and pressure. Units are available with and without external shaft load capacity.

Vane actuators can be segmented into three general product lines:

- 1) Small pneumatic actuators for small parts handling, fixturing, etc.
- 2) 69 bar (1000 psi) hydraulic actuators for machine tool, automotive equipment, and transfer lines.
- 3) 207 bar (3000 psi) actuators for the mobile equipment industry.

**Introduction**

**Helical**

Helical actuators consist of a piston sleeve, which functions similarly to a cylinder piston, and a rotating output shaft encased in a cylinder type housing (See Fig. 7). The linear motion in the piston sleeve produces rotary motion of the output shaft through the male helix cut on the shaft and a fixed helical nut. The torque output is proportional to the helix angle, system pressure, piston area, and the mean pitch radius of the helical shaft.

Helix designs provide maximum torque output for the smallest possible cross section. Double helix designs are also available to reduce the length of the unit or double the torque output.

Helical units are generally the most expensive rotary actuators but also the most compact. They do have backlash and can be made self-locking with special helix designs. Helical units can be hydraulically or pneumatically operated and are available from 2.3 to 450,451 N•m (20 lb. in. to 4,000,000 lb. in.) of torque.

**Helical Type Actuators**

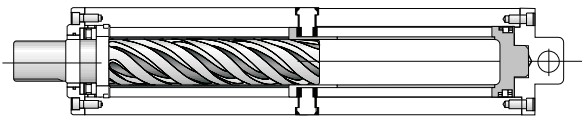

Figure 7a Initial position

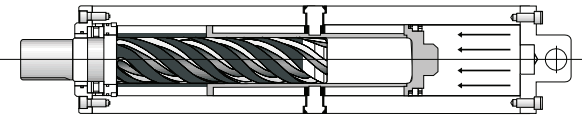

Figure 7b Pressure moves the sleeve causing the helix to rotate.

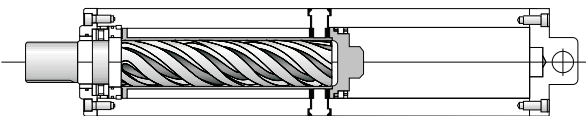

Figure 7c Final position

Table 2: Rotary Actuator Comparison Chart

Feature	Rack & Pinion	Vane	Helical
Load holding ability	Leakproof cylinder seals allow holding of load in any position.	Square vane seals and shoulder seals always have slight bypass flow.	Leakproof cylinder seals will allow holding of load in any position.
Positioning	Inherent backlash of rack and pinion cause position tolerance up to ½°.	Zero backlash allows for exact positioning anywhere in the rotation.	Some backlash, but can be made locking with special helix designs.
Efficiency (hydraulic)	90% is average	75-80% is average	60% is average
Stops	External stops usually not required.	Internal stops available for some light duty applications; majority of applications require positive external stops.	External stops usually not required.
Cushions	Standard cylinder cushions be used.	Typically no cushions available. Parker HRN Series offers these.	Consult manufacturer
Size	Thin profile but larger overall space and weight requirements	Very compact, especially cross section	The most compact cross section for a given torque
Maintenance	Maintenance of pressure seals possible without complete disassembly of unit.	Maintenance of vane requires disassembly of unit.	Maintenance of seals requires disassembly of unit.
Mounting	Mounting styles include lug, foot, face, base, flange or shaft mounting with hollow pinion.	Mounting styles include base, foot, face or flange mounting.	Mounting styles include foot, flange or body mounting.
Operating Medium	Air or hydraulic operation	Air or hydraulic operation	Air or hydraulic operation
Available Rotation	90°, 180° and 360° standard, specials to 1800°	280° maximum single vane unit, 100° maximum double vane unit	Consult manufacturer; specials made to order
Price	Generally more expensive than equivalent torque vane units	Generally less expensive than equivalent torque rack and pinion units	Generally much more expensive than equivalent rack and pinion units

## Design torque

Design torque represents the maximum torque that an actuator must supply in an application. This maximum is the greater of the Demand Torque or the Cushion Torque. If the demand torque exceeds what the actuator can supply, the actuator will either move too slowly or stall. If the cushion torque is too high, the actuator may be damaged by excessive pressure. Demand torque and cushion torque are defined below in terms of load, friction, and acceleration torque.

Equations for calculating demand torque and cushion torque for some general applications are provided on the following pages.

## T - Torque

The amount of turning effort exerted by a rotary actuator.

### T<sub>D</sub> - Demand Torque

This is the torque required from the actuator to do the job and is the sum of the load torque, friction torque, and acceleration torque, multiplied by an appropriate design factor. Design factors vary with the applications and the designers' knowledge.

$$\text{Equation 3) } T_D = T_\alpha + T_f + T_L$$

### T<sub>L</sub> - Load torque

This is the torque required to equal the weight or force of the load. For example, in Fig. 8a, the load torque is 563 N•m (5000 lb-in.); in Fig. 8b the load torque is zero; in Fig. 8c the load torque is 563 N•m (5000 lb-in.). The load torque term is intended to encompass all torque components that aren't included in the friction or acceleration terms.

### T<sub>f</sub> - Friction torque

This is the torque required to overcome friction between any moving parts, especially bearing surfaces. In Fig. 8a, the friction torque is zero for the hanging load; in Fig. 8b the friction torque is 775 N•m (6880 lb-in) for the sliding load; in Fig. 8c the friction torque is zero for the clamp.

$$\text{Equation 4) } T_f = \mu Wr$$

## T<sub>α</sub> - Acceleration Torque

This is the torque required to overcome the inertia of the load in order to provide a required acceleration or deceleration. In Fig. 8a the load is suspended motionless so there is no acceleration. In Fig. 8b, the load is accelerated from 0 to some specified angular velocity. If the mass moment of inertia about the axis of rotation is I and the angular acceleration is α, the acceleration torque is equal to Iα. In Fig. 8c there is no acceleration.

Some values for mass moment of inertia are given in Table 3. Some useful equations for determining α are listed in Table 5. Equation 5 below shows the general equation for acceleration torque.

$$\text{Equation 5) } T_\alpha = I\alpha$$

## T<sub>C</sub> - Cushion Torque

This is the torque that the actuator must apply to provide a required deceleration. This torque is generated by restricting the flow out of the actuator (meter-out) so as to create a back pressure which decelerates the load. This back pressure (deceleration) often must overcome both the inertia of the load and the driving pressure (system pressure) from the pump. See applications.

$$\text{Equation 6) } T_C = T_{\alpha*} + \frac{P_f V}{\theta} - T_f \pm T_L$$

The friction torque T<sub>f</sub> reduces the torque the actuator must apply to stop the load. The load torque T<sub>L</sub> may add to, or subtract from the torque required from the actuator, depending upon the orientation of the load torque. For example, a weight being swung upward would result in a load torque that is subtracted.

**Warning: Rapid deceleration can cause high pressure intensification at the outlet of the actuator. Always insure that cushion pressure does not exceed the manufacturer's pressure rating for the actuator.**



**Demand Torque Examples**

**A) Due to load torque**

The load is held motionless as shown.

$$T_D = T_\alpha + T_f + T_L$$

$$T_\alpha = 0$$

$$T_f = 0$$

$$T_L = (500 \text{ lb})(10 \text{ in}) = 5,000 \text{ lb-in}$$

$$T_D = 5,000 \text{ lb-in}$$

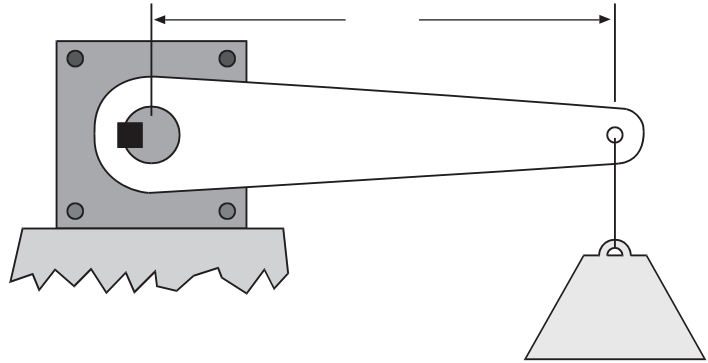

Figure 8a

**B) Due to friction and acceleration**

The 500 lb rotating index table is supported by bearings with a coefficient of friction of .25. The table's acceleration  $\alpha$  is 2 rad/sec<sup>2</sup>. The table's mass moment of inertia I is 2,330 lb-in-sec<sup>2</sup>.

$$T_D = T_\alpha + T_f + T_L$$

$$T_\alpha = I\alpha = (2,330 \text{ lb-in-sec}^2)(2/\text{sec}^2) = 4,660 \text{ lb-in}$$

$$T_f = \mu W r_b = 0.25 (500 \text{ lb})(55 \text{ in}) = 6,880 \text{ lb-in}$$

$$T_L = 0$$

$$T_D = 4,660 \text{ lb-in} + 6,880 \text{ lb-in} = 11,540 \text{ lb-in}$$

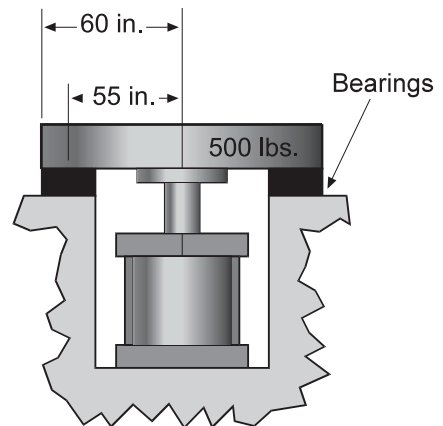

Figure 8b

**C) Due to load torque**

$$T_D = T_\alpha + T_f + T_L$$

$$T_\alpha = 0$$

$$T_f = 0$$

$$T_L = (500 \text{ lb})(10 \text{ in}) = 5,000 \text{ lb-in}$$

$$T_D = 5,000 \text{ lb-in}$$

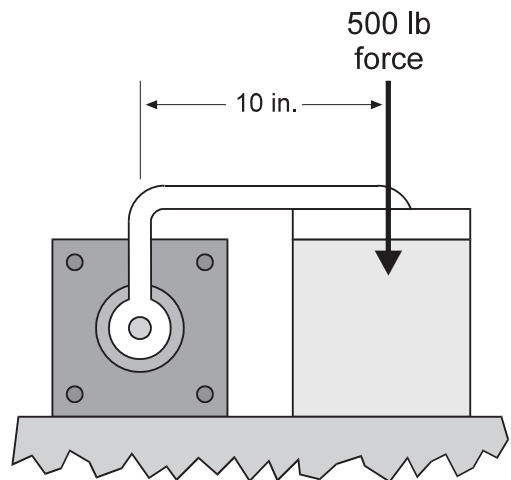
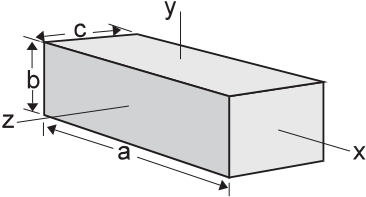
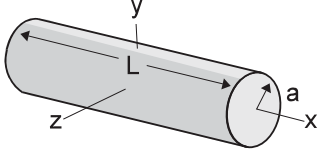
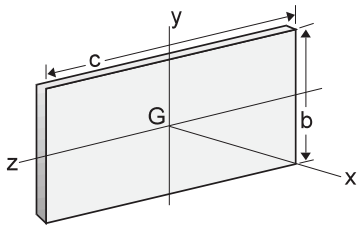
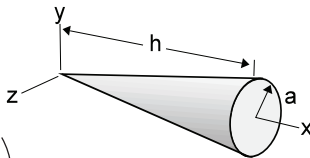
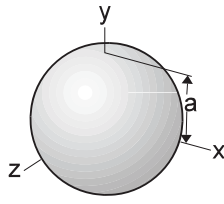
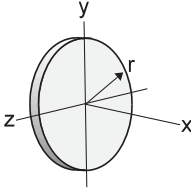
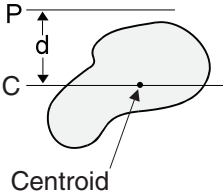

Figure 8c

**Calculating Torque Requirements**

**Table 3: Mass Moments of Inertia**

<p>Rectangular prism</p> $I_x = \frac{1}{12} m(b^2 + c^2)$ $I_y = \frac{1}{12} m(c^2 + a^2)$ $I_z = \frac{1}{12} m(a^2 + b^2)$ 	<p>Circular cylinder</p>  $I_x = \frac{1}{2} ma^2$ $I_y = I_z = \frac{1}{12} m(3a^2 + L^2)$
<p>Thin rectangular plate</p> $I_x = \frac{1}{12} m(b^2 + c^2)$ $I_y = \frac{1}{12} mc^2$ $I_z = \frac{1}{12} mb^2$ 	<p>Circular cone</p>  $I_x = \frac{3}{10} ma^2$ $I_y = I_z = \frac{3}{5} m\left(\frac{1}{4} a^2 + h^2\right)$
<p>Sphere</p> $I_x = I_y = I_z = \frac{2}{5} ma^2$ 	<p>Thin disk</p>  $I_x = \frac{1}{2} mr^2$ $I_y = I_z = \frac{1}{4} mr^2$
<p>Parallel Axis Theorem:</p> $I_p = \bar{I} + md^2$  <p>Centroid</p>	<p><math>I_p</math> = Mass moment of inertia about an axis parallel to a centroidal axis.  <math>\bar{I}_C</math> = Mass moment of inertia about a centroidal axis.              m = Mass              d = distance between axes</p>
<p>When acceleration is constant:</p> $\theta = \omega_0 t + \frac{1}{2} \alpha t^2$ $\alpha = \frac{2\theta}{t^2}$ $\theta = \omega_0 t + \frac{1}{2} \omega_t t$ $\alpha = \frac{(\omega_t - \omega_0)^2}{2\theta}$ $\omega = \omega_0 + \alpha t$ $\alpha = \frac{(\omega_t - \omega_0)}{t}$	<p>When velocity is constant:</p> $\theta = \omega t$ <p>t = time  <math>\theta</math> = angular distance  <math>\omega_t</math> = angular velocity at time = t  <math>\omega_0</math> = angular velocity at time = 0  <math>\alpha</math> = angular acceleration</p>

Round Index Table ..... 12  
Rotary Index Table with Rectangular Load ..... 12  
Rotary Index Table with Cylindrical Load ..... 13  
Wire or Round Tube Bending ..... 13  
Screw Clamping ..... 14  
Simple Clamp ..... 14  
Linear Motion, Clamping ..... 15  
Modified Linear Motion, Clamping ..... 15  
Overcenter Load ..... 16  
Harmonic Drive ..... 16-18

**NOTES:**

1. The following equations are intended only as a guide. The design engineer should verify the accuracy of the equations and insure that all performance, safety and warning requirements of the application are met.
2. Unless specified otherwise, the following examples do not take into account actuator efficiency, system efficiency, friction or needed safety factors.
3. Deceleration torques are based upon the assumption that restrictor type flow controls force the pump to exert maximum pressure during deceleration. This is denoted as  $P_r$ .
4. Symbol followed by \* indicates a deceleration.

**Round Index Table**

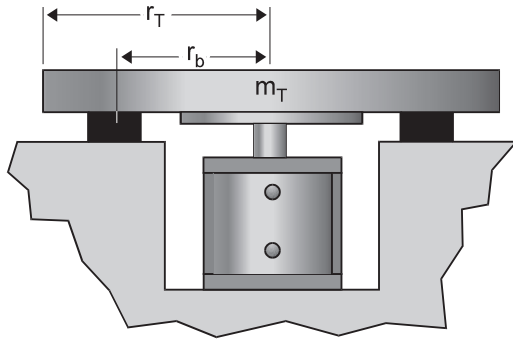

$$T_D = \frac{1}{2} m_T r_T^2 \alpha + \mu W_1 r_b$$

$$T_C = \frac{1}{2} m_T r_T^2 \alpha + I_1 \alpha$$

A round index table that must overcome bearing friction and inertia. Assumptions, see notes 1, 2, and 3.

$$T_D = T_\alpha + T_f + T_L$$

$$T_L = 0, \text{ no load}$$

$$T_f = \mu W_1 r_b, \text{ where } W_1 = m_1 g_C$$

$$T_\alpha = I_1 \alpha$$

$$I_1 = \frac{1}{2} m_1 r_1^2$$

$$T_C = \frac{P_r V}{\theta} + T_{\alpha^*} - T_f \pm T_L$$

$$P_C = T_C \left[ \frac{\theta}{V} \right]$$

**Rotary Index Table with Rectangular Load**

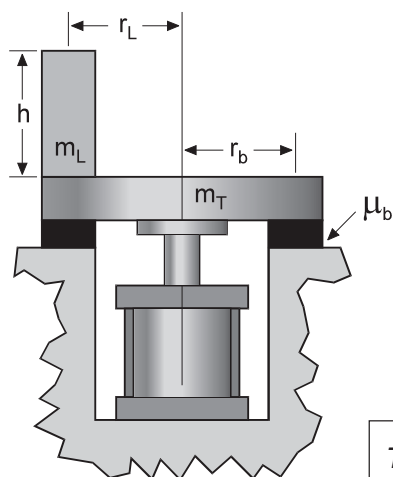
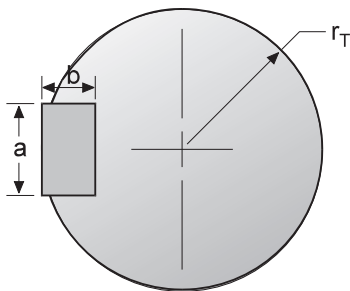

An index table rotating in a horizontal plane with a rectangular box. It must overcome bearing friction and inertia. Assumptions, see notes 1, 2, and 3.

$$T_D = T_\alpha + T_f + T_L$$

$$T_L = 0, \text{ no load}$$

$$T_f = (W_T + W_L) r_b \mu_b$$

where  $W_T = m_T g_C$ ,  $W_L = m_L g_C$

$$T_\alpha = (I_T + I_L) \alpha$$

$$I_T = \frac{1}{2} m_T r_T^2$$

$$I_L = \frac{1}{12} m_L (a^2 + b^2) + m_L r_L^2$$

$$T_C = \frac{P_r V}{\theta} + T_{\alpha^*} - T_f \pm T_L$$

$$T_{\alpha^*} = (I_T + I_L) \alpha^*$$

$$P_C = T_C \left[ \frac{\theta}{V} \right]$$

$$T_D = (W_T + W_L) r_b \mu_b + \alpha \left[ \frac{1}{2} m_T r_T^2 + \frac{1}{12} m_L (a^2 + b^2) + m_L r_L^2 \right]$$

$$T_C = (\alpha + \alpha^*) \left[ \frac{1}{2} m_T r_T^2 + \frac{1}{12} m_L (a^2 + b^2) + m_L r_L^2 \right]$$

**Rotary Index Table with Cylindrical Load**

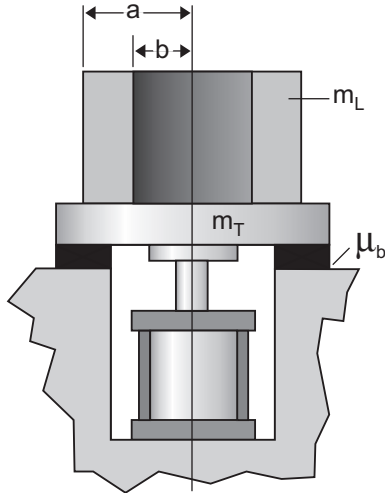

An index table rotating in a horizontal plane with a cylindrical load. It must overcome bearing friction and inertia. Assumptions, see notes 1, 2, and 3 on page 4-12.

$$T_D = T_\alpha + T_f + T_L$$

$$T_L = 0, \text{ no load}$$

$$T_f = (W_T + W_L)r_b\mu_b,$$

$$T_\alpha = (I_T + I_L)\alpha$$

$$I_T = \frac{1}{2}m_T r_T^2$$

$$I_L = \frac{1}{2}m_L(a^2 - b^2)$$

$$T_C = \frac{P_r V}{\theta} + T_{\alpha^*} - T_f \pm T_L \quad P_C = T_C \left[ \frac{\theta}{V} \right]$$

$$T_{\alpha^*} = (I_T + I_L)\alpha^*$$

$$T_D = (W_T + W_L)r_b\mu_b + \frac{\alpha}{2} [m_T r_T^2 + m_L(a^2 - b^2)]$$

$$T_C = \frac{1}{2} (\alpha + \alpha^*) [m_T r_T^2 + m_L(a^2 - b^2)]$$

**Wire or Round Tube Bending**

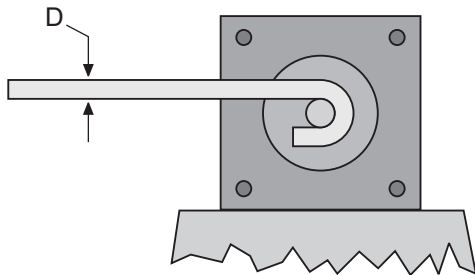

Bending tube or wire, no acceleration or friction concerns.

No acceleration,  $T_\alpha = 0$   
No friction,  $T_f = 0$

$$T_D = T_L$$

$$T_L = \sigma_y \frac{I}{C}$$

$\sigma_y$  = yield stress of the material (available from mechanical engineering texts)

$\frac{I}{C}$  = section modulus of the tube or wire (can be calculated or found in materials handbooks)

D = Outer diameter of wire or tube

d = Inside diameter of tube

Round tubing:  $T_D = \frac{\pi}{32} \left( \frac{D^4 - d^4}{D} \right) \sigma_y$

Round wire:  $T_D = \frac{\pi \sigma_y D^3}{32}$

**Screw Clamping**

Screw clamp with no acceleration, neglecting friction.

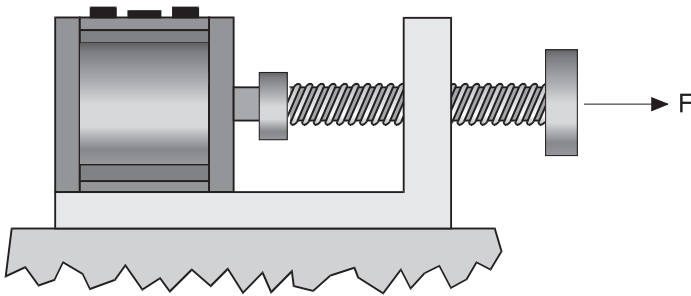

$$T_D = T_\alpha + T_f + T_L$$

$$T_\alpha = 0$$

$$T_f = 0 \text{ *see note below}$$

$$T_L = \frac{Fp}{2\pi}$$

p = threads per inch

F = clamping force

\*Friction torque could vary significantly based upon screw type, lubrication type, and bearings. To better approximate screw friction torque consult a machine design handbook.

**Simple Clamp**

A simple clamping mechanism with no friction or acceleration.

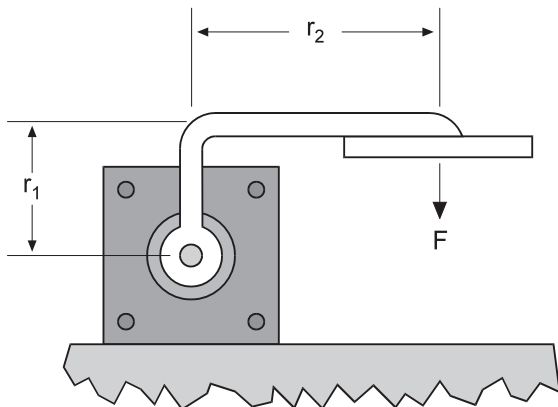

$$T_D = T_\alpha + T_f + T_L$$

$$T_\alpha = 0$$

$$T_f = 0$$

$$T_L = Fr_2$$

This clamping mechanism may be suitable for holding down parts for assembly, but does not have the mechanical advantage or the linear motion provided in the next two examples.

**Linear Motion, Clamping**

This type of clamp is characterized by a long stroke and a high clamping force as  $\theta$  approaches zero.\*

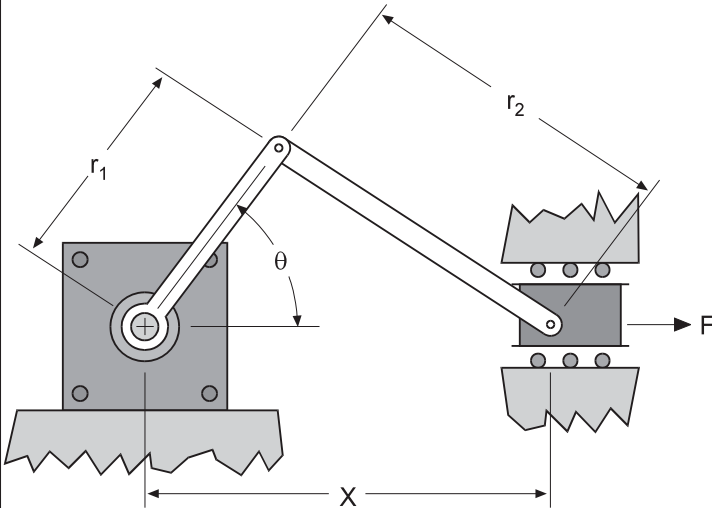

$$T_D = T_\alpha + T_f + T_L$$

$$T_\alpha = 0$$

$$T_f = 0$$

$$T_L = \frac{Fr_1}{2} \left[ \frac{\sin 2\theta}{x - r_1 \sin \theta} + 2 \sin \theta \right]$$

$$x = r_1 \cos \theta + \sqrt{r_2^2 - r_1^2 \sin^2 \theta}$$

\*To maintain control,  $\theta$  should never be allowed to equal zero. Also, the force F should not be allowed to exceed the actuator's bearing capacity.

**Improved Linear Motion, Clamping**

Same as above, except that force is not limited by the actuator's bearing capacity.

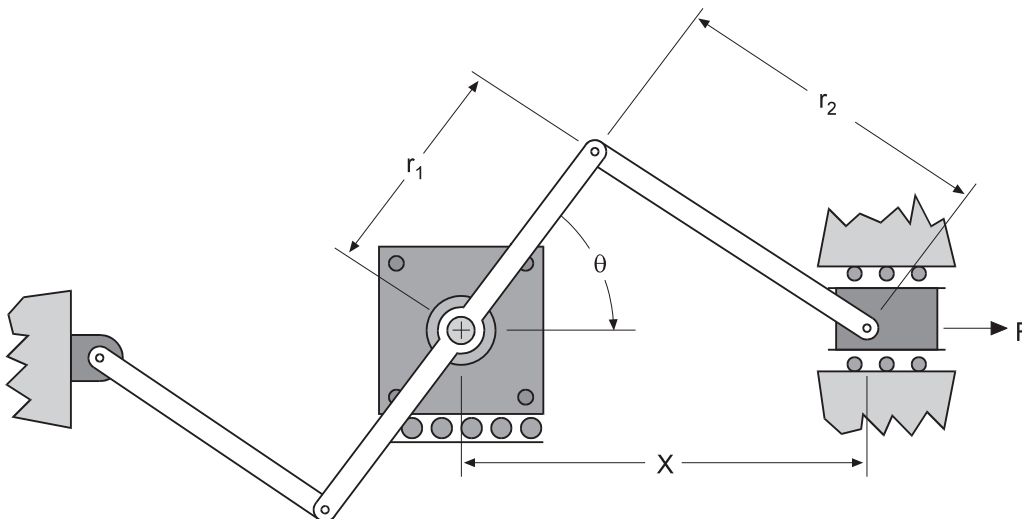

\*To maintain control,  $\theta$  should never be allowed to equal zero.

**Overcenter Load**

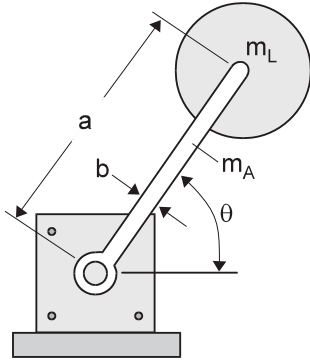

If the mass  $m_L$  is not free to rotate about its center, then its mass moment of inertia about its own center  $I_L$  must be included in the equations for  $T_a$  and  $T_{a^*}$  as follows:

$$T_\alpha = \left[ \frac{1}{12} m_A(a^2 + b^2) + I_L + m_L a^2 \right] \alpha$$

$$T_{\alpha^*} = \left[ \frac{1}{12} m_A(a^2 + b^2) + I_L + m_L a^2 \right] \alpha^*$$

The load is rotated in a vertical plane. Load torque  $T_L$  is positive or negative depending upon position and direction of rotation. If the load resists the actuator's rotation, then  $T_L$  is positive. The mass  $m_L$  is free to rotate about its center.

$$T_D = T_\alpha + T_f + T_L$$

$$T_\alpha = I\alpha = \left[ \frac{1}{12} m_A(a^2 + b^2) + m_L a^2 \right] \alpha$$

$$T_f = r_b \mu_b (W_L + W_A)$$

$r_b$  = shaft bearing radius, not shown

$\mu_b$  = bearing coefficient of friction

In most cases  $T_f$  will be very small compared to  $T_L$ .

$$T_L = \pm a \cos \theta \left[ \frac{1}{2} W_A + W_L \right]$$

$$T_{D,MAX} = a \left[ \frac{1}{2} W_A + W_L \right] + T_f + T_\alpha$$

$$T_C = \frac{P_f V}{\theta} + T_{\alpha^*} - T_f \pm T_L$$

$$T_{C,MAX} = \frac{P_f V}{\theta} + T_{\alpha^*} - T_f + a \cos \theta \left( \frac{1}{2} W_A + W_L \right)$$

$$T_{\alpha^*} = I\alpha^* = \left[ \frac{1}{12} m_A(a^2 + b^2) + m_L a^2 \right] \alpha^*$$

$$P_C = T_C \left[ \frac{\theta}{V} \right]$$

**Harmonic Drive**

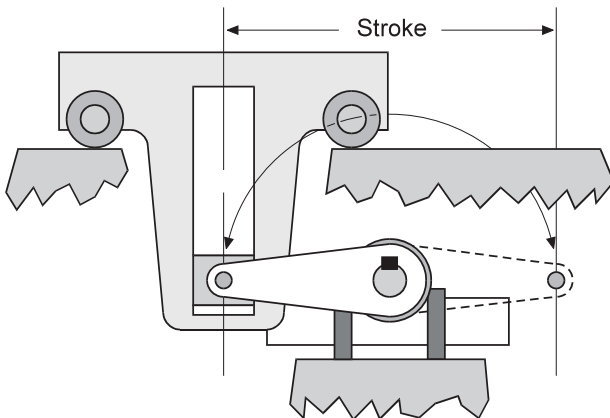

A harmonic linkage, as shown, is a compact and low cost method of providing linear motion with a very smooth acceleration.

Flow controls can be adjusted to provide the smooth acceleration and deceleration necessary to handle fragile parts such as bottles or light bulbs.

The smooth acceleration and deceleration also enables optimum cycle times for handling automotive components on transfer lines.

A schematic model of the harmonic drive is shown on the following page. The equations for demand torque,  $T_D$  will be defined in terms of the schematic model.

**continued . . .**



**Harmonic Drive, continued**

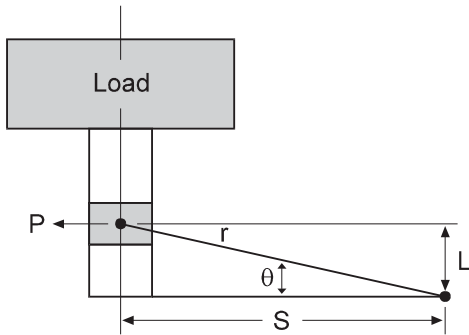

- $T_D$  = Actuator demand torque
- $r$  = Torque arm length
- $L = r \sin \theta$
- $S = \text{Stroke} = r \cos \theta$
- $W$  = Weight of the load
- $P$  = Bearing force against the slide
- $g$  = Gravitational acceleration
- $\mu_L$  = Friction coefficient of the load
- $\mu_S$  = Friction coefficient of the slide
- $\theta$  = Actuator rotation in radians
- $\omega$  = Angular velocity in rad/sec
- $t$  = time in seconds

A general equation can be derived relating the torque needed  $T_D$  to the object weight  $W$ , radius  $r$ , friction coefficients  $\mu_S$  and  $\mu_L$ , and the angular position  $\theta$ . Because the position is expected to change with time  $t$ , the product of time and angular velocity  $\omega$  is substituted for  $\theta$  in the equations below.

$$A.) \quad \frac{T_D}{W} = \frac{r^2 \omega^2}{g} \cos \omega t \sin \omega t + \frac{r^2 \omega^2 \mu_S}{g} \cos^2 \omega t + r \mu_L \sin \omega t + r \mu_L \mu_S \cos \omega t$$

Equation A gives the ratio of torque per weight for any time throughout the motion of the harmonic drive. To select an actuator it is the worst case torque that must be used for calculating  $T_D$ . The worst case, or maximum demand torque, can be calculated by taking the derivative of equation A with respect to time and solving for when the derivative is equal to zero. For reference the derivative of equation A with respect to time is given as equation B below.

$$B.) \quad \frac{d(T_D/W)}{dt} = \frac{r \omega^2}{g} (2 \cos^2 \omega t - 1) - \frac{2 r \omega^2 \mu_S}{g} \cos \omega t \sin \omega t + \mu_L \cos \omega t - \mu_L \mu_S \sin \omega t$$

Equations A and B have been solved to create the graphs on the next page for coefficients of friction of 0.05 and 0.25 respectively. (For the graphs, the coefficients  $\mu_S$  and  $\mu_L$  are set equal to each other.)

The preceding equations assume a constant angular velocity  $\omega$ ; as the inertia from the moving load tends to drive the actuator during the deceleration phase, it is recommended that pressure compensated restrictor type flow controls be used.

$$C.) \quad T_C = \frac{P_r V}{\theta} + T_D - W \left[ \frac{T_D}{W} \text{ (evaluated at 10 second throw time on graph)} \right]$$

Where  $P_r$  is the relief valve pressure,  $V$  is the actuator displacement, and  $\theta$  is the actuators rated rotation in radians.

Harmonic Drive, continued

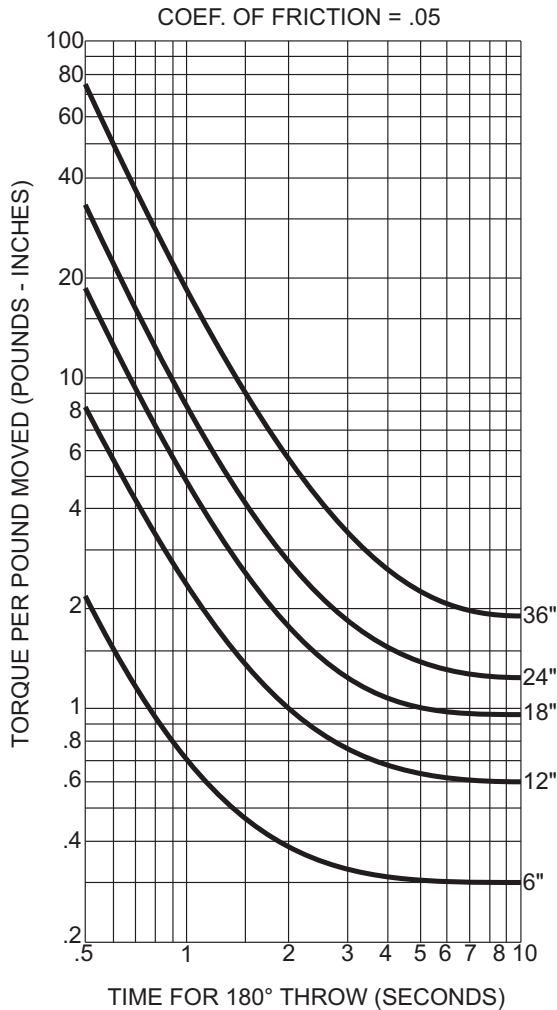

Figure 9

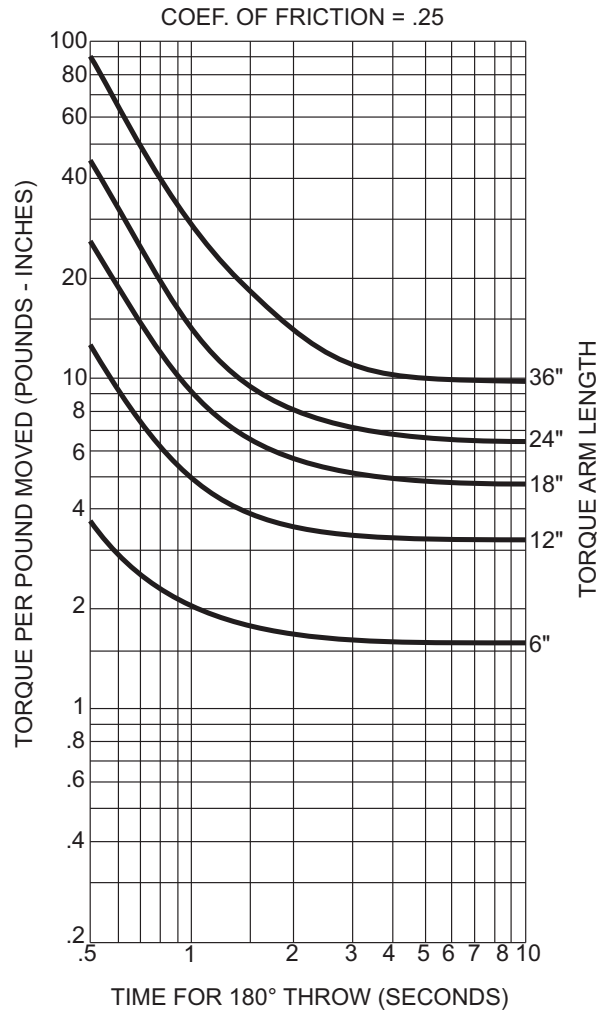

Figure 10

**Example 1E:** A 400 lb block must be moved 48 inches in 4 seconds with a harmonic drive. The block and the slide are supported with roller bearings (coeff. of friction = 0.05). a.) Calculate the demand torque  $T_D$  required. b.) Calculate the cushion torque if a 180° rotary actuator with a displacement  $V$  of 7.6 in<sup>3</sup> is chosen, and the relief valve pressure  $P_r$  is set at 500 psi.

**Solution:**

a.) Use the curves for coeff. of friction = 0.05 and draw a line from the 4 seconds on the time axis to intersect with the 24 inch torque arm curve.

$$\frac{48 \text{ in travel}}{2} = 24 \text{ in torque arm length}$$

The intersecting line shows a requirement for  $T_D/W = 1.5$ :  $T_D = 1.5 (400 \text{ lb}) = 600 \text{ lb-in}$  answer

b.) Use equation C from the previous page to calculate the cushion torque  $T_C$ :

$$T_C = \frac{500 \text{ psi} (7.6 \text{ in}^3)}{\pi} + 600 \text{ lb-in} - \left(\frac{1.2 \text{ lb-in}}{\text{lb}}\right) (400 \text{ lb}) = 1,329 \text{ lb-in}$$
 answer

## Sizing Rotary Actuators

The smallest rotary actuator displacement, that can be used in an application, is that displacement which can both deliver sufficient torque to move the load and also withstand the pressure required to stop the load. (Recall that cushion torque is generated by back pressure that is often greater than system pressure.) A method of determining the smallest rotary actuator displacement is summarized in Fig. 11 and outlined step-by-step below. (Also see the example problem on page 23.)

**Note:** This method is for constant torque rotary actuators such as vane, rack and pinion, or helical styles.

- A. Determine the maximum allowable safe system pressure  $P_r$  that the pump and components can tolerate. This is typically the highest pressure the pump can supply to the system; however, this is not the actual system working pressure. The actual working pressure is determined after an actuator is selected.
- B. Calculate the demand torque required. The demand torque  $T_D$  is given by equation 3 repeated here:

$$T_D = T_\alpha + T_f + T_L$$

Definitions for the above torque components and examples for calculation of  $T_D$  were discussed previously under the heading "Calculating Torque Requirements."

- C. Calculate  $V/\theta$  based upon  $T_D$  and the maximum system pressure chosen in Step A.  $V/\theta$  is the volume displacement per one radian of rotation for a rotary actuator.  $V/\theta$  can be calculated from the Equation 7, or by using Fig. 14. (Fig. 12 for S.I. units).

$$\text{Equation 7) } \frac{V}{\theta} = \frac{T_D}{P_r}$$

- D. Calculate the cushion torque  $T_C$  required. In any application where the actuator has cushions, a deceleration valve, or any form of meter-out flow control, the flow out of the actuator is restricted creating a back pressure on the outlet side of the actuator. This back pressure is what creates the cushion torque which acts to decelerate, or cushion the actuator as it approaches the end of its rotation. The cushion torque can be calculated by the methods presented under the heading "Calculating Torque Requirements."

- E. Calculate the cushion pressure  $P_C$  for the rotary actuator with  $V/\theta$  as calculated in step C, and  $T_C$  as calculated in step D. Use Equation 8:

$$\text{Equation 8) } P_C = T_C \left[ \frac{\theta}{V} \right]$$

**Note: Equation 8 calculates the average back pressure  $P_C$ , not the maximum back pressure. In most cases back pressure will not be constant and will exceed the average value calculated here.**

- F. If the value for  $P_C$  is considered impractical for your application, some ways to lower it are:
  1. Reduce system pressure, then recalculate Steps C through E.
  2. Increase the time for deceleration, then recalculate Steps D and E.
  3. Use an external shock absorber.
- G. Calculate the needed displacement  $V$  for the rotation you need. Use Equation 9 or Fig. 15. (Fig. 13 for S.I. units.)

$$\text{Equation 9) } V = \theta \left[ \frac{V}{\theta} \right]$$

- H. Select a rotary actuator with a torque rating greater than  $T_D$ , a displacement greater than  $V$ , and a pressure rating greater than  $P_C$ . Calculate system operating pressure  $P$  based upon the selected actuator's rated torque  $T$ , and the selected actuator's  $V/\theta$  value using Equation 10 or Fig. 12.

$$\text{Equation 10) } P = T \left[ \frac{V}{\theta} \right]$$

The relief valve setting  $P_r$  must be less than the maximum pressure from Step A, must be greater than  $P$  calculated in Equation 10, must not exceed the actuator's rated working pressure, and must be high enough to compensate for pressure drop through valves and lines.

**Actuator Flow Chart**

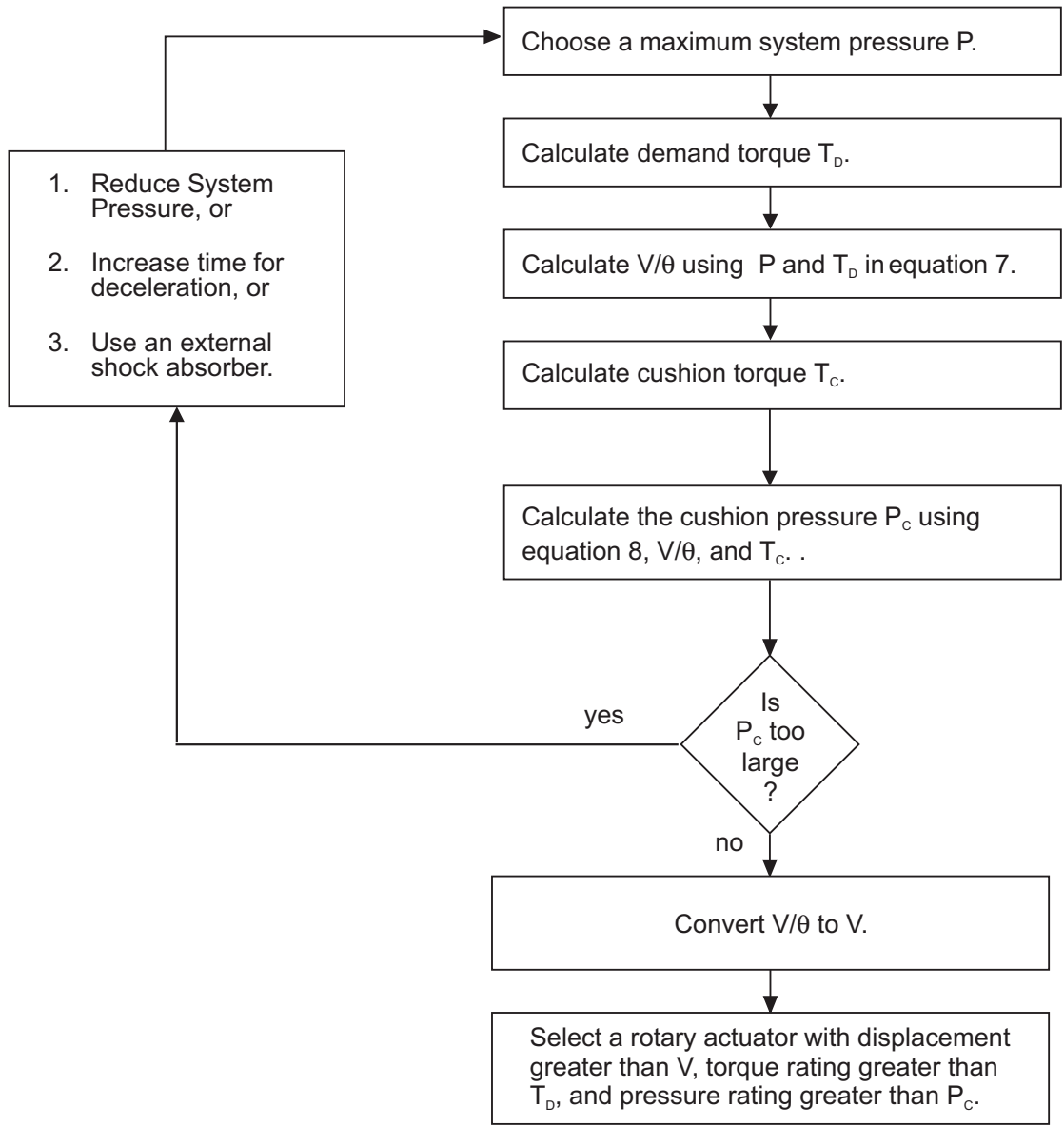
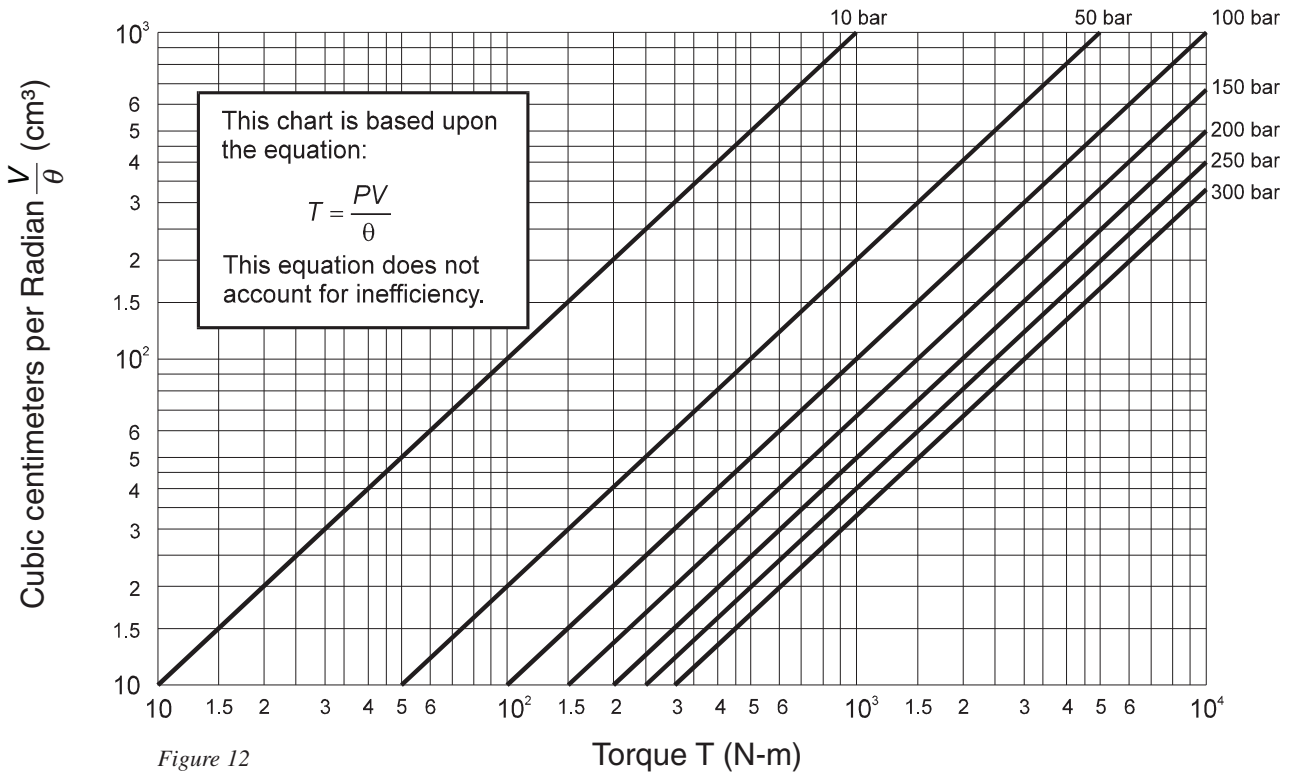
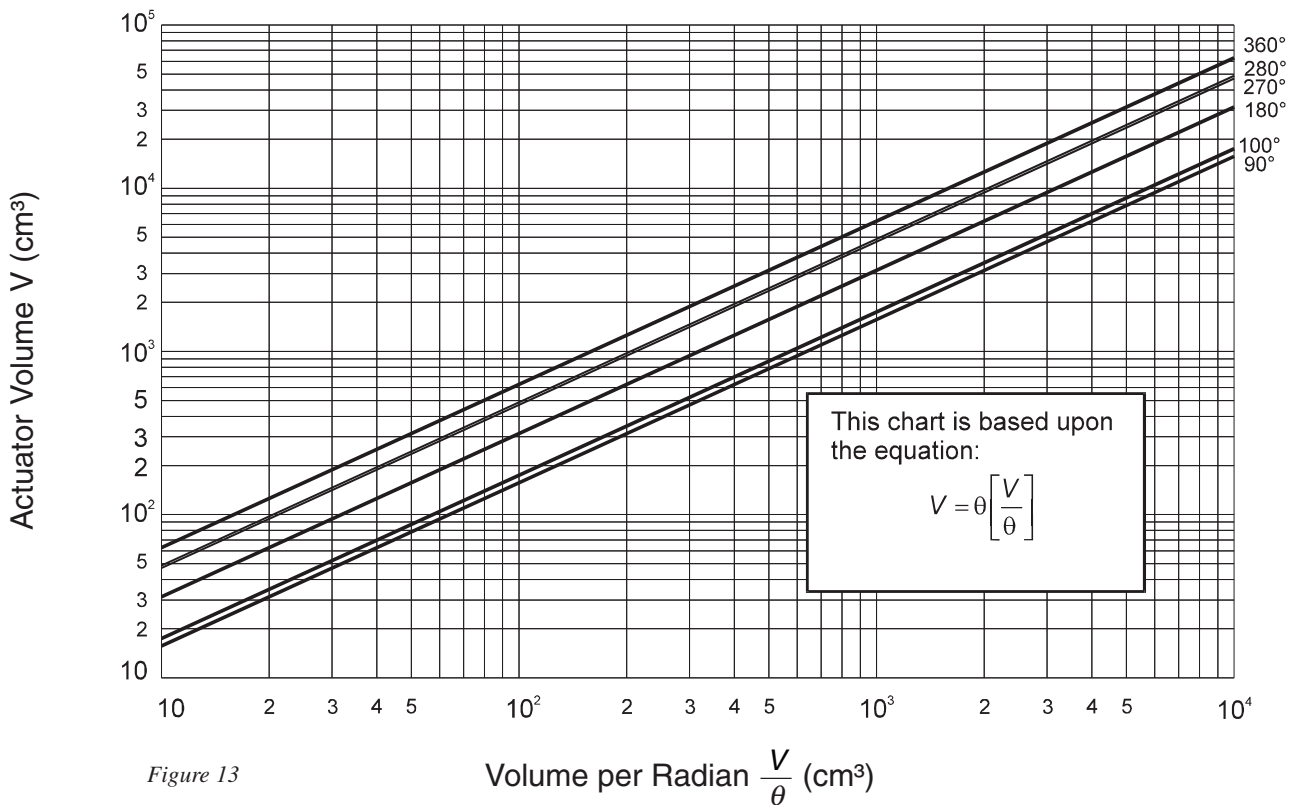

Figure 11: Flow chart for selecting a minimum volume actuator. See example problem page 23.

**Minimum Possible Rotary Actuator Volume (S.I. Units)**



**Converting Volume per Radian to Volume Displacement (S.I. Units)**



**Minimum Possible Rotary Actuator Volume (English Units)**

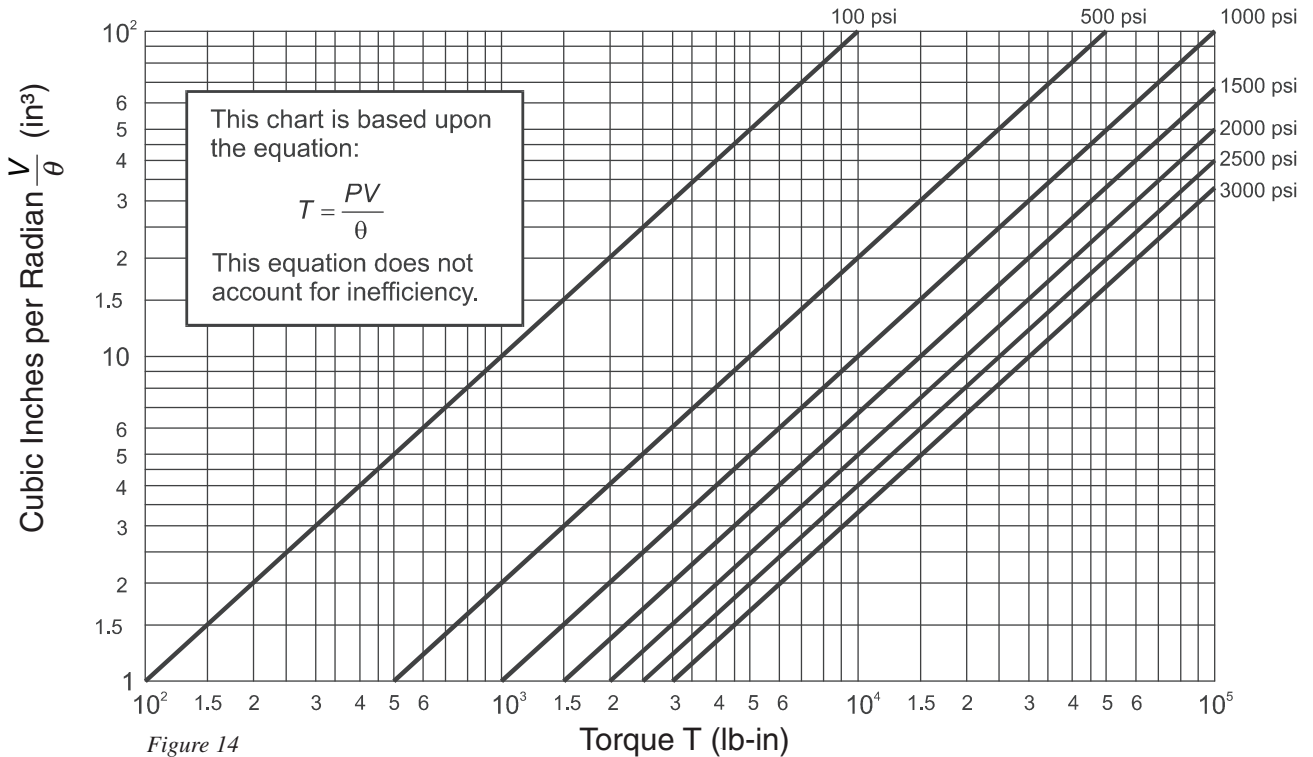

**Converting Volume per Radian to Volume Displacement (English Units)**

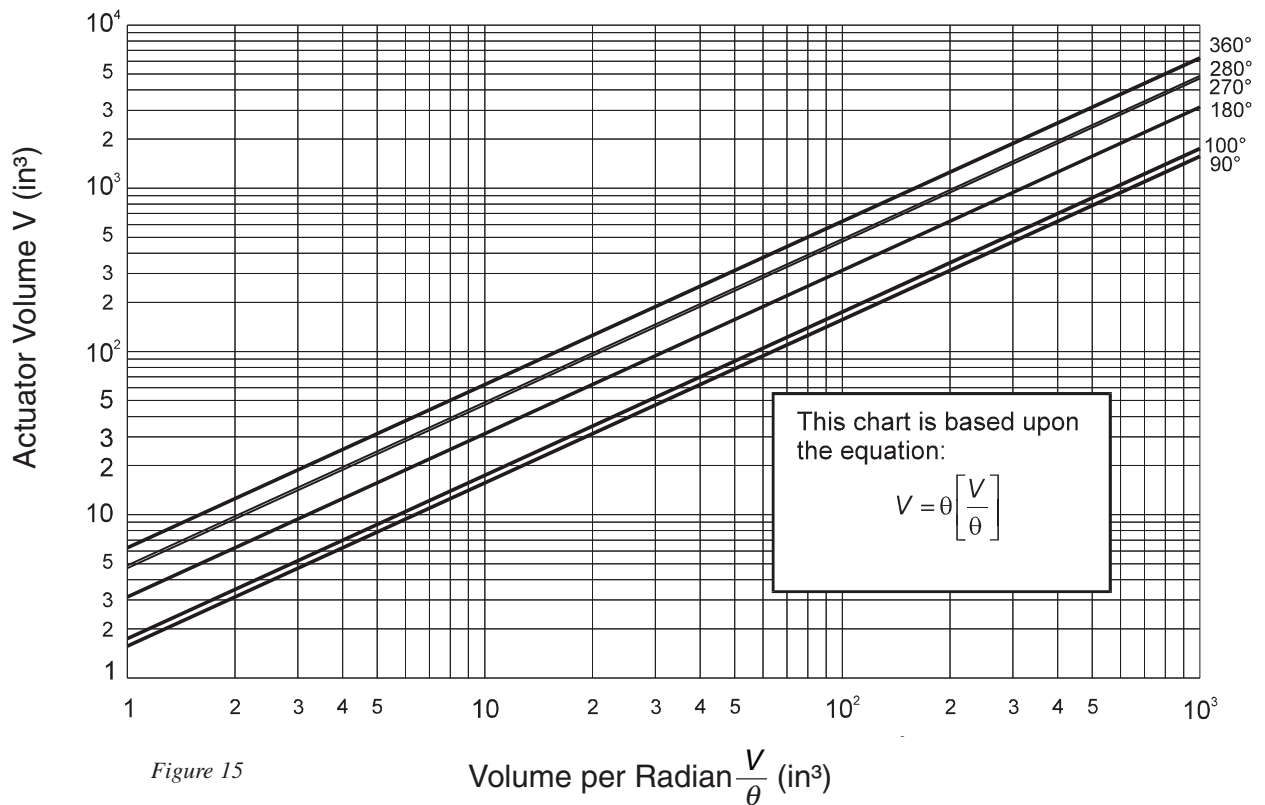

**Example 2E:** For the rotary index table shown, calculate the minimum requirements for an actuator to turn the index table 180°. Use  $\alpha = \alpha^* = 2.5 \text{ rad/sec}^2$ ,  $P_r = 1000 \text{ psi}$ .

**Solution:** Use the flow chart Fig. 11, on page 20.

A.) The supply pressure  $P_r$  is given as 1000 psi.

B.) Calculate the demand torque  $T_D$ :

$$T_D = T_\alpha + T_f + T_L$$

$$T_\alpha = I\alpha$$

$$I = \frac{1}{2}mr^2 = \frac{1}{2}\left(\frac{500 \text{ lb}}{386 \text{ in/sec}^2}\right)(60 \text{ in})^2 = 2332 \text{ lb-in-sec}^2$$

$$\alpha = 2.5 \text{ rad/sec}^2$$

$$T_\alpha = (2332 \text{ lb-in-sec}^2)(2.5 \text{ rad/sec}^2) = 5,830 \text{ lb-in}$$

$$T_f = \mu W r_b = (0.10)(500 \text{ lb})(40 \text{ in}) = 2,000 \text{ lb-in}$$

$$T_L = 0$$

$$T_D = 5,830 \text{ lb-in} + 2,000 \text{ lb-in} + 0 = 7,830 \text{ lb-in}$$

C.) Calculate  $\frac{V}{\theta}$  use Equation 7 or Fig. 14:

$$\frac{V}{\theta} = \frac{T_D}{P_r} = \frac{7,830 \text{ lb-in}}{1000 \text{ psi}} = 7.83 \text{ in}^3$$

D.) Calculate cushion torque  $T_C$  (see equations for Rotary Index Table)

$$T_C = \frac{P_r V}{\theta} + T_{\alpha^*} - T_f + T_L = 1000 \text{ psi} (7.83 \text{ in}^3) + 5,830 \text{ lb-in} - 2000 \text{ lb-in} + 0 = 11,660 \text{ lb-in}$$

Notice that since the rate of deceleration  $\alpha^*$  is the same as the rate of acceleration  $\alpha$ , the deceleration torque  $T_{\alpha^*}$  is the same as the acceleration torque  $T_\alpha$ .

E.) Calculate the cushion pressure  $P_C$ :

$$P_C = T_C \left[ \frac{\theta}{V} \right] = \frac{11,660 \text{ lb-in}}{7.83 \text{ in}^3} = 1,489 \text{ psi}$$

F.) Is the cushion pressure too high? The cushion pressure (1,489 psi) is within the capability of most hydraulic rotary actuators. In cases where  $P_C$  becomes the dominant selection criteria, the designer should consider repeating the sizing calculations with a lower value for  $P_r$ , decreasing the deceleration rate  $\alpha^*$ , or using an external shock absorber.

G.) Calculate the displacement  $V$  for the 180° rotation. Use Equation 9 or Fig. 15.

$$V = \theta \left[ \frac{V}{\theta} \right] = \pi(7.83 \text{ in}^3) = 24.6 \text{ in}^3$$

H.) Select a rotary actuator with a torque rating greater than 7,830 lb-in with a supply pressure of 1000 psi, it will have a displacement greater than 24.6 in<sup>3</sup>, and must have a maximum pressure rating over 1,489 psi.

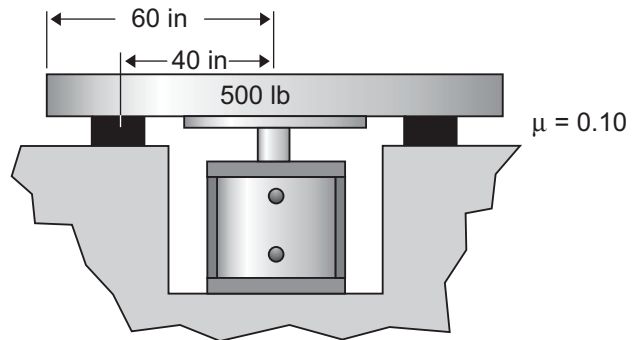

**TABLE 4: CONVERT  $V_s$  to V**

Based upon equation  $V_s\theta = V$  for converting specific volume into volume.

**ACTUATOR ROTATION VOLUME**

<b><math>V_s</math></b>	<b>ACTUATOR ROTATION (DEGREES)</b>					
	<b>90</b>	<b>100</b>	<b>180</b>	<b>270</b>	<b>280</b>	<b>360</b>
10	15.71	17.45	31.42	47.13	48.86	62.84
11	17.28	19.20	34.56	51.84	53.75	69.12
12	18.85	20.94	37.70	56.56 5	8.63	75.41
13	20.42	22.69	40.84	61.27	63.52	81.69
14	21.99	24.43	43.98	65.98	68.40	87.98
15	23.57	26.18	47.13	70.70	73.29	94.26
16	25.14	27.92	50.27	75.41	78.18	100.5
17	26.71	29.67	53.41	80.12	83.06	106.8
18	28.28	31.41	56.55	84.83	87.95	113.1
19	29.85	33.16	59.70	89.55	92.83	119.4
20	31.42	34.90	62.84	94.26	97.72	125.7
22	34.56	38.39	69.12	103.7	107.5	138.2
24	37.70	41.88	75.41	113.1	117.3	150.8
26	40.84	45.37	81.69	122.5	127.0	163.4
28	43.99	48.86	87.98	132.0	136.8	176.0
30	47.13	52.35	94.26	141.4	146.6	188.5
32	50.27	55.84	100.5	150.8	156.4	201.1
34	53.41	59.33	106.8	160.2	166.1	213.7
36	56.56	62.82	113.1	169.7	175.9	226.2
38	59.70	66.31	119.4	179.1	185.7	238.8
40	62.84	69.80	125.7	188.5	195.4	251.4
42	65.98	73.29	132.0	197.9	205.2	263.9
44	69.12	76.78	138.2	207.4	215.0	276.5
46	72.27	80.27	144.5	216.8	224.8	289.1
48	75.41	83.76	150.8	226.2	234.5	301.6
50	78.55	87.25	157.1	235.7	244.3	314.2
55	86.41	95.98	172.8	259.2	268.7	345.6
60	94.26	104.7	188.5	282.8	293.2	377.0
65	102.12	113.4	204.2	306.3	317.6	408.5
70	109.97	122.2	219.9	329.9	342.0	439.9
75	117.83	130.9	235.7	353.5	366.5	471.3
80	125.68	139.6	251.4	377.0	390.9	502.7
85	133.54	148.3	267.1	400.6	415.3	534.1
90	141.39	157.1	282.8	424.2	439.7	565.6
95	149.25	165.8	298.5	447.7	464.2	597.0
100	157.1	174.5	314.2	471.3	488.6	628.4



**Calculating Required Pump Flow**

The flow rate required for a rotary actuator can be determined by the desired time for rotation and the rotary actuator's displacement. This is shown in Equation 5.

The equation is also plotted as Figure 16.

$$Q = \frac{V}{t}$$

where Q = Flow rate  
 V = Rotary actuator displacement  
 t = Time to fill displacement

**EXAMPLE:** A 280° vane rotary actuator is chosen to provide a 194° rotation in 2 seconds. If the rotary actuator's displacement is 77.8 in<sup>3</sup>, find what flow rate is required from the pump. Assume constant angular velocity.

**SOLUTION:** The actuator is only rotating 194°, so the volume of oil required for this rotation is:

$$V = 77.8 \text{ in}^3 (194/280)$$

$$V = 53.9 \text{ in}^3 \text{ for } 194^\circ \text{ rotation}$$

$$Q = \frac{V}{t}$$

$$Q = \frac{59.3 \text{ in}^3 (60 \text{ sec/min})}{2 \text{ sec } (231 \text{ in}^3/\text{gal})} = 7 \text{ GPM ANSWER}$$

**EXAMPLE:** A 180° rack and pinion rotary actuator is to accelerate from 0 to some angular velocity  $\omega$  during its first 10° of rotation, then remain at that angular velocity for the next 150° of rotation, then decelerate back to 0 radians/sec during the last 20°. The actuator is to rotate the total 180° in less than 2 seconds. If the actuator's displacement is 36 in<sup>3</sup>, find:

- A. The angular velocity  $\omega$  after the first 10° of rotation
- B. The pump flow rate required for the rotary actuator
- C. The pump flow required if the actuator traveled the entire 180° in 2 seconds at a constant angular velocity

**SOLUTION:**

- A. Assume constant acceleration during the first 10° and constant deceleration during the last 20°.

$$2 \text{ sec} = t_1 + t_2 + t_3$$

$$t_1 = 2 \frac{\theta_1 - 0}{\omega} = \frac{2}{\omega} (10^\circ) \frac{\pi}{180^\circ} = \frac{1}{\omega} (.35)$$

$$t_2 = \frac{\theta_2 - \theta_1}{\omega} = \frac{1}{\omega} (150^\circ) \frac{\pi}{180^\circ} = \frac{1}{\omega} (2.62)$$

$$t_3 = 2 \frac{\theta_3 - \theta_2}{\omega} = \frac{2}{\omega} (20^\circ) \frac{\pi}{180^\circ} = \frac{1}{\omega} (.70)$$

$$2 \text{ sec} = \frac{1}{\omega} [.35 + 2.62 + .70]$$

$$\omega = 1.83 \text{ rad/sec ANSWER}$$

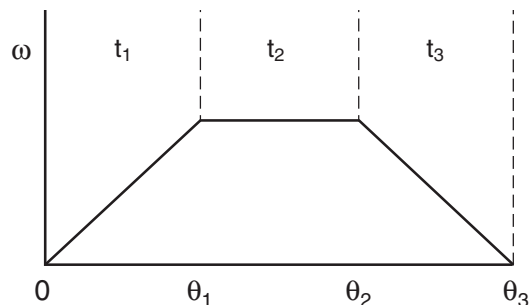

CONTINUED ON NEXT PAGE

**EXAMPLE CONTINUED**

- B. 180° rotary actuator has a volume displacement of 36 in<sup>3</sup>.  
The cubic inches per radian can be expressed as:

$$V_s = \frac{V}{\theta} = \frac{36 \text{ in}^3}{\pi} \text{ radians}$$

$$V_s = 11.5 \text{ in}^3/\text{radian}$$

NOTE: 180° =  $\pi$  radians

The actuator must be able to rotate at 1.83 rad/sec so the pump flow must be:

$$Q = V_s \omega$$

$$Q = (11.5 \text{ in}^3/\text{radian}) (1.83 \text{ rad/sec}) \frac{1 \text{ gal}}{231 \text{ in}^3} \frac{60 \text{ sec}}{\text{min}}$$

$$Q = 5.5 \text{ GPM ANSWER}$$

- C. If the entire 180° were traversed at constant speed in 2 seconds, the pump flow would be:

$$Q = \frac{V}{t}$$

$$Q = \frac{36 \text{ in}^3}{2 \text{ sec}} \frac{1 \text{ gal}}{231 \text{ in}^3} \frac{60 \text{ sec}}{\text{min}}$$

$$Q = 4.7 \text{ GPM ANSWER}$$

Notice that in the above example, it is necessary to take into account the time required for acceleration and deceleration of the actuator in order to determine the maximum velocity required. It is the maximum velocity of the actuator that will determine the maximum flow required. Equations for velocity and acceleration are provided on page 10 in Table 5.

**Time/Revolution vs. Volume**

Based on 100% efficiency and the equation:

$$t = .26 V/Q$$

where  $t$  = time/rev. in seconds

$V$  = displacement in  $\text{in}^3$

$Q$  = oil flow in GPM

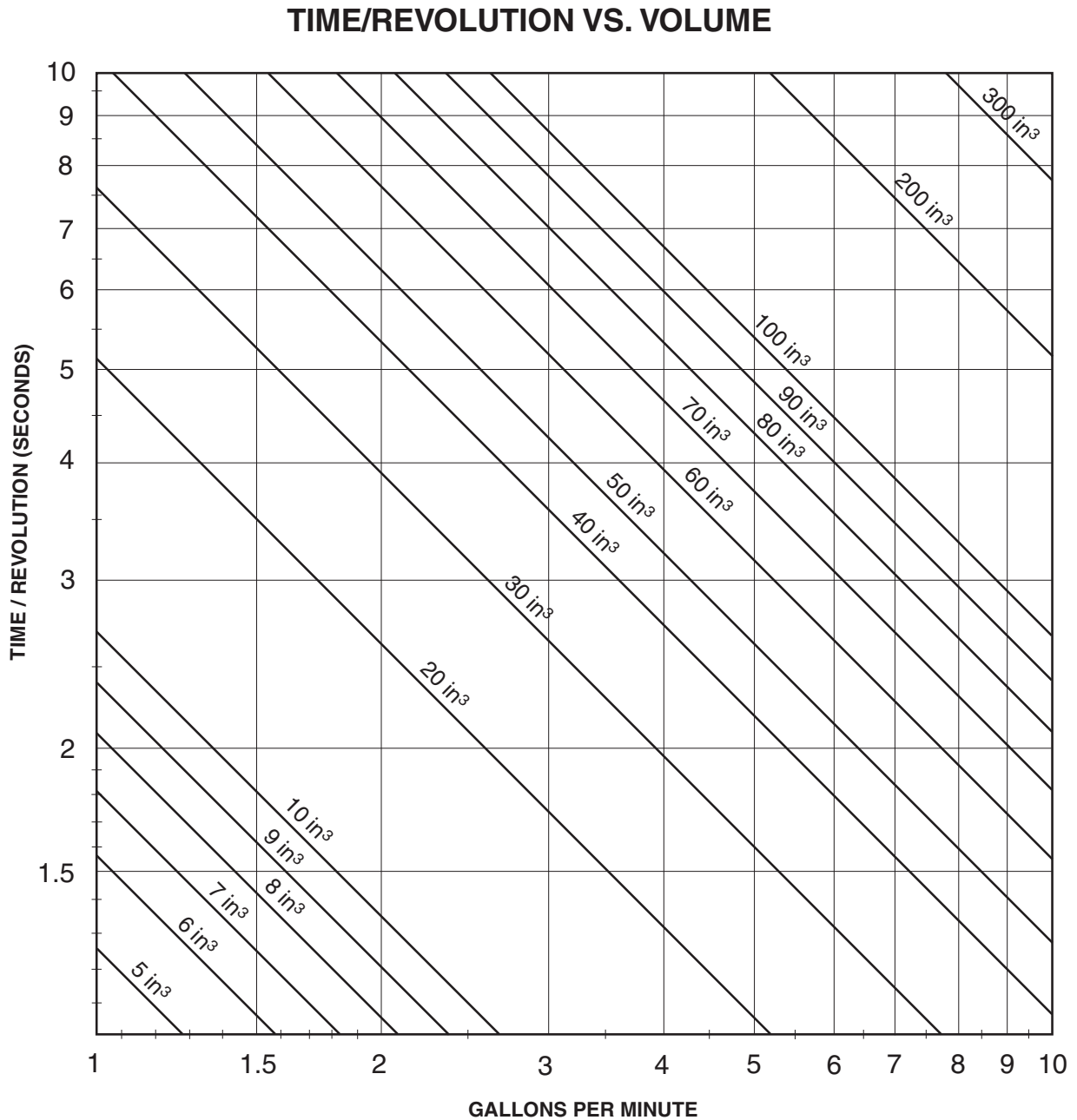

Figure 16

**Engineering**

**Composite Hydraulic Circuit**

When designing hydraulic operating circuits for rotary actuators, consideration should be given to the following criteria:

1. actuator rotational velocity
2. kinetic energy developed
3. actuator holding requirement
4. system filtration

Figure 17 is a composite drawing showing general recommendations for sample circuitry. It is intended as a guide only. Flow control valves (1) in the meter-out position provide controlled actuator velocity. Care should be taken if the load moves overcenter, as the combination of load and pump generated pressure may exceed the actuator rating.

To protect the actuator and other system components from shock pressures caused when the actuator is suddenly stopped in mid-stroke, crossover relief valves (2) should be installed as close to the actuator as possible. These relief valves also protect the actuator and system if the load increases and “back drives” the hydraulic system.

In applications involving high speeds or heavy loads, the built up kinetic energy may be too much for cushions to absorb during their 20° of operation. By using cam or lever operated deceleration valves (3) the deceleration arc can be increased beyond 20° so that kinetic energy can be absorbed more gradually and without overpressuring the actuator. Where there is a need to hold the load in intermediate positions for extended periods of time, pilot operated check valves (4) should be used. These must be used with leakproof actuator seals to hold the load in position; any bypass flow allows eventual drifting of the load.

**Warning: For safety reasons, some applications require a mechanical locking device for holding loads over an extended period of time.**

As with most standard hydraulic circuits, rotary actuator applications should have filtration to provide a continuous cleanliness rating of no more than 390 particles greater than 10 micron per milliliter of fluid. This is an ISO 17/14 fluid cleanliness classification. Filters (5) should be fitted and maintained to ensure this minimum level.

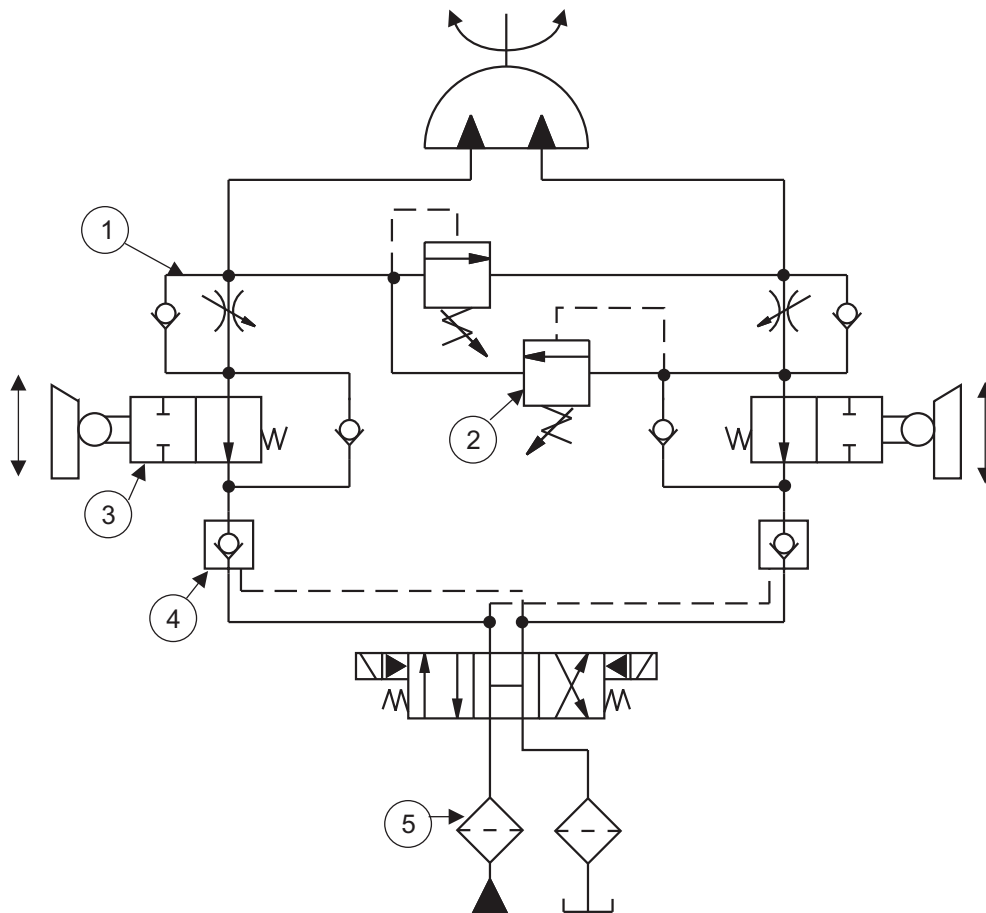

Figure 17 Hydraulic rotary actuator circuit

**Electrohydraulic Circuitry**

The use of electrohydraulic components for rotary actuator applications can provide greater system flexibility. Figure 18 is a representative circuit showing some possible applications of electrohydraulic valves. Proportional or servo control valves (1) can provide continuous position, velocity or acceleration control of loads, and “closing the loop” around a position feedback device and can provide even greater control and velocity profiles for overcenter or varying loads. Even more precise position control is possible with the use of vane actuators or anti-backlash devices on rack and pinion units.

Torque control can also be achieved with servovalve (1) by taking advantage of the valve's pressure gain region.

All of the considerations from the composite hydraulic circuit (Fig. 17) are still relevant. Crossover relief valves (3) should be installed if there are uncontrolled sudden stops in mid-stroke, and caution should be exercised when running overcenter, running with high speeds, or moving high inertia loads. Filtration (4) is still a consideration, but the actuator requirements (ISO 17/14 class) are usually less demanding than the filtration requirements of today's electrohydraulic control valves.

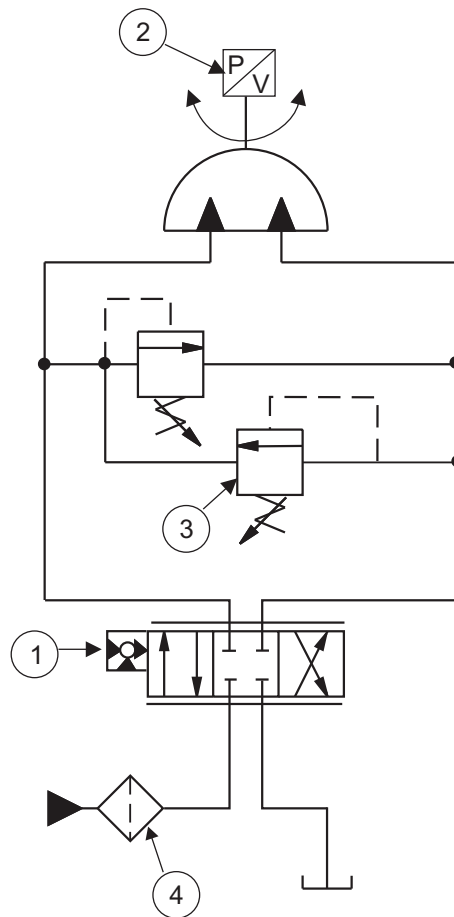

Figure 18 Electrohydraulic rotary actuator circuit

**Engineering**

## Installation Instructions and Options

### A. Stops

Vane units should not use the vane and stator as a positive stop. For light to medium loads, an internal taper lock stop, or external stops mounted to the machine framework, may be used. For high inertia or high speed loads, externally mounted valving or deceleration devices should be used to minimize system shocks.

Rack and pinion units can be stopped at the end of stroke provided the loads and speeds are not too high. Cushions can be used to decelerate the load to a gentle stop, providing the maximum actuator pressure rating is not exceeded by the cushions. Again, for high inertia or high speed loads, externally mounted valving or deceleration devices should be used to minimize system shocks.

### B. Surge Pressures

Surge or shock pressure in excess of the actuator rated pressure are detrimental to unit life and must be avoided. Cross-over relief valves mounted adjacent to the actuator can help reduce these abnormal pressure peaks.

Pressure developed by cushion or deceleration valves should also be kept below rated pressure.

### C. Angular Velocity

Angular velocity can be controlled by metering the flow into or out of the actuator ports. This can be accomplished by the use of flow control valves; or if more sophisticated control is required, through the use of proportional or servo valves.

Care should be taken when using a meter-out circuit if the load moves over center, as the combination of load and pump generated pressures may exceed the actuator rating.

### D. Drains

Some actuators are fitted with drain ports to minimize external leakage possibilities. These drain ports should be connected directly back to the oil reservoir with a minimum of back pressure (3.5 bar / 50 psi maximum).

### E. Gear Chamber

Some rack and pinion actuators are supplied with the gear chambers filled with a molybdenum disulfide grease to better absorb gear stress and extend gear life. This chamber should be checked and filled periodically to ensure adequate gear lubrication. The housing can be fitted with a small relief valve that vents excess pressure in the gear chamber to the atmosphere. This is an indication of pressure seal wear, because high pressure oil is bypassing the piston seal and pressuring the gear chamber. The piston seals should then be replaced.

### F. Fluid Medium and Seals

For hydraulic usage, a clean, filtered, high-quality mineral-based hydraulic fluid with 150 to 500 S.U.S. viscosity at 100°F is recommended for use with standard Buna N seals. Cleanliness should be maintained to an ISO code 17/14 level.

Standard seal compound is Buna N for mineral-based hydraulic fluid. Other seal materials can be provided for most operating fluids. If there is a question about the correct seal compound, provide the name and type of operating fluid to the actuator manufacturer and ask for their recommendation.

### G. Shaft Couplings

Couplings should engage the full length of the shaft keyway and pressure should only be applied after support has been provided on the opposite end of the shaft. Shafts should be within 0.005 TIR to ensure proper alignment.

**Contents**

---

**Maintenance and Service**

LTR Series ..... 2  
LTR Series Piston Seal ..... 7  
HTR Series ..... 8  
HTR Series Piston Seal ..... 11  
M Series ..... 12  
Tork-Mor ..... 17

*Additional information may be obtained from  
Pneumatic Division in Wadsworth, Ohio, or from the  
nearest Pneumatic Division Representative.*

## LTR Series Actuators

# Maintenance Instructions & Parts List

*Provide Model Number and Serial Number When Ordering Spare Parts.*

The LTR Series Actuators will provide superior performance in heavy duty pneumatic and medium duty hydraulic applications. The LTR Series "Wear-Pak" piston sealing configurations and anti-friction ball bearings are used to guarantee low breakaway pressure and eliminate erratic motion at low speeds.

In the event that maintenance is required, the following steps should be used as a guide. It is recommended that a suitable oil or O-ring lubrication compatible with the operating media, such as Parker Lube-A-Cyl, be used on all seals and mating parts to facilitate assembly.

### **A. Inspection & Replacement of Piston Seal, #10, Wear Rings, #15, and O-Ring End Cap, #12.**

1. Remove Tie Rod Nuts, #17 from Tie Rods, #8.
2. Pull End Cap, #16 free from Cylinder Tube, #14.
3. Pull Cylinder Tube, #14 free from Housing, #13.
4. Push Piston, #11 free from Cylinder Tube, #14.
5. Inspect and/or replace Piston Seal, #10, Wear Rings, #15, and O-Ring End Cap, #12.
6. Inspect and/or replace O-Ring Cylinder, #7 (for LTR Models only).
7. Reassemble as shown in figure and torque Tie Rod Nuts, #17 per Torque Table.

### **B. Inspection & Replacement of Bearing, #2.**

1. Remove Retaining Ring, #1.
2. Press Pinion, #3, and Bearing #2 from housing, #13.
3. Press Bearing, #2 free from Pinion, #3.
4. Inspect or replace Bearing, #2.
5. Press new Bearing, #2 into Housing, #13.
6. Replace Pinion, #3 into Housing, #13.
7. Press remaining new Bearing, #2 onto Pinion, #3.
8. Replace Retaining Ring, #1.

#### **NOTE:**

Prior to assembly of an LTR Series actuator, the rack and pinion are coated with a molycoat GN paste and a moly grease containing a minimum MSO<sub>2</sub> content of 3%, such as Texaco Molytex EP2.



ITEM NO.	DESCRIPTION	QUANTITY	
		SINGLE RACK	DOUBLE RACK
1	RETAINING RING	2	2
2	BEARING	2	2
3	PINION	1	1
4	NAME PLATE	1	1
6	PLUG	1	1
7*	O-RING, CYLINDER TUBE <sup>1</sup>	2	4
8	TIE ROD	8	16
9	RACK	1	2
10*	PISTON SEAL	2	4
11	PISTON	2	4
12*	O-RING, END CAP	2	4
13	HOUSING	1	1
14	CYLINDER TUBE	2	4
15*	WEAR RING	4	8
16	END CAP	2	4
17	TIE ROD NUT	8	16
18	BUMPER	1x	1x
19	BUMPER BOLT	1x	1x

**Bumper Option**

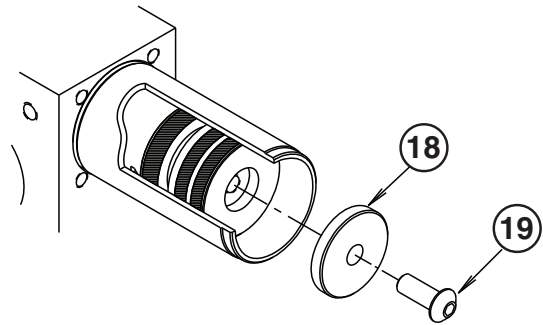

Built in polyurethane bumper pads absorb shock and noise, thus permitting faster cycle times and increased production rates. Recommended torque value for Bumper Bolt, item #19, is shown in Torque Table.

All items marked with an asterick (\*) are included in a complete seal kit.

<sup>1</sup> = Only used on units with steel cylinder tubes. (LTR units)

x = Quantity as required per end cap option specified.

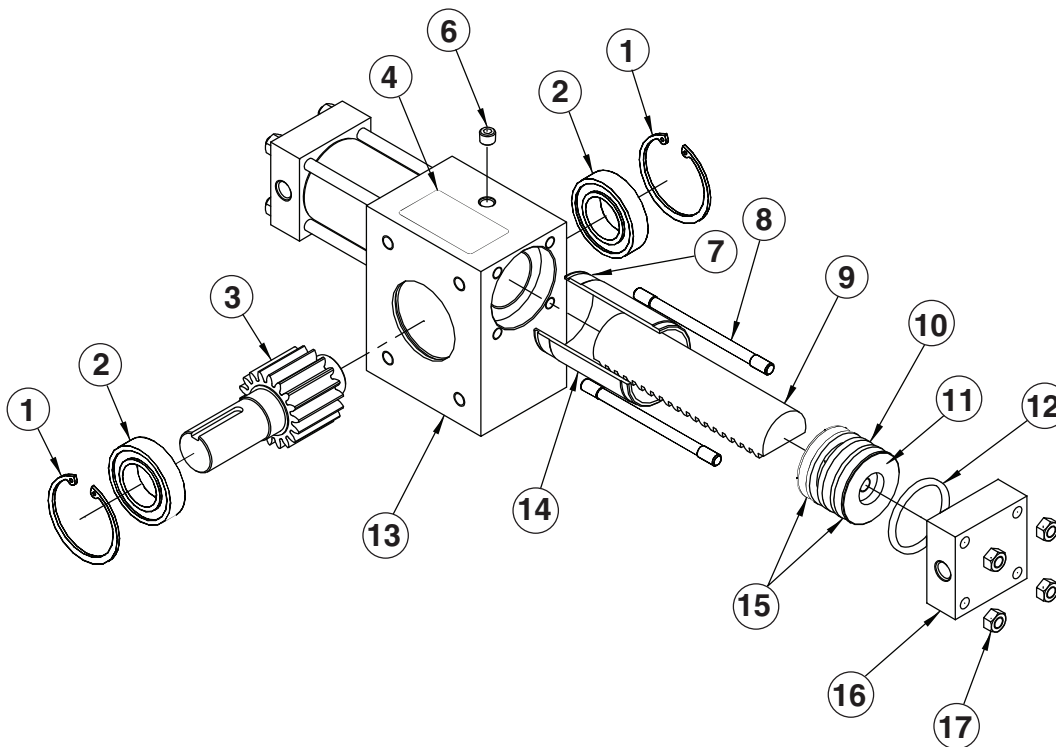

PTR/LTR MODEL	TIE ROD NUT #17		BUMPER BOLT #19	PISTON BOLT #36 CUSHION PLUG #25	SHAFT SEAL SCREW #50	FLANGE BOLT #46
	CYLINDER TUBE MATERIAL					
	ALUMINUM	STEEL				
101/102	1.5	—	3	3	3	5
151/152	3	5	6	6	3	10
201/202	6	11	20	20	3	17
251/252	6	11	20	20	3	40
321/322	15	20	50	50	3	130

**Cushion Option**

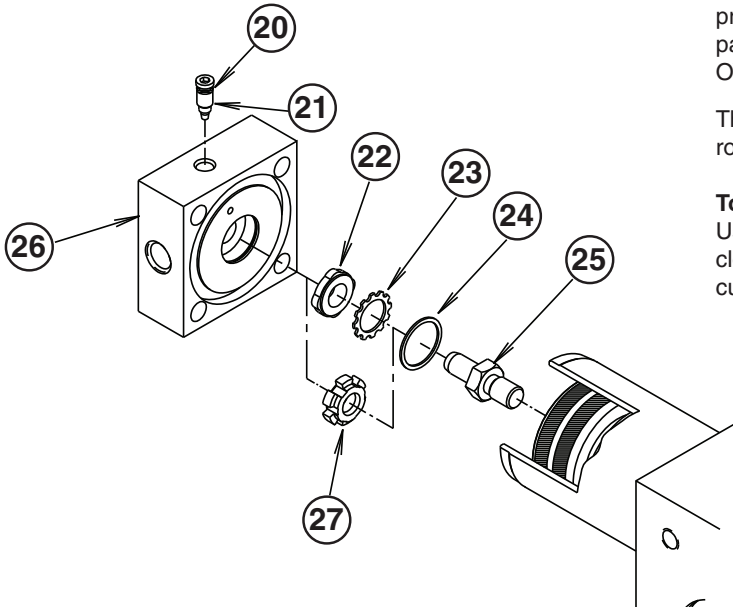

**CAUTION:**

Before making any adjustment, turn off the system pressure. Never adjust cushion adjustment screw out past flush with end cap or counterbore. **DO NOT OVERTIGHTEN.**

The standard cushions operate over the last 30° of rotation in either or both directions.

**To Adjust:**

Using an Allen wrench, turn Adjustment Screw, #21, clockwise for more cushioning, counterclockwise for less cushioning.

ITEM	DESCRIPTION	QTY.
20	O-RING, ADJUSTMENT SCREW	1
21	CUSHION ADJUSTMENT SCREW	1
22	CUSHION SEAL	1
23	CUSHION SEAL WASHER <sup>1</sup>	1
24	RETAINING RING <sup>1</sup>	1
25	CUSHION PLUG	1
26	END CAP	1
27	CUSHION BUSHING <sup>2</sup>	1
28	O-RING, ADJUSTMENT SCREW	1
29	FLOW CONTROL ADJ. SCREW	1
30	END CAP	1
31	PLUG	1
32	O-RING, PLUG	1
33	CHECK BALL	1
34	CHECK SPRING	1
35	CHECK PLUG	1

**NOTE:** Quantities shown are as required *per end cap option* specified.

<sup>1</sup> = Cushion seal configuration for use with pneumatic service.

<sup>2</sup> = Cushion bushing for use with hydraulic service.

**Port Flow Control Option**

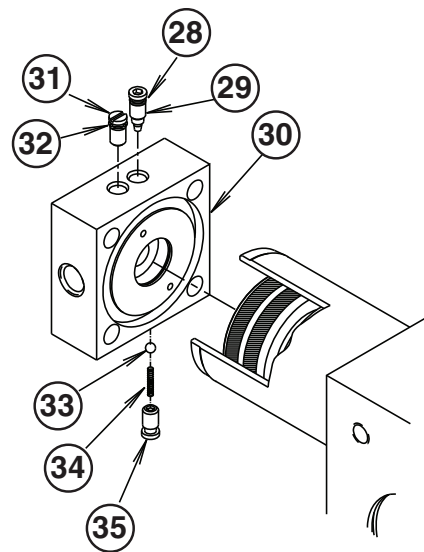

**Schematic**

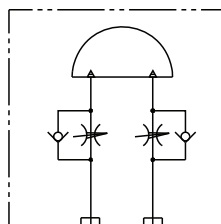

Built in meter-out flow controls provide for precise regulation of actuator speed and eliminate the cost and space of externally mounted components. A separate spring loaded ball check is used to provide free flow in the opposite direction.

When both cushions and port flow controls are specified they will be stamped "C" and "P" respectively.

**To Adjust:**

Using an Allen wrench, turn Adjustment Screw, #29, clockwise for slower speed; counterclockwise for more speed.

**Stroke Adjust Options**

Stroke adjusters will reduce the angle of rotation by 10° or 30° in either or both directions. Typical applications are for initial set up purposes where exact rotation requirements may change between various operations.

**CAUTION:** Before making any adjustments, turn off system pressure and ensure that no residual pressure exists in the actuator.

Standard cushions operate over the last 30° of rotation. Stroke adjusters will decrease the cushion length by the same amount. For example, reducing the rotation by 5° yields 25° cushion length.

**To Adjust:**

1. Loosen Jam Nut, #40.
2. Turn Stroke Adjuster, #41 clockwise to reduce stroke, counterclockwise to increase stroke.
3. Tighten Jam Nut, #40.
4. Resume system pressure.

PTR/LTR MODEL	ONE COMPLETE TURN OF ADJUSTER CAUSES SPECIFIED CHANGE IN ROTATION
101/102	4.0°
151/152	4.6°
201/202	3.2°
251/252	3.2°
321/322	2.4°

**30° Stroke Adjust Option**

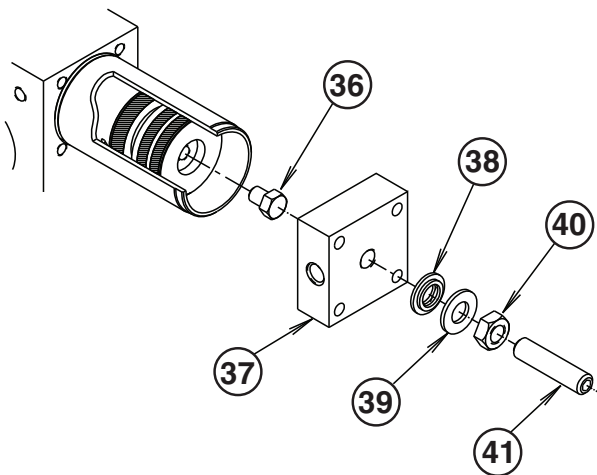

**30° Stroke Adjust Option with Bumper**

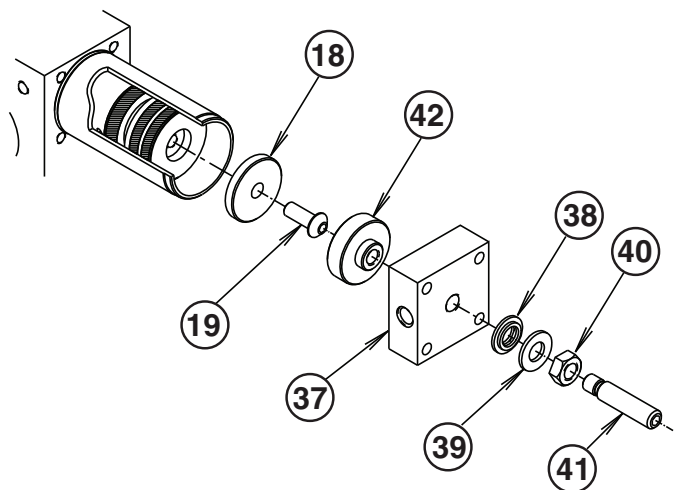

**10° Stroke Adjustment with Cushion Option**  
 (Single Rack Units Only)

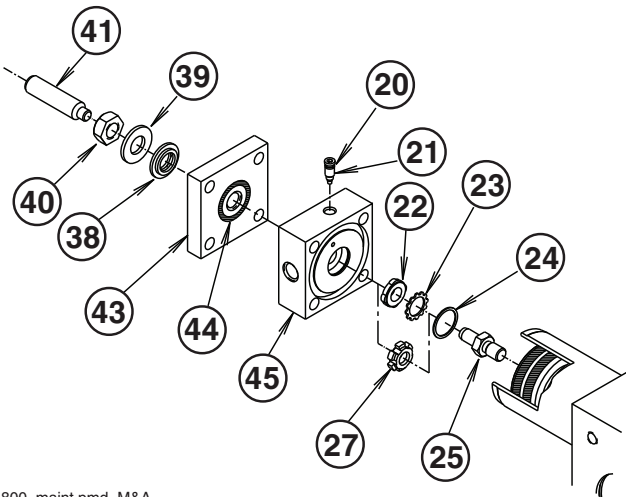

ITEM	DESCRIPTION	QTY.
36	PISTON BOLT	1
37	END CAP	1
38	THREAD SEAL	1
39	LOCK WASHER	1
40	JAM NUT	1
41	STROKE ADJUSTER	1
42	STROKE ADJUST HEAD	1
43	STROKE ADJUST BLOCK	1
44	O-RING, STROKE ADJUST BLOCK	1
45	END CAP	1

**NOTE:** Quantities shown are as required *per end cap* option specified.

**Mounting Options**

Mounting options utilize existing face and base mounting holes.

Shaft seal covers are designed to prolong bearing life by isolating them from external contamination and pressure.

**NOTE:** <sup>1</sup> = Quantity is 2 if double-end shaft extension is specified.  
<sup>2</sup> = Quantity is 0 if double-end shaft extension is specified.

ITEM	DESCRIPTION	QTY.
46	FLANGE BOLT	4
47	FRONT FLANGE	1
48	FOOT FLANGE	1
49	PILOT RING	1
50	SHAFT SEAL COVER SCREW	6
51	SHAFT SEAL	1 <sup>1</sup>
52	O-RING	2
53	SHAFT SEAL COVER WITH HOLE	1 <sup>1</sup>
54	SHAFT SEAL COVER, SOLID	1 <sup>2</sup>

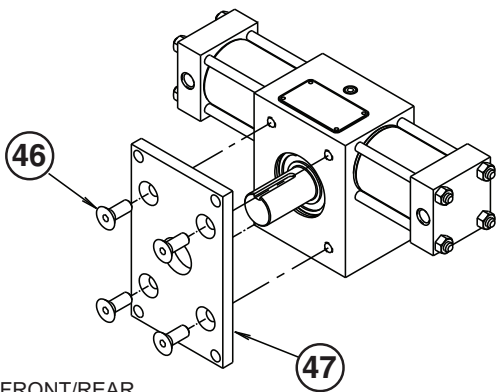

FRONT/REAR  
 FLANGE MTG.

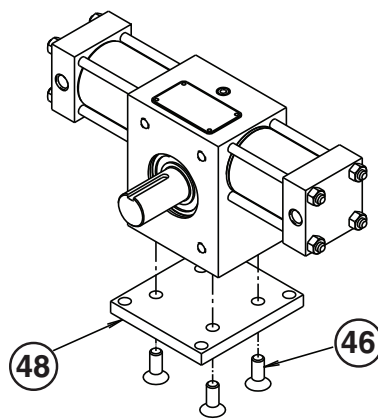

FOOT  
 FLANGE MTG.

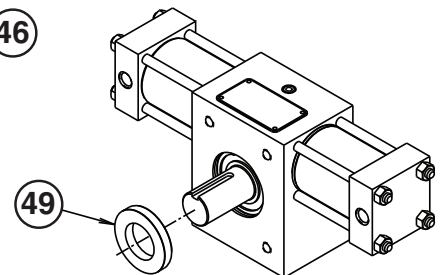

PILOT RING MTG.

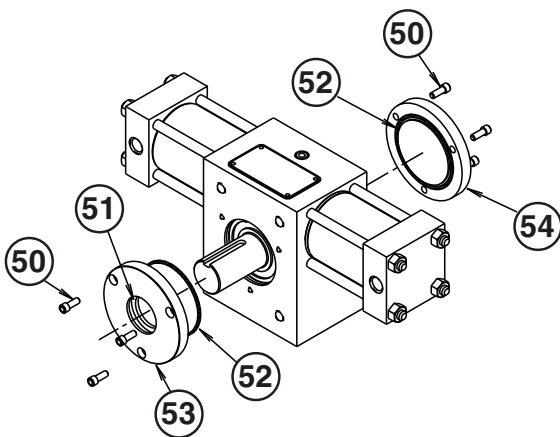

SHAFT SEAL COVER  
 OPTIONS 'S'

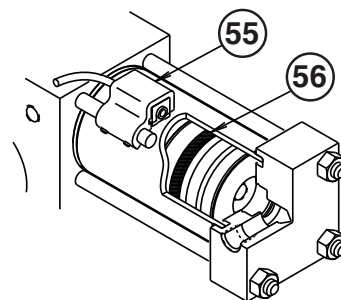

See next page for details on Items 55 & 56.

MAGNET PISTON RING  
 OPTION 'M' W/SWITCH  
 (ORDER SWITCH SEPARATELY)

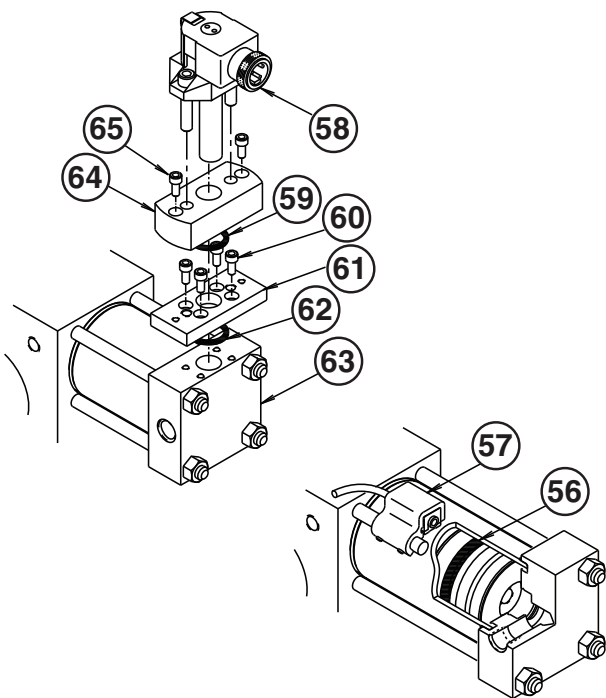

ITEM	DESCRIPTION	QTY.
55	REED SWITCH KIT (Lead Type or Quick Connect)	1
56	Magnet	2
57	HALL EFFECT SWITCH KIT (Lead Type or Quick Connect)	1
58	PROXIMITY SWITCH	1
59	O-RING, ADAPTER BLOCK	1
60	SCREW, SPACER BLOCK	4
61	SPACER BLOCK	1
62	O-RING, SPACER BLOCK	1
63	END CAP	1
64	ADAPTER BLOCK	1
65	SCREW, ADAPTER BLOCK	2

**NOTE:** Quantities shown are as required *per end cap* option specified.

### Seal Kit Ordering Information

- Standard units are equipped with Nitrile seals.
- Optional seal compounds are available.
- See parts list for items contained in seal kit.
- Seal kit part numbers as shown:

<b>PSK</b> Parker Seal Kit	—	<b>LTR322</b> Base Model	<b>V</b>
			Omit - Standard V = Fluorocarbon Q = Quad Ring Piston Seals W = Carboxilated Nitrile Piston Seals

**NOTE:** This seal kit contains parts to reseal Design Series "A", "B" or "C" LTR Series rotary actuators. If your actuator is a "C" Design Series, use the seals and wear bands provided to assemble the pistons as shown below left. If your actuator is Design Series "A" or "B", only the piston seal is required, as there will not be grooves to accept wear bands on these pistons. Assemble the piston seal provided in the groove which will be closest to the fluid pressure when the piston is reinstalled, as shown below right. Although these pistons have two seal grooves, the superior design of the piston seals which are now being utilized allows for more efficient performance than possible with the old design. Contact the factory or your local representative for information on how to update "A" or "B" Design actuators.

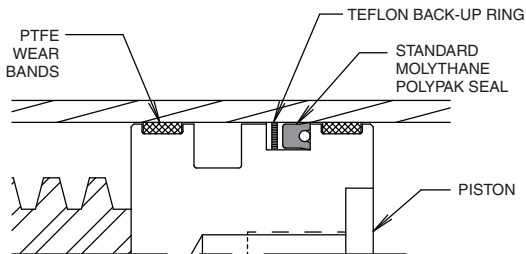

**Design Series "C"**

LTR Series rotary actuators with Design Series suffix "C" at the end of the model number have the piston/piston sealing configuration illustrated above. Each piston is equipped with two non-metallic wear bands and one standard Molythane Polypak seal with backup ring for superior wear resistance.

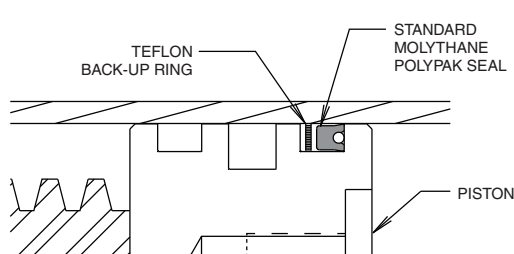

**Design Series "A" & "B"**

LTR Series rotary actuators with Design Series suffix "A" or "B" at the end of the model number should be reassembled with the piston/piston sealing configuration illustrated above. These models were originally equipped with two standard pneumatic lip seals with Teflon backup rings; this configuration is replaced with one standard Molythane Polypak seal with Teflon backup ring.

## HTR Series Actuators

**Maintenance Instructions & Parts List***Provide Model Number and Serial Number When Ordering Spare Parts.***GENERAL**

HTR Series Hydraulic Rack & Pinion Actuators are designed for a maximum operating pressure of 3,000 psi non-shock.

The actuator consists of a Pinion and one or two Racks located within a Housing. Pressurization of alternate cylinder port(s) results in shaft rotation.

The gear chamber has been filled with a Moly grease containing a minimum Molybdenum Disulfide (MSO<sub>2</sub>) content of 3%.

In the event that maintenance is required, the following steps should be used as a guide:

**ASSEMBLY AND DISASSEMBLY PROCEDURES**

- A. Inspection & Replacement of End Cap Seals, #9.
- Place actuator in the mid-stroke position as shown. Remove Tie Rod Nuts, #10, from Tie Rods, #13.
  - Pull End Cap, #11, free from Cylinder Tube, #12.
  - Inspect and/or replace End Cap O-Ring, #9. Lubricate Seal and End Cap before reinstalling.
  - Replace End Cap, #11, on Cylinder Tube, #12, and assemble Tie Rod Nuts, #10 to Tie Rods, #13.
  - Torque Tie Rod Nuts per table.
- B. Inspection & Replacement of Wear Rings, #4, Piston Seals, #5, and Cylinder O-Ring, #8.
- Repeat Steps A1 and A2.
- For Models HTR75 through HTR 600:
- Remove Rack Bolt, #7.
  - Screw two (2) threaded rods into the tapped holes in Piston, #16, and pull free from Cylinder Tube, #12.
- For Models HTR.9 through HTR45:
- Pull Cylinder Tube, #12, free from Housing, #2.
  - Remove Rack Bolt, #7.
- For All Models
- Inspect Piston, #16, and replace Piston Seal, #5.
  - Inspect and/or replace Wear Rings, #4.
  - Inspect and/or replace Cylinder O-Ring, #8.
  - Replace Cylinder Tube, #12 to Housing, #2.
  - Slide Piston, #16, with Piston Seal and Wear Rings assembled onto it, into Cylinder Tube, #12, until it contacts Rack, #17.
11. Replace Rack Bolt, #7 and torque per table.  
**Caution:** Nylon Slug, #6, is designed to prevent Rack Bolt from vibrating loose during operation; replace as required.
12. Replace End Cap, #11, and Tie Rod Nuts, #10; torque per table.
- C. Inspection and Replacement of Pinion and Bearing Retainer O-Rings, #1 and #24.
- Loosen Lock Screw, #19.  
**Caution:** Failure to do so will damage threads.
  - Using spanner wrench, remove Bearing Retainer, #25, by turning counter-clockwise.
  - Remove Bearings, #22, and Pinion, #23.  
**Caution:** Make match marks to re-establish the correct timing.
  - Inspect and/or replace Pinion O-Ring, #1, located at the "front" or blind side of Housing #2.
  - Reinstall Bearings, #22, and Pinion #23.
  - Inspect and/or replace Bearing Retainer O-Ring, #24, located on outside diameter of Bearing Retainer, #25.
  - Inspect and/or replace Pinion O-Ring, #1, located on inside diameter of Bearing Retainer, #25.
  - Apply Moly Grease to Bearing Retainer Threads and reinstall into Housing, #2.
  - Torque Bearing Retainer, #25 per table.
  - Install and tighten Locking Screw, #19, per torque table.
- D. Complete Disassembly of Actuator.
- Repeat Steps A1 and A2.
  - Repeat Steps B2 through B5.
  - Repeat Steps C1 and C3.
  - Caution:** Make match marks to re-establish the correct timing.
  - Push Rack from either end to remove from housing.
- E. Reassembly of Actuator.
- Follow previous procedures for reassembly of all actuator parts. Refill the gear chamber with Moly Grease with a minimum MSO<sub>2</sub> content of 3%; such as Texaco Molytex EP2.

MODEL	ONE COMPLETE TURN OF ADJ. CAUSES SPECIFIED CHANGING IN ROTATION
HTR.9/1.8	4.0°
HTR3.7/7.5	3.3°
HTR5/10	2.5°
HTR15/30/22/45	2.0°
HTR75/150	2.0°
HTR300/600	1.2°

MAXIMUM UNIT ROTATION IS EQUAL TO ROTATION SPECIFIED IN THE MODEL CODE.

ADJUSTERS ALLOW ROTATIONAL POSITIONING EQUAL TO OR LESS THAN MAXIMUM ROTATION.

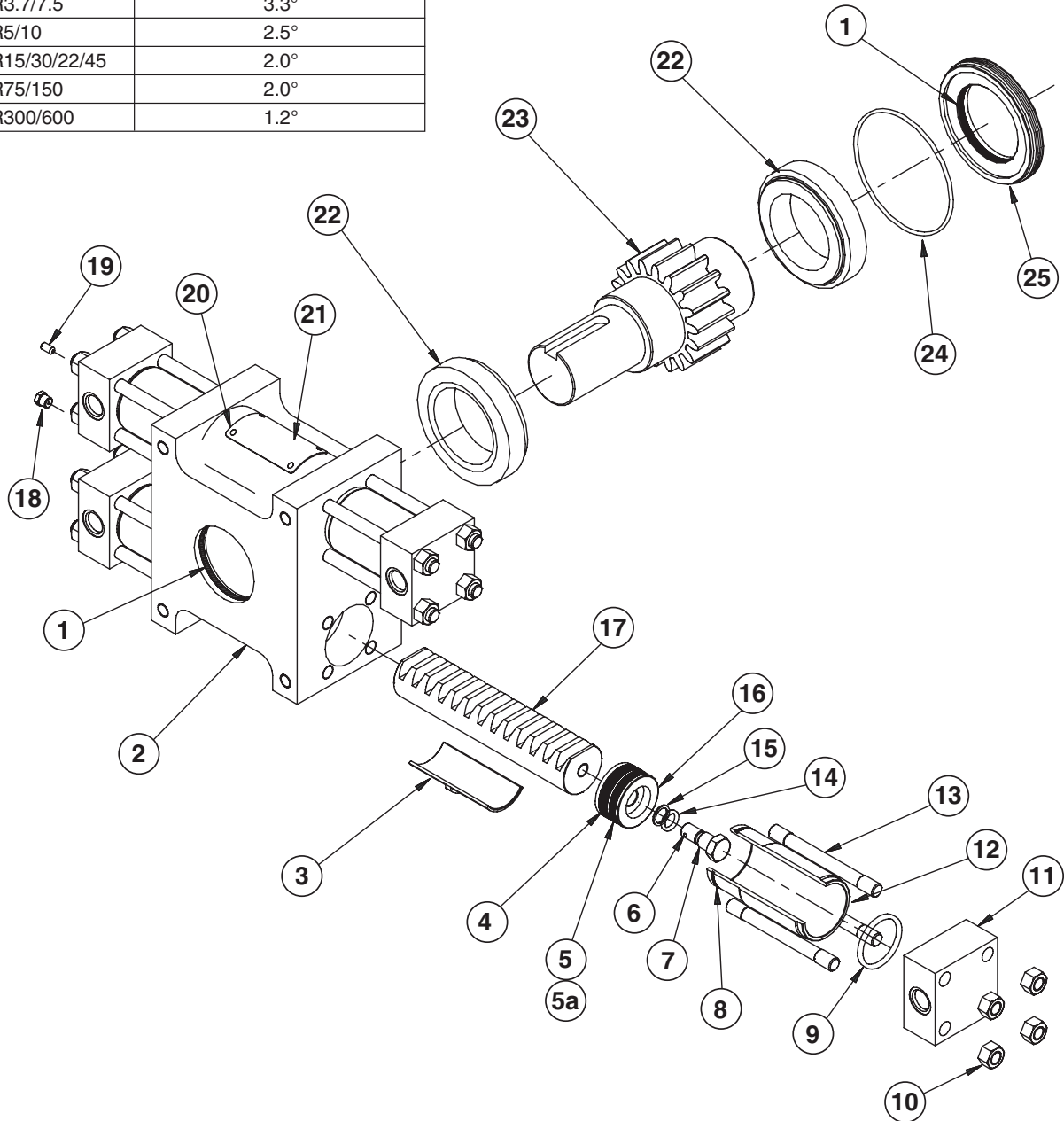

MODEL	TIE ROD NUT #10	RACK BOLT #7 CUSHION PLUG #31	BEARING	LOCKING SCREW #19
HTR.9/1.8	6	3	15	2
HTR3.7/7.5	15	15	30	4
HTR5/10	15	15	50	4
HTR15/30	30	40	100	4
HTR22/45	45	40	100	4
HTR75/150	130	130	250	15
HTR300/600	525	360	500	15

ITEM NO.	DESCRIPTION	QUANTITY	
		SINGLE RACK	DOUBLE RACK
1*	O-RING, PINION	2	2
2	HOUSING	1	1
3	RACK BEARING	1	2
4*	WEAR RING	2	4
5*	PISTON SEAL	2	4
5a*	BACK-UP RING	2	4
6	NYLOK SLUG	2	4
7	RACK BOLT	2	4
8*	O-RING CYLINDER	2	4
9*	O-RING, END CAP	2	4
10	TIE ROD NUT	8	16
11	END CAP	2	4
12	CYLINDER TUBE	2	4
13	TIE ROD	8	16
14*	O-RING, RACK BOLT	2	4
15*	BACK-UP RING, RACK BOLT	2	4
16	PISTON	2	4
17	RACK	1	2
18	RELIEF VALVE	1	1
19	LOCKING SCREW	1	1
20	DRIVE SCREW	4	4
21	NAME PLATE	1	1
22	BEARING	2	2
23	PINION	1	1
24*	O-RING, BEARING RETAINER	1	1
25	BEARING RETAINER	1	1

**NOTE:**

- Items marked with an asterisk (\*) included in a seal repair kit.
- 5a (BACK-UP RING) used only with Viton Seals.

**Cushion Option**

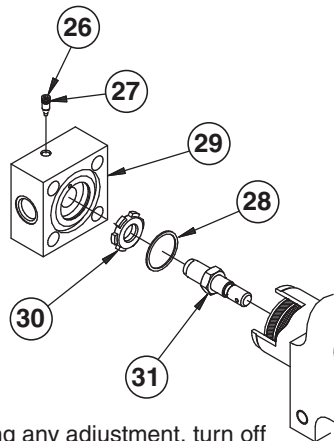

**Caution:** Before making any adjustment, turn off the hydraulic pressure. Never adjust Cushion Screw out past flush with End Cap or counterbore. **DO NOT OVERTIGHTEN.**

Adjustable cushions are designed to cushion the last 20° of actuator stroke.

**To Adjust:**

Using an Allen wrench, turn Adjustment Screw, #13, counter clockwise for less cushioning.

**Stroke Adjust Option**

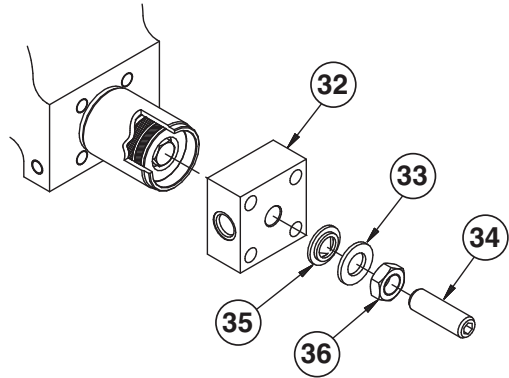

**Caution:** Before making any adjustment, turn off the hydraulic pressure. To Adjust:

1. Loosen Jam Nut, #31.
2. Turn Stroke Adjusters, #30, CW to reduce stroke, CCW to increase stroke.
3. Tighten Jam Nut, #31.
4. Resume system pressure.

**Cushion and Stroke Adjust Option**

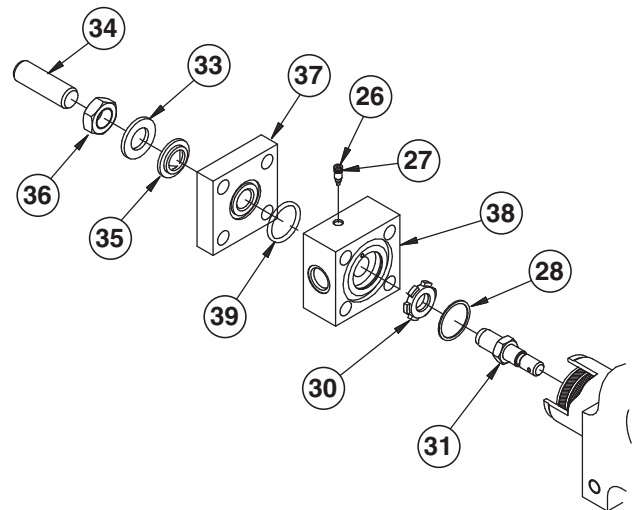

ITEM NO.	DESCRIPTION	QUANTITY
26	CUSHION ADJUSTMENT SCREW	1
27	O-RING, ADJUSTMENT SCREW	1
28	RETAINING RING	1
29	END CAP	1
30	CUSHION BUSHING	1
31	CUSHION PLUG	1
32	END CAP	1
33	WASHER	1
34	STROKE ADJUSTER	1
35	THREAD SEAL	1
36	JAM NUT	1
37	STROKE ADJUST BLOCK	1
38	END CAP	1
39	O-RING, STROKE ADJUST BLOCK	1

**NOTE:** Quantities required are per end cap option specified.



**Proximity Switches**

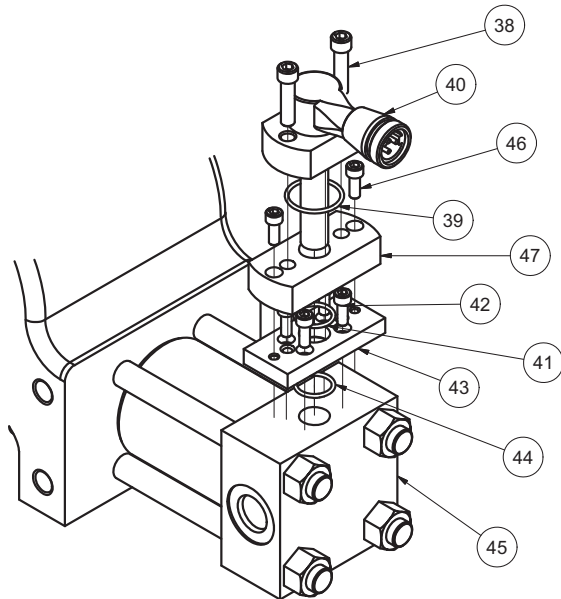

Parts List		
ITEM NO.	DESCRIPTION	QTY
38	BOLT, PROXIMITY SWITCH	2
39	O-RING, PROXIMITY SWITCH	1
40	PROXIMITY SWITCH	1
41	O-RING, SPACER BLOCK	1
42	BOLT, ADAPTOR BLOCK	4
43	ADAPTOR BLOCK	1
44	O-RING, ADAPTOR BLOCK	1
45	END CAP	1
46	BOLT, SPACER BLOCK	2
47	SPACER BLOCK	1

Quantities required are per end cap.

**NOTES:**

1. Available with or without cushions.
2. Not available with stroke adjusters.
3. Pressure rating: 3000 psi
4. Operating temperature: -4°F to 158°F
5. Specify end cap position (1, 2, 3, 4), switch type, and voltage when ordering.
6. Switch Types:  
 EPS-7 . . . . .Voltage 20 to 250 VAC/ DC  
 EPS-6 . . . . .Voltage 10 to 30 VDC

**Seal Kit Ordering Information**

- Standard units are equipped with nitrile seals.
- Optional seal compounds are available.
- See parts list for items contained in seal kits.
- Seal kit part numbers as follows:

<b>PSK</b> Parker Seal Kit	—	<b>HTR.9</b> Base Model	<b>V</b>
			Omit = Standard V = Fluorocarbon W = Carboxilated Nitrile Piston Seals

**NOTE:** The seal kit is equipped with parts necessary to re-seal Design Series "A", "B" or "C" HTR Series rotary actuators.

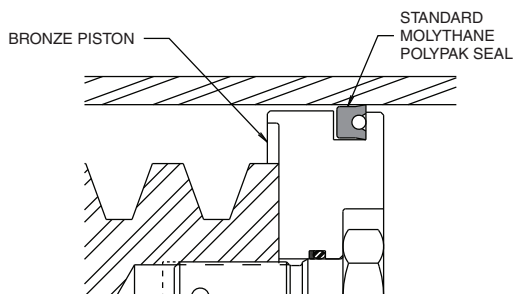

**Design Series "A" or "B"**

HTR Series rotary actuators with a Design Series suffix of "A" or "B" at the end of the model number should be re-assembled with the piston/pistonsealing configuration illustrated above. These models are equipped with a bronze piston and one "standard" Molythane Polypak piston seal.

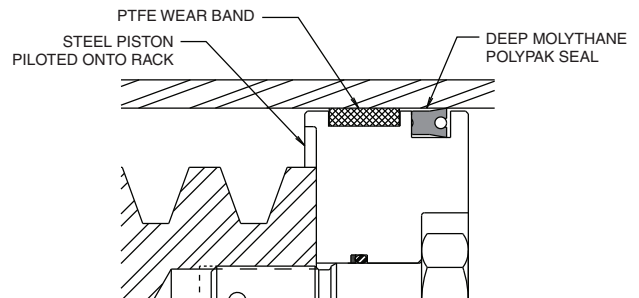

**Design Series "C"**

HTR Series rotary actuators with a Design Series suffix of "C" at the end of the model number have the piston/piston sealing configuration illustrated above. Each piston is equipped with one non-metallic wear band and one "deep" Molythane Polypak piston seal for superior wear resistance.

## M Series Actuators

## Maintenance Instructions &amp; Parts List

*Provide Model Number and Serial Number When Ordering Spare Parts.*

**General**

Limit the maximum operational pressure of the Parker M series rotary actuator to 3000 PSIG. Refer to the engineering catalog for operational specifications.

The actuator consists of the: rotary group which includes the rack gear and cylinder tubes; the pinion gear; the end cap group; the housing group; and the seal group.

The actuator rotates CCW when (facing the output shaft or mounting face) the lower left (and upper right) cylinder ports receive flow from a suitable power unit. Likewise, the actuator rotates CW when the lower right (and upper left) cylinder ports receive flow from a suitable power unit.

AAD lubricates the gear train with an EP grease that has a minimum MOS2 content of 3%. The factory installs TEXACO MOLYTEX EP(2) extreme pressure grease at assembly and test. If necessary, replenish the gear box lubricant with either MOLYTEX EP(2) lubricant or an equivalent.

Lubricant leakage from the housing relief valve is a symptom of a damaged piston seal and/or the cylinder tube bore. The urgency of repair depends upon the actuator's duty cycle and the rate at which the lubricant leaks from the housing. The typical repair involves replacing the piston seals; smoothing out any minor damage in the cylinder bore or replacing severely damaged cylinder tubes; and replacing or replenishing

the gear lubricant. Any good quality EP grease similar to TEXACO MOLYTEX EP(2) grease would be suitable.

In the event that a maintenance repair is needed, then we suggest using the following (outline) steps:

**A. Inspection and Replacement of the End Cap O-Ring (14) and Back Up Ring (15)**

1. Rotate shaft to mid-stroke position. Remove the end cap bolts (2) and the flat washers (3).
2. Screw threaded rod into tapped holes of end cap (16) and push end cap (16) into cylinder tube (29) and stop when you see the keeper ring (17).
3. Remove the keeper ring (17) by moving the short sides of the keeper rings radially into the cylinder; then move the larger top and bottom sides the same way.
4. Pull the end cap (16) out of the cylinder tube.
5. Cushion equipped end caps: remove adjusting screw (40.)

**Assembly**

(Omit steps 6 & 7 if end cap is not equipped with the cushion feature.)

6. Inspect adjusting screw o-ring (39); replace if necessary.
7. Install cushion adjusting screw into cushion equipped end cap.
8. Inspect end cap o-ring (14) and back up ring (15); replace if necessary. Note that the back up ring must be installed opposite the high pressure side of the o-ring.
9. Install end cap (16) into the cylinder tube (29) and push into position described in section A2.
10. Install the keeper ring (17) by positioning the large top and bottom segments and then the short segments. If necessary, suggest using a grease or vasoline as an installation aid to hold the segments in place.
11. Pull end cap (16) back into position against keeper ring.
12. Install the end cap bolts (2) and flat washers (3).
13. Apply proper torque to secure end cap assembly.

**B. Inspection & Replacement of Piston Seal (12)**

1. Follow steps 1, 2, 3 & 4 from section A.
2. Remove rack bolt (18) or remove cushion spear (35).
3. Install the piston (13) into the cylinder (29) and push until the piston is flush against the face of the rack gear (28).
4. Screw threaded rod into tapped holes in piston (13).
5. Pull piston, piston seal (12), and wear ring (11) free from cylinder (29).
6. Inspect and if necessary, replace the piston seal. (Polypak o-ring must face toward the high pressure side.) Replace the wear ring (11) if necessary.
7. Inspect and replace rack bolt or cushion spear o-ring seal (19) and back up ring (20). Replace if necessary. Install the back up ring opposite the pressure side.
8. Install the rack bolt (18) or the cushion spear (35) and tighten with the appropriate torque value presented in the table.

**CAUTION:** The nylok slug (21) is used to help the rack bolt or cushion spear resist loosening caused by vibration. Ensure the nylok slug is properly installed into the rack bolt or cushion spear prior to assembly. Replace if necessary.

9. Follow steps 6 through 13 from section A to install the end cap.

**C. Inspection and Replacement of Bearing Cap O-Ring (31) and Pinion O-Ring (33).**

1. Remove bearing cap bolts (5) and lock washers (6).
2. Pull bearing cap (4) from the housing (1).  
**CAUTION:** Use two bearing cap bolts (5) as "jacking screws" by screwing into the tapped holes in the bearing cap (4). Use wrench to "lift" the bearing cap out of the housing.
3. Mark witness marks on the pinion. Remove bearings (32) and pinion (34). Mark witness marks on the pinion (34) and rack gear (28) to ensure correct timing at assembly.
4. Inspect and replace pinion o-rings (33) in bearing cap (4) and in housing (1) if necessary.
5. Install bearings (32) and pinion (34) in housing. Pay attention to the witness marks so correct timing is achieved.
6. Inspect and replace bearing cap o-ring (31) if necessary.
7. Install bearing cap (4) and bearing cap bolts (5) with lock washers (6). Fasten bolts to torque values indicated in the table.

**Bearing Preload Procedure 'M' Series Rotary Actuators**

1. After reassembly of actuator, torque bearing cap bolts, item #3, to the value given in the torque table on page 95.
2. Loosen bearing cap bolts and retighten to approximately 1/2 of the recommended torque value.
3. Using a feeler gauge, measure the gap between the bearing cap and housing created by the loosening of the bolts in step #2.
4. Add shims as required per the measurement taken. If shimming can not be obtained to the exact measured amount, get as close as possible without going over the measured thickness required.

**Note:** shim thickness available: .005", .015"

**D. Disassembly of Actuator. Procedure for Removal, Inspection and Replacement of Rack Bearing (27).**

1. Follow suggested instructions 1, 2, and 3 from section C to remove bearing cap (4), bearings (32), and pinion (34).  
**CAUTION:** Mark witness marks on the pinion (34) and rack gear (28) to ensure correct timing at assembly.
2. Follow suggested instruction 1, 2, 3, 4, and 5 from section B.

3. Remove keeper flange bolts (22) and keeper flange lock washers (23).
4. Remove keeper ring (25) by sliding keeper flange (24) along cylinder (29) until keeper ring (25) is exposed. Remove both sections of the keeper ring.
5. Pull cylinder (29) from housing (1).
6. Slide keeper flange (24) from cylinder (29).
7. Inspect and replace cylinder o-ring (26) if necessary.
8. Slide rack (28) out of the housing.  
**CAUTION:** Use care not to damage the rack bearing. Ensure the rack gear teeth remain opposite from the rack bearing (27).
9. Inspect and replace rack bearing (27) if necessary.  
**CAUTION:** Ensure the rack bearing remains centered in the housing.
10. Install rack gears (28). Ensure the rack gear is slid into place. Suggest using grease or vasoline to hold the rack bearing in place during rack installation. Center the rack gear inside the housing. Use generous amounts of EP2 grease or equivalent to coat and ensure the gear train is properly lubricated during operation.
11. Assemble keeper flange (24) and the keeper ring (25) on to the cylinder (29). Install keeper ring (25) in slot of cylinder (29) and the slide keeper flange (24) over keeper ring (25). Slide assembly into the housing.
12. Install keeper flange bolts (22) and lock washers (23). Fasten keeper flange bolts (22) to torque values specified in the table.
13. Repeat steps 4, 5, 6 and 7 from section C.
14. Repeat steps 7, 8 and 9 from section B.
15. Ensure housing has a generous amount of lubricant. Install the housing relief valve (10).

**Caution:**

**Do not pump housing completely full of grease. Only a generous amount of lubricant is required. This will eliminate the potential of filling the "non-pressure" side of the cylinder tubes with grease.**

**Additional information may be obtained from the PNEUMATIC DIVISION in Wadsworth, Ohio or from the nearest authorized PARKER HANNIFIN Distributor or Representative.**

ITEM	DESCRIPTION	QUANTITY	
		SINGLE	DOUBLE
1	Housing	1	1
2	Bolt, End Cap	4	8
3	Flat Washer, End Cap	4	8
4	Bearing Cap	1	1
5	Bolt, Bearing Cap	8	8
6	Lockwasher, Bearing Cap	8	8
7	Plug, Housing	1	1
8	Name Plate, Housing	1	1
9	Drive Screw, Name Plate	4	4
10	Relief Valve, Housing	1	1
11*	Wear Ring, Piston	2	4
12*	Piston Seal	2	4
13	Piston	2	4
14*	O-Ring, End Cap	2	4
15*	Back-up ring, End Cap	2	4
16	End Cap	2	4
17	Keeper Ring, End Cap	2	4
18	Rack Bolt	2	4
19*	O-Ring, Rack Bolt	2	4
20*	Back-up Ring, Rack Bolt	2	4
21	Nylon Slug, Rack Bolt	2	4
22	Bolt, Keeper Flange	16	32
23	Lockwasher, Keeper Flange	16	32
24	Keeper Flange	2	4
25	Keeper Rings	2	4
26*	O-Ring, Cylinder	2	4
27	Rack Bearing, Housing	1	2
28	Rack	1	2
29	Cylinder	2	4
30‡	Shim	2	2
31*	O-Ring, Bearing Cap	1	1
32	Bearing	2	2
33*	O-Ring, Pinion	2	2
34	Pinion	1	1
35+	Cushion Plug	1	1
36+	Retainer Ring	1	1
37+	Cushion Bushing	1	1
38+	Plug, End Cap	1	1
39+*	O-Ring, Adjust Screw	1	1
40+	Cushion Adjusting Screw	1	1
41	Set Screw	2	4
42**	Air Bleeder	2	4

- \* Item Included in Seal Kit
- \*\* If Unit is Equipped With "G" Option (Air Bleeds)
- + For Cushion in One Direction, Qty. 1  
 For Cushion in Both Directions, Qty. 2  
 On Double Rack for Cushion in Both Directions, Qty. 4
- ‡ Total Shims = 2 (1 of each, or as required)  
 1 Shim = 0.005" Thick  
 1 Shim = 0.015" Thick

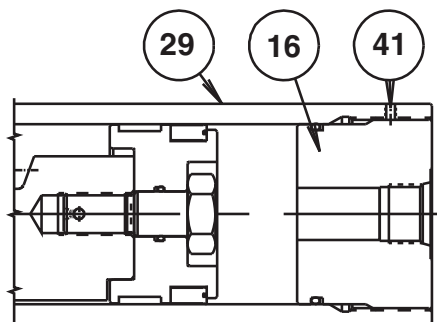
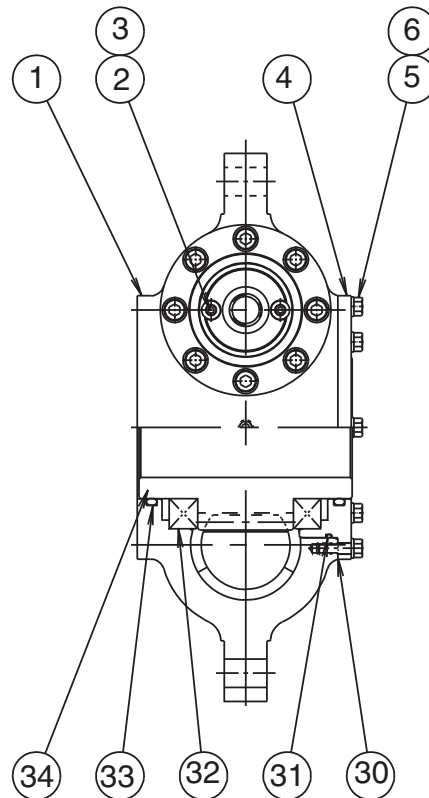

**5° Stroke Adjust Option**  
**Caution:** Do not adjust out past flush position

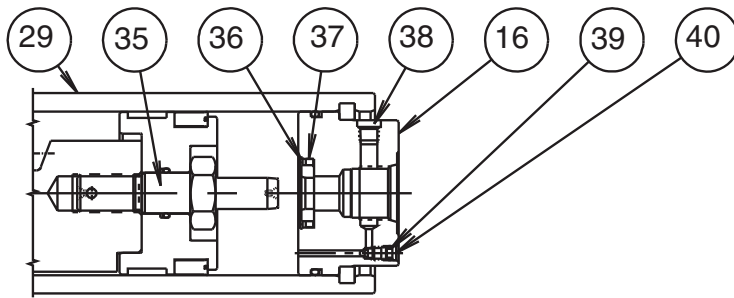
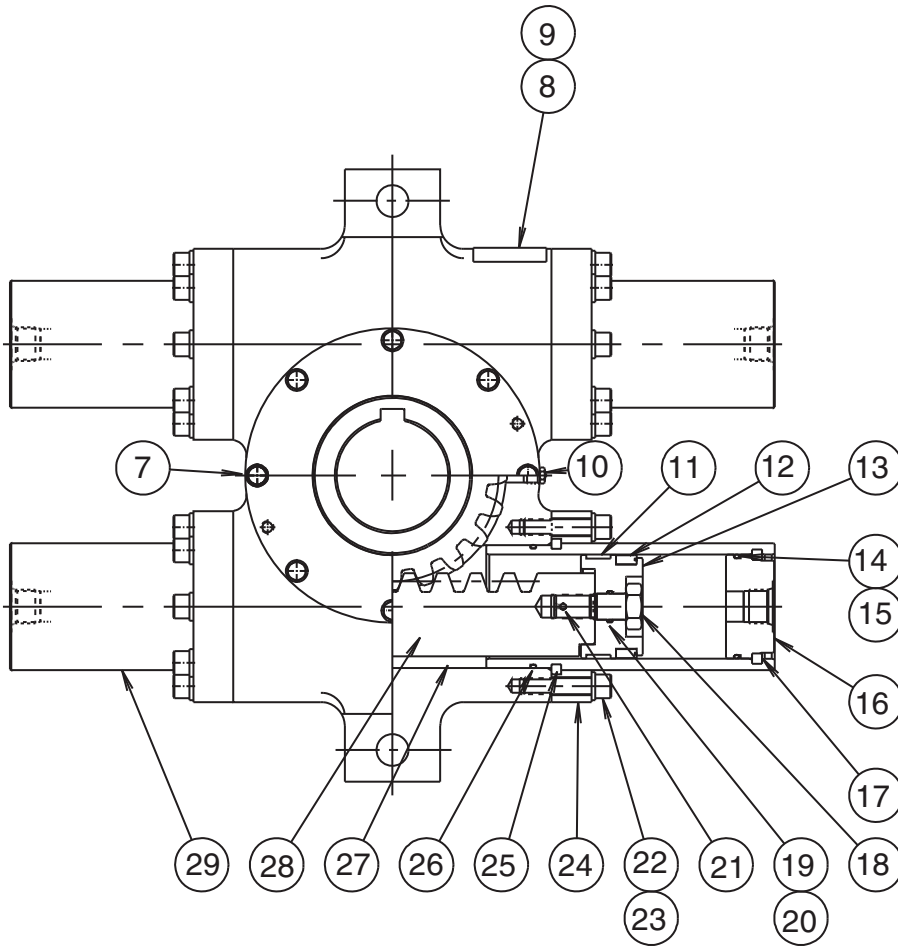

**Cushion Detail**

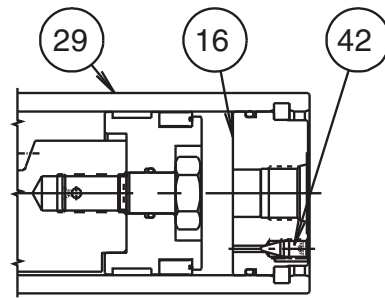

**Air Bleed Detail**

**Torque Table (LB-FT)**

Model No.	Rack Bolt #24 Cush. Plug #35	Bearing Cap Bolt #3	Keeper Flange Bolt #33
15/30M	35	5	10
75/150M	35	18	45
300/600M	110	45	80
1000M	200	90	90

**Notes**

---

## Tork-Mor Standard Series Actuators

# Maintenance Instructions & Parts List

*Provide Model Number and Serial Number When Ordering Spare Parts.*

*The vane and stator should **NEVER** be used for a positive stop. See below Section #1 STOPS.*

Tork-Mor Series actuators have been carefully designed to provide long, trouble-free life given that the unit has been correctly installed and operated within specifications.

The following lists factors relevant to service life and should be read before actuator installation.

### 1. STOPS

The vane and stator should never be used as a positive stop. For light to medium loads a taper lock stop (TLS) option is available. Alternately, external stops mounted securely to machine framework are recommended. For high inertia or high speed loads, externally mounted valving should be used to minimize system shocks.

### 2. SURGE PRESSURES

Surge or shock pressure in excess of the actuator rated pressure are detrimental to unit life and must be avoided. Crossover relief valves mounted adjacent to the actuator can help reduce these abnormal pressure peaks.

### 3. ANGULAR VELOCITY

Angular velocity can be controlled by metering the flow into or out of the actuator ports. This is best accomplished by the use of flow control valves. The actuators are fitted with standard port sizes to provide optimum operating speeds with reasonable pressure drops.

### 4. DRAINS

The actuators are fitted with drain ports to minimize external leakage possibilities. These drain ports should be connected directly back to the oil reservoir with a minimum of back pressure.

### 5. THRUST LOADS

External thrust bearings are required for actuators subjected to axial or thrust loads. These bearings are also recommended where large actuators are mounted in the vertical plane since for all practical purposes the shaft assembly is floating on the seals and can lead to accelerated seal wear.

### 6. RADIAL LOADS

Tork-Mor Series actuators are fitted with ball or roller bearings to support the shaft assembly, but they should not be subjected to external loads. External bearings should be used to support overhung or radial loads.

Supplementary Data

### FLUID MEDIUM

For hydraulic usage a clean, filtered, mineral based oil with 150 to 400 SUS viscosity at 100°F is recommended for use with standard Buna seals. The correct filters can be provided by your Parker Distributor.

Air service units, including filter, regulator and lubricator will ensure correctly conditioned compressed air is available for pneumatically operated systems.

### VANE POSITION

The vane is always positioned on the centerline of the keys with an "0" marking on the shaft end in line with a single vane.

### ACTUATOR SIZE

Selection of the correct actuator is achieved by determining the available system pressure then selecting a unit with 20% to 50% reserve capacity of the application load requirements.

### SEALS

Standard seal compound is nitrile for mineral based hydraulic fluid. Other seal materials can be provided for most operating fluids. To ensure correct seal compound please provide name and type of operating fluid.

### SHAFT COUPLINGS

Couplings should engage the full length of shaft keyway and should only be pressed on after support has been provided on the opposite end of the shaft.

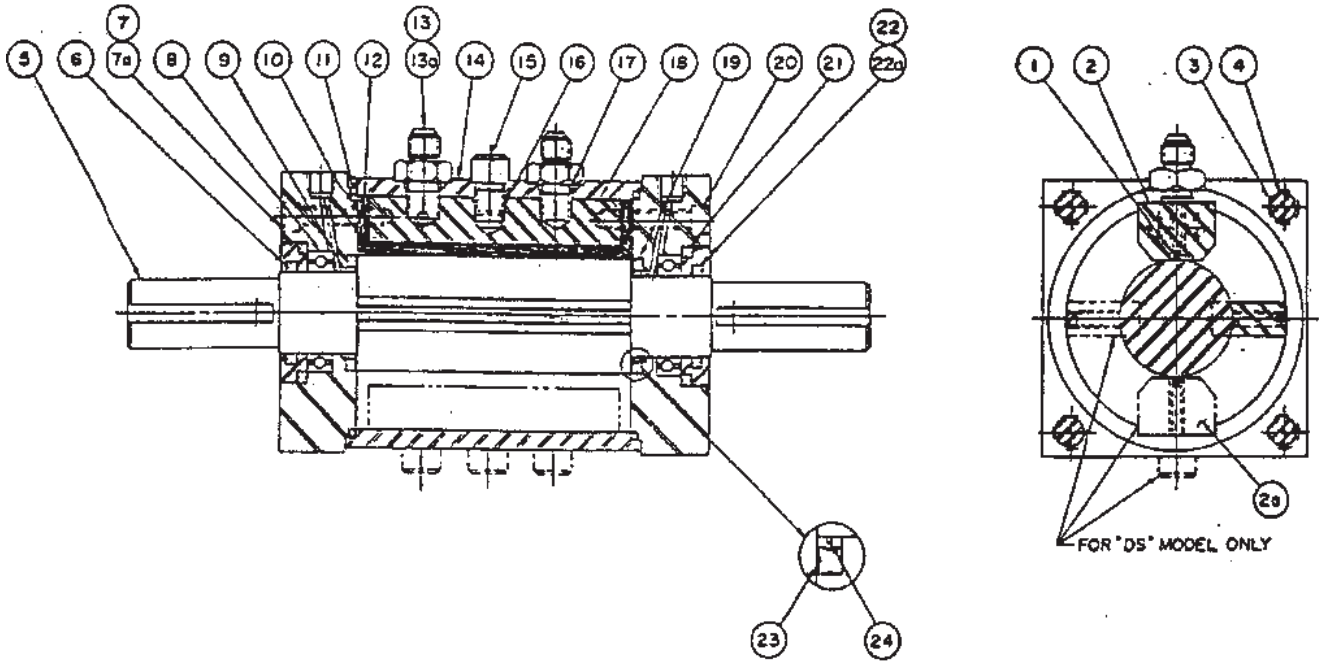

Item No.	Description	S33	DS33	S42	DS42	S44	DS44	S46	DS46	S74	DS74	S77	DS77	S105	DS105	S108	DS108	S112	DS112
● 1	PTFE Backup	4	8	4	8	4	8	4	8	4	8	4	8	4	8	4	8	4	8
2	Stator, Standard	1	1	1	1	1	1	1	1	1	1	1	1	1	1	1	1	1	1
2a	Stator, Dummy	—	1	—	1	—	1	—	1	—	1	—	1	—	1	—	1	—	1
3	Allen Nut	—	—	—	—	4	4	4	4	4	4	4	4	4	4	4	4	4	4
4	Tie Rod	4	4	4	4	4	4	4	4	4	4	4	4	4	4	4	4	4	4
5	Shaft Assembly	1	1	1	1	1	1	1	1	1	1	1	1	1	1	1	1	1	1
● 6	Seal, Retainer Nut Inner	2	2	2	2	2	2	2	2	1	1	1	1	1	1	1	1	1	1
7	Head, Threaded	1	1	1	1	1	1	1	1	1	1	1	1	1	1	1	1	1	1
7a	Head, C'bored	1	1	1	1	1	1	1	1	1	1	1	1	1	1	1	1	1	1
8	Bearing	2	2	2	2	2	2	2	2	2	2	2	2	2	2	2	2	2	2
9	Thrust Bearing	2	2	2	2	2	2	2	2	2	2	2	2	2	2	2	2	2	2
● 10	Seal, Stator	4	4	4	4	4	4	4	4	4	4	4	4	4	10	5	12	7	14
● 11	Seal, Head	2	2	2	2	2	2	2	2	2	2	2	2	2	2	2	2	2	2
● 12	"U" Seal	2	4	2	4	2	4	2	4	2	4	2	4	2	4	2	4	2	4
13	Male Connector	2	2	2	2	2	2	2	2	2	2	2	2	2	2	2	2	2	2
13a	Female Conector	See Note 2																	
14	Body	1	1	1	1	1	1	1	1	1	1	1	1	1	1	1	1	1	1
15	Bolt, Stator	1	2	—	2	1	4	3	6	—	2	1	4	—	2	1	4	3	6
● 16	Seal, Stator Bolt	1	2	—	2	1	4	3	6	—	2	1	4	—	2	1	4	3	6
17	Seal, Connector	2	2	2	2	2	2	2	2	2	2	2	2	2	2	2	2	2	2
18	Gasket	1	2	1	2	1	2	1	2	1	2	1	2	1	2	1	2	1	2
● 19	Seal, Shaft	2	2	2	2	2	2	2	2	2	2	2	2	2	2	2	2	2	2
20	Socket Head Cap Screw	4	4	4	4	4	4	4	4	4	4	4	4	4	8	4	8	4	8
● 21	Seal, Retainer Nut Outer	2	2	2	2	2	2	2	2	2	2	2	2	2	2	2	2	2	2
22	Retainer Nut, Standard <sup>1</sup>	2	2	2	2	2	2	2	2	1	1	1	1	1	1	1	1	1	1
22a	Retainer Nut, Solid <sup>1</sup>	—	—	—	—	—	—	—	—	1	1	1	1	1	1	1	1	1	1
23	Shaft, PTFE Glass Filled	—	—	—	—	—	—	—	—	2	2	2	2	2	2	2	2	2	2
● 24	Seal Thrust Bearing	—	—	—	—	—	—	—	—	2	2	2	2	2	2	2	2	2	2

● Recommended spare parts (seals)  
 1 On single end shaft units, (1) of Item #22 and (1) of Item #22a.  
 2 On units with female connector, quantity for Item #13a is (2).



**GENERAL**

Tork-Mor Actuators, if properly installed, will give many thousand cycles of uninterrupted service. In due time the seals should be replaced and, if correctly installed, new actuator performance will be obtained. We recommend that Tork-Mor Actuators be returned to the factory for repairs. The cost is low and one-day service is our policy. Our trained personnel will see to it that “new actuator” performance is obtained.

In the event that field maintenance is required, the following steps outlined should be followed.

**A. DISASSEMBLY AND INSPECTION OF ACTUATOR**

1. Remove Bearing Retainer Nuts (#22) from Heads (#7).
2. Remove Tie Rods (#4) from Heads (#7).
3. Remove Socket Head Screws (#20) from Heads (#7).
4. Remove Heads (#7) from Body (#14).
5. Remove Shaft (#5) from Body (#14).
6. Remove Ball Bearings (#8) from Heads (#7).
7. Remove Stator Bolts (#15) from Body (#14) and Connector Fittings (#13). On OS models also remove Stator Bolts (#15) from bottom of unit.
8. Remove all seals and clean all parts.

**B. REPLACEMENT OF SEALS AND RE-ASSEMBLY OF ACTUATOR**

*It is recommended that a suitable oil or O-ring lube be used on all seals and mating parts to facilitate assembly.*

1. Install U-Seal (#12) and **PTFE** Back-Ups (#1) in Stator(s) (#2).
2. Replace Stator(s) (#2) with Gasket (#18) and Stator Bolt Seal(s) (#16) into Body (#14).
3. Replace Stator Bolt (#15) and Connectors (#13) with Seals (#17) but **DO NOT** tighten. (Stator bolts are not used on S-4-2 models.)

4. Install Head Seals (#11) Shaft Seals (#19) and Stator Seals (#10) in Heads (#7). On S-7, S-10, DS-7 and DS-10 series models, install Shaft PTFE (#23) on top of Shaft Seals (#19). On S-7 and S-10 series models, also install Thrust Bearing Seals (#24).
5. Place Body (#14) onto one Head (#17). Press lightly until body snaps into place. On DS models, install heads after shaft assembly is in place.
6. Replace Socket Head Screws (#20) in Head (#7) but **DO NOT** tighten.
7. Install U-Seal (#12) and PTFE Back-Ups (#1) into Shaft (#5).
8. Replace Shaft (#5) in Body (#14) and Head (#7). Vane should be located opposite Stator (#2).
9. Replace other Head (#7) into Body (#14). Press lightly until head snaps into place.
10. Replace Socket Head Screws (#20) in Head (#7) but **DO NOT** tighten.
11. Replace Tie Rods (#4) and tighten evenly.
12. Tighten Stator Bolt(s) (#15) and Socket Head Screws (#20).
13. Replace Bearings (#8) into Heads (#7). At this point the actuator may be pressurized to check Head Seals (#11) and Shaft Seals (#19) for leakage.
14. Install Outer Seals (#6) into Retaining Nuts (#22).
15. Install Inner Seals (#6) into Retaining Nuts (#22).
16. Screw Retainer Nuts (#22), into Heads (#7).

Additional information may be obtained from Pneumatic Division, Wadsworth, Ohio or from the nearest Pneumatic Division Representative.

**Tightening Torques**

MODEL SIZE	TIE ROD BOLT (#4)
33	13 ft. lbs.
42	25 ft. lbs.
44	25 ft. lbs.
46	25 ft. lbs.
74	130 ft. lbs.
77	130 ft. lbs.
105	500 ft. lbs.
108	500 ft. lbs.
1012	500 ft. lbs.

**Notes**

---

**Notes**

---

**Notes**

---

**Notes**

---

## Offer of Sale

---

The items described in this document and other documents or descriptions provided by Parker Hannifin Corporation, its subsidiaries and its authorized distributors are hereby offered for sale at prices to be established by Parker Hannifin Corporation, its subsidiaries and its authorized distributors. This offer and its acceptance by any customer ("Buyer") shall be governed by all of the following Terms and Conditions. Buyer's order for any such item, when communicated to Parker Hannifin Corporation, its subsidiary or an authorized distributor ("Seller") verbally or in writing, shall constitute acceptance of this offer.

**1. Terms and Conditions of Sale:** All descriptions, quotations, proposals, offers, acknowledgments, acceptances and sales of Seller's products are subject to and shall be governed exclusively by the terms and conditions stated herein. Buyer's acceptance of any offer to sell is limited to these terms and conditions. Any terms or conditions in addition to, or inconsistent with those stated herein, proposed by Buyer in any acceptance of an offer by Seller, are hereby objected to. No such additional, different or inconsistent terms and conditions shall become part of the contract between, Buyer and Seller unless expressly accepted in writing by Seller. Seller's acceptance of any offer to purchase by Buyer is expressly conditional upon Buyer's assent to all the terms and conditions stated herein, including any terms in addition to, or inconsistent with those contained in Buyer's offer. Acceptance of Seller's products shall in all events constitute such assent.

**2. Payment:** Payment shall be made by Buyer net 30 days from the date of delivery of the items purchased hereunder. Amounts not timely paid shall bear interest at the maximum rate permitted by law for each month or portion thereof that the Buyer is late in making payment. Any claims by Buyer for omissions or shortages in a shipment shall be waived unless Seller receives notice thereof within 30 days after Buyer's receipt of the shipment.

**3. Delivery:** Unless otherwise provided on the face hereof, delivery shall be made F.O.B. Seller's plant. Regardless of the method of delivery, however, risk of loss shall pass to Buyer upon Seller's delivery to a carrier. Any delivery dates shown are approximate only and Seller shall have no liability for any delays in delivery.

**4. Warranty:** Seller warrants that the items sold hereunder shall be free from defects in material or workmanship for a period of 18 months from date of shipment from Parker Hannifin Corporation. **THIS WARRANTY COMPRISES THE SOLE AND ENTIRE WARRANTY PERTAINING TO ITEMS PROVIDED HEREUNDER. SELLER MAKES NO OTHER WARRANTY, GUARANTEE, OR REPRESENTATION OF ANY KIND WHATSOEVER. ALL OTHER WARRANTIES, INCLUDING BUT NOT LIMITED TO, MERCHANTABILITY AND FITNESS FOR PURPOSE, WHETHER EXPRESS, IMPLIED, OR ARISING BY OPERATION OF LAW, TRADE USAGE, OR COURSE OF DEALING ARE HEREBY DISCLAIMED.**

**NOTWITHSTANDING THE FOREGOING, THERE ARE NO WARRANTIES WHATSOEVER ON ITEMS BUILT OR ACQUIRED WHOLLY OR PARTIALLY, TO BUYER'S DESIGNS OR SPECIFICATIONS.**

**5. Limitation of Remedy:** SELLER'S LIABILITY ARISING FROM OR IN ANY WAY CONNECTED WITH THE ITEMS SOLD OR THIS CONTRACT SHALL BE LIMITED EXCLUSIVELY TO REPAIR OR REPLACEMENT OF THE ITEMS SOLD OR REFUND OF THE PURCHASE PRICE PAID BY BUYER, AT SELLER'S SOLE OPTION. IN NO EVENT SHALL SELLER BE LIABLE FOR ANY INCIDENTAL, CONSEQUENTIAL OR SPECIAL DAMAGES OF ANY KIND OR NATURE WHATSOEVER, INCLUDING BUT NOT LIMITED TO LOST PROFITS ARISING FROM OR IN ANY WAY CONNECTED WITH THIS AGREEMENT OR ITEMS SOLD HEREUNDER, WHETHER ALLEGED TO ARISE FROM BREACH OF CONTRACT, EXPRESS OR IMPLIED WARRANTY, OR IN TORT, INCLUDING WITHOUT LIMITATION, NEGLIGENCE, FAILURE TO WARN OR STRICT LIABILITY.

**6. Changes, Reschedules and Cancellations:** Buyers may request to modify the designs or specifications for the items sold hereunder as well as the quantities and delivery dates thereof, or may request to cancel all or part of this order, however, no such requested modification or cancellation shall become part of the contract between Buyer and Seller unless accepted by Seller in a written amendment to this Agreement. Acceptance of any such requested modification of cancellation shall be at Seller's discretion, and shall be upon such terms and conditions as Seller may require.

**7. Special Tooling:** A tooling charge may be imposed for any special tooling, including without limitation, dies, fixtures, molds and patterns, acquired to manufacture items sold pursuant to this contract. Such special tooling shall be and remain Seller's property notwithstanding payment of any charges by Buyer. In no event will Buyer acquire any interest in apparatus belonging to Seller which is utilized in the manufacture of the items sold hereunder, even if such apparatus has been specially converted or adapted for such manufacture and notwithstanding any charges paid by Buyer. Unless otherwise agreed, Seller shall have the right to alter, discard or otherwise dispose of any special tooling or other property in its sole discretion at any time.

**8. Buyer's Property:** Any designs, tools, patterns, materials, drawings confidential information or equipment furnished by Buyer, or any other items which become Buyer's property, may be considered obsolete and may be destroyed by Seller after two (2) consecutive years have elapsed without Buyer placing an order for the items which are manufactured using such property. Seller shall not be responsible for any loss or damage to such property while it is in Seller's possession or control.

**9. Taxes:** Unless otherwise indicated on the face hereof, all prices and charges are exclusive of excise, sales, use, property, occupational or like taxes which may be imposed by any taxing authority upon the manufacture, sale or delivery of the items sold hereunder. If any such taxes must be paid by Seller or if Seller is liable for the collection of such tax, the amount thereof shall be in addition to the amounts for the items sold. Buyer agrees to pay all such taxes or to reimburse Seller therefore upon receipt of its invoice. If Buyer claims exemption from any sales, use or other tax imposed by any taxing authority, Buyer shall save Seller harmless from and against any such tax, together with any interest or penalties thereon which may be assessed if the items are held to be taxable.

**10. Indemnity For Infringement of Intellectual Property Rights:** Seller shall have no liability for infringement of any patents, trademarks, copyrights, trade dress, trade secrets or similar rights except as provided in this Part 10. Seller will defend and indemnify Buyer against allegations of infringement of U.S. patents, U.S. trademarks, copyrights, trade dress and trade secrets (hereinafter 'Intellectual Property Rights'). Seller will defend at its expense and will pay the cost of any settlement or damages awarded in an action brought against Buyer based on an allegation that an item sold pursuant to this contract infringes the Intellectual Property Rights of a third party. Seller's obligation to defend and indemnify Buyer is contingent on Buyer notifying Seller within ten (10) days after Buyer becomes aware of such allegations of infringement, and Seller having sole control over the defense of any allegations or actions including all negotiations for settlement or compromise. If an item sold hereunder is subject to a claim that it infringes the Intellectual Property Rights of a third party, Seller may, at its sole expense and option, procure for Buyer the right to continue using said item, replace or modify said item so as to make it noninfringing, or offer to accept return of said item and return the purchase price less a reasonable allowance for depreciation. Notwithstanding the foregoing, Seller shall have no liability for claims of infringement based on information provided by Buyer, or directed to items delivered hereunder for which the designs are specified in whole or part by Buyer, or infringements resulting from the modification, combination or use in a system of any item sold hereunder. The foregoing provisions of this Part 10 shall constitute Seller's sole and exclusive liability and Buyer's sole and exclusive remedy for infringement of Intellectual Property Right.

If a claim is based on information provided by Buyer or if the design for an item delivered hereunder is specified in whole or in part by Buyer, Buyer shall defend and indemnify Seller for all costs, expenses or judgements resulting from any claim that such item infringes any patent, trademark, copyright, trade dress, trade secret or any similar right.

**11. Force Majeure:** Seller does not assume the risk of and shall not be liable for delay or failure to perform any of Seller's obligations by reason of circumstances beyond the reasonable control of Seller (hereinafter 'Events of Force Majeure'). Events of Force Majeure shall include without limitation, accidents, acts of God, strikes or labor disputes, acts, laws, rules or regulations of any government or government agency, fires, floods, delays or failures in delivery of carriers or suppliers, shortages of materials and any other cause beyond Seller's control.

**12. Entire Agreement/Governing Law:** The terms and conditions set forth herein, together with any amendments, modifications and any different terms or conditions expressly accepted by Seller in writing, shall constitute the entire Agreement concerning the items sold, and there are no oral or other representations or agreements which pertain thereto. This Agreement shall be governed in all respects by the law of the State of Ohio. No actions arising out of the sale of the items sold hereunder of this Agreement may be brought by either party more than two (2) years after the cause of action accrues.



**Parker Hannifin Corporation**  
Pneumatic Division  
135 Quadral Drive  
Wadsworth, OH 44281 USA  
Phone: 330 336 3511  
Fax: 330 334 3335  
Web site: [www.parker.com/pneumatic](http://www.parker.com/pneumatic)  
e-mail: [pdnmktg@parker.com](mailto:pdnmktg@parker.com)