



**Hydroven**<sup>®</sup>  
*Hydraulic Energy*

**MINICENTRALINE** MINI POWER P ACKS





Indice Index	Esempi di applicazioni Some applications	2
	Minicentralina multifunzione Multifunction power pack	4
	Minicentralina multifunzione "compatta" Multifunction power pack "compact"	5
	Motori elettrici Electric motors	6
	Elementi di connessione Connection elements	8
	Corpo centrale di collegamento Connecting central housing	10
	Corpo centrale di collegamento versione HA Connecting central housing HA version	12
	Pompe oleodinamiche Hydraulic pumps	13
	Gruppo con pompa doppia Group double gear pump	14
	Filtri in aspirazione Suction filters	15
	Serbatoi olio per minicentraline Mini power pack's steel oil tank	16
	Tappi serbatoi olio per minicentraline Mini power pack's oil cap	23
	Collare per serbatoio Oil tanks flange	23
	Serbatoi olio in plastica per minicentraline Mini power pack's plastic oil tank	24
	Supporto montaggio centralina Mounting support for power pack	26
	Valvole a cartuccia Cartridge valve	27
	Strozzatore compensato fisso Compensated throttle	29
	Piastre modulari Modular plates	30
	Valvole CETOP-3 CETOP-3 valves	32
	Pompa a mano Hand pump	33
	Elettrovalvole CETOP-3 Solenoid valves CETOP-3	34
	Connettori per elettrovalvole Solenoid valves connectors	34
	Schema e tipologia elettrovalvole Solenoid valves type and scheme	35
	Piastre modulari Modular plates	36
	Valvole a comando manual CETOP-3 CETOP-3 manual control valves	37
	Elementi applicabili Applicable elements	38
	Manometro ad attacco radiale Radial connection pressure gauge	39
	Manometro ad attacco posteriore Posterior connection pressure gauge	39
	Kit radiocomando per veicoli industriali Radiocontrol kit for industrial vehicles	40

BLOCCAGGIO PER MACCHINE UTENSILI

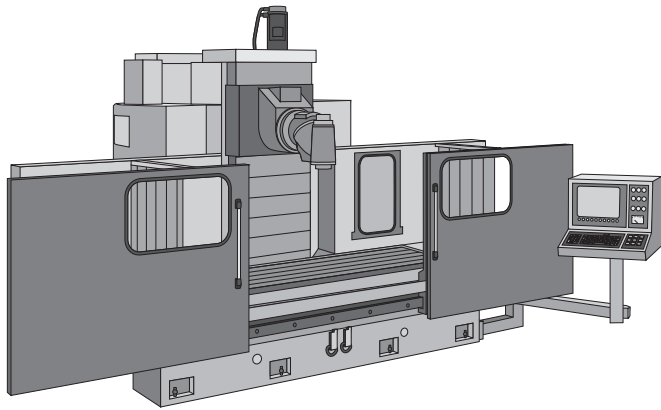

MOTOSCOPE



CARRELLI ELEVATORI

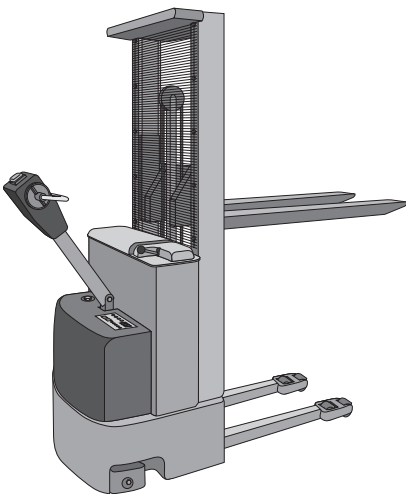

**ESEMPI DI APPLICAZIONI.** L'unità di potenza HV/UI è un prodotto estremamente versatile, composta da elementi modulari di dimensioni ridotte e da una vasta gamma di particolari dall'estrema semplicità di assemblaggio, garantisce e permette la soluzione di molteplici applicazioni in modo compatto e senza necessità di tubi ed assemblaggi supplementari.

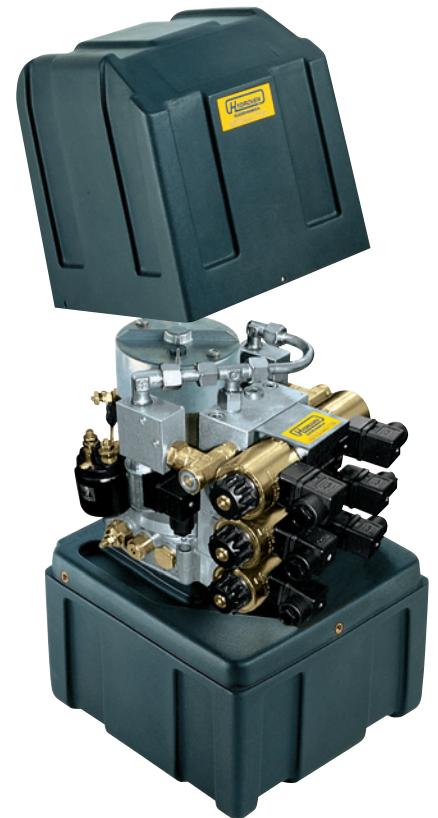

PEDANE MOBILI DI CARICO

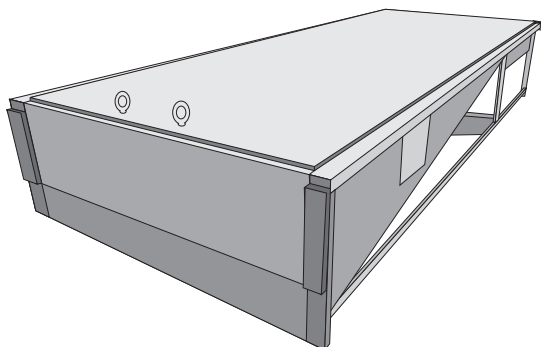

SMONTAGOMME

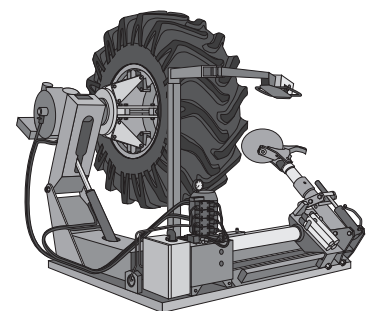

SPONDE MOBILI PER VEICOLI

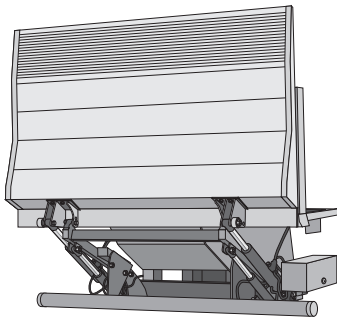

PIATTAFORME DI SOLLEVAMENTO

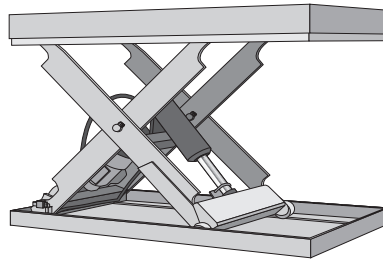

CARRELLI SVOLGICAVO

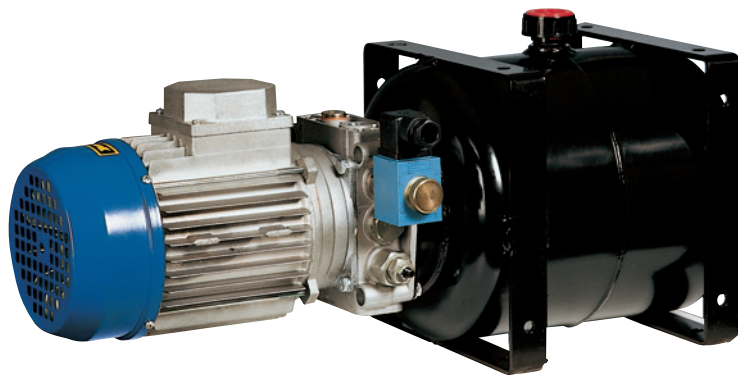
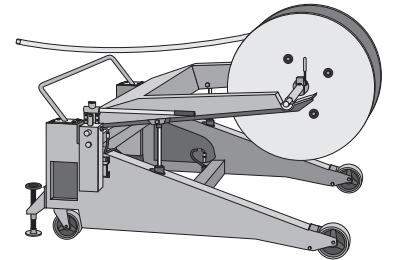

**SOME APPLICATIONS.** HV/UI power unit is an extremely versatile product composed of modular elements with smaller dimensions and a large range of simple assembling parts. It guarantees and permits solution of a lot of applications in a compact way without any necessity of tubes and supplements assembling.

PIATTAFORME DI SOLLEVAMENTO

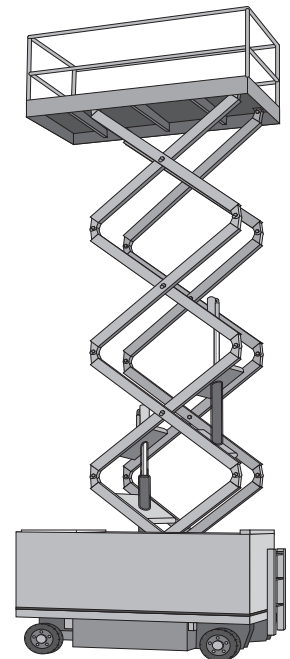

PIATTAFORME DI SOLLEVAMENTO



CARRELLI ELEVATORI



# MINICENTRALINA MULTIFUNZIONE      MULTIFUNCTION POWER PACK

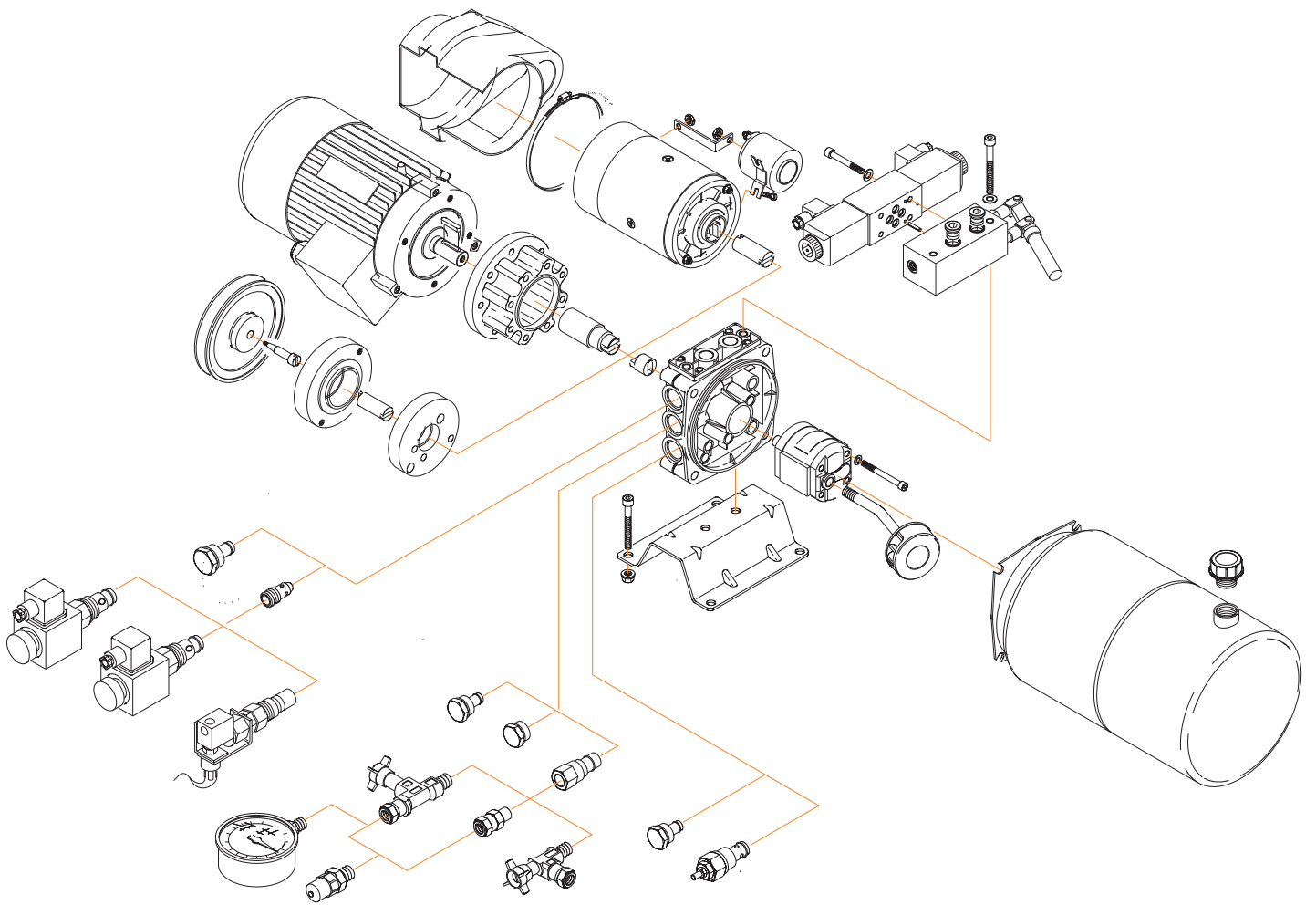

MINICENTRALINA MULTIFUNZIONE "COMPATTA"

MULTIFUNCTION POWER PACK "COMPACT"

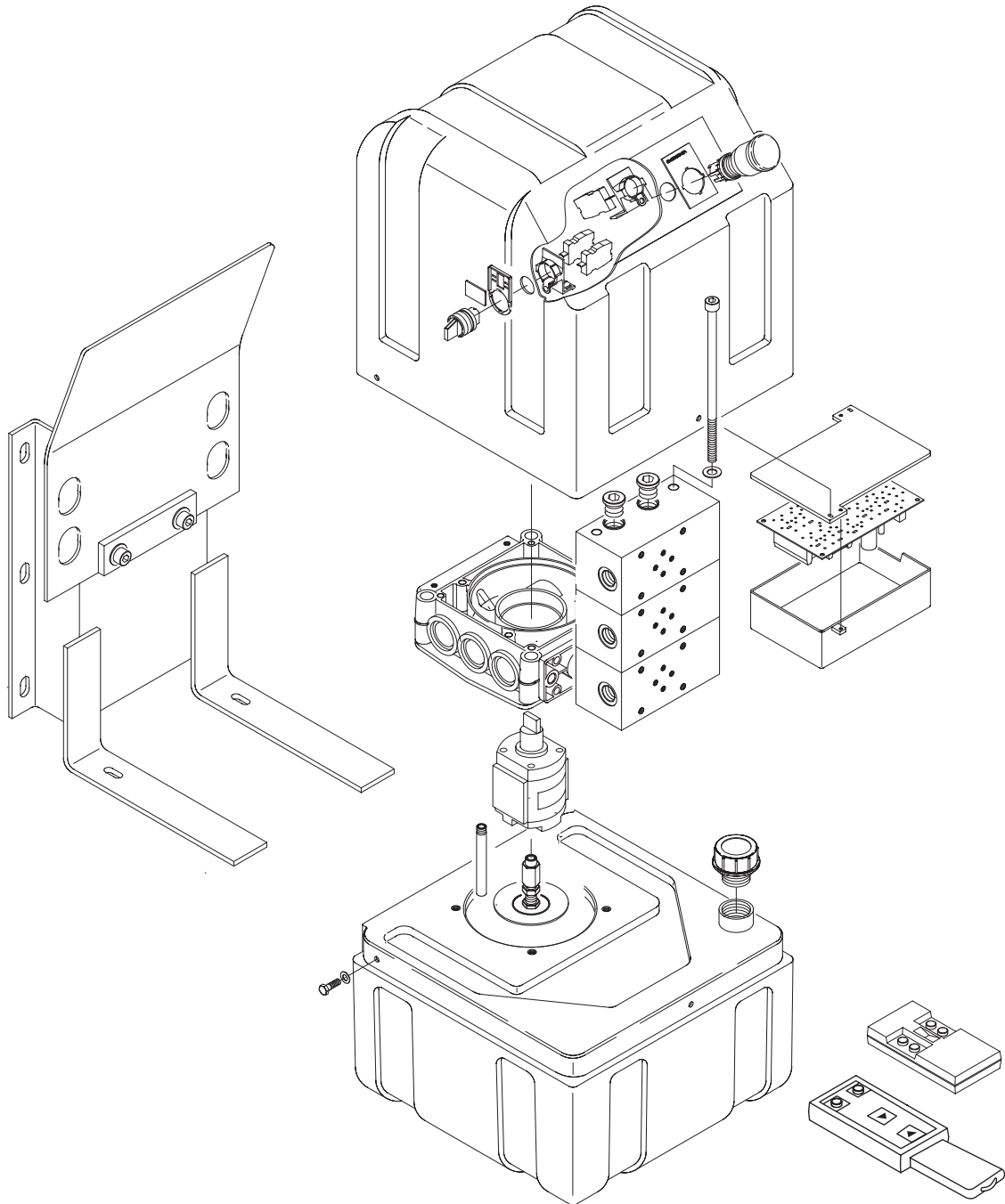

## MOTORI ELETTRICI ELECTRIC MOTORS

Codice Code	Descrizione Description	L (mm)	D (mm)
<b>Motori corrente continua con termocoppia e teleruttore</b> Direct current motors with thermocouple and start relay			
56250A180L0H	Motore Motor 12V 1800W*	190	160
56250B200L0H	Motore Motor 24V 2000W*		
56250A160L2K	Motore Motor AMJ-5197 12V 1,6KW		
56250B220L2K	Motore Motor AMJ-5196 24V 2,2KW		

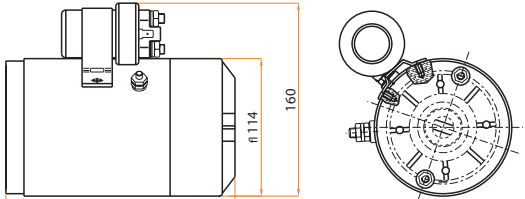

<b>Motori corrente continua ventilato e termocoppia</b> Fan D.C. motor and thermocouple			
56250A150M4F	Motore Motor 12V 1500W D.113 B14-71	235	129
4252BA200A2C	Motore Motor 12V 2000W D.113 B14-71		
56250B200M4F	Motore Motor 24V 2000W D.113 B14-71	264 ±1.5	130.5
56250B300R2K	Motore Motor AMK-5513 24V 3KW		
4252BA250B2C	Motore Motor 12V 2500W D.125 B14/71		
4252BB250B2C	Motore Motor 24V 2500W D.125 B14/71		

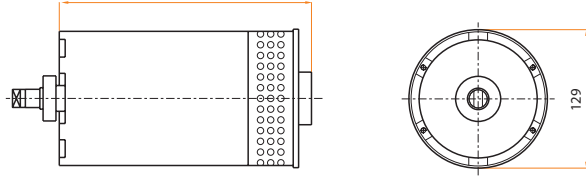
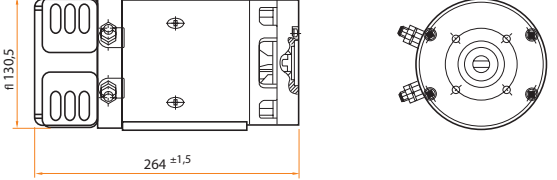
<b>Motori corrente continua senza teleruttore</b> Direct current motors without start relay			
56150A050E2K	Motore Motor AME-1726 12V 0,5 KW	152.5	89.5
56150B050E0K	Motore Motor AME-1557 24V 0,5KW		
56150A080F1K	Motore Motor AME-1707 12V 0,8KW		
56150B080F1K	Motore Motor AME-1709 24V 0,8KW		

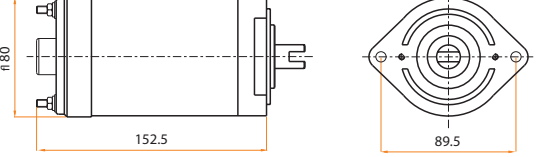

<b>Motori corrente continua ventilato senza termocoppia</b> Direct current fan motors without thermocouple			
56250A150L5K	Motore Motor AMJ-5143 12V 1,5KW	MAX. 211,5	8e10 90±0,2
56250B220L5K	Motore Motor AMJ-5233 24V 2KW		
425Z0ST2422K	Kit Termocoppia per motore Motor thermocouple kit 12V-24V		

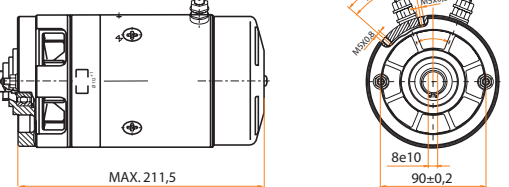

<b>Teleruttore di avviamento</b> Starting relay				L	D
56252120800K	Teleruttore Relay 12V 80A ARD1133	86	52	L	D
56252121500K	Teleruttore Relay 12V 150A RINF. ARD1139	100	52		
56252240800K	Teleruttore Relay 24V 80A ARD1134	86	52		
56252241500K	Teleruttore Relay 24V 150A RINF. ARD1138	100	52		
56252243000K	Teleruttore Relay 24V 300A RINF. ARD1308	112,5	61		

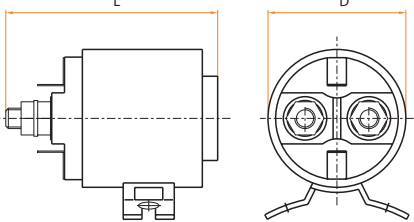



**MOTORI ELETTRICI ELECTRIC MOTORS**

Codice Code	Descrizione Description	A (mm)	B (mm)	C (mm)
<b>Coperchio motore Protection cover for motor</b>				
56253010000H	Cuffia Cover UPE-9	189	164	
56253010000N	Cuffia Cover UPE-10 *	204	180	118

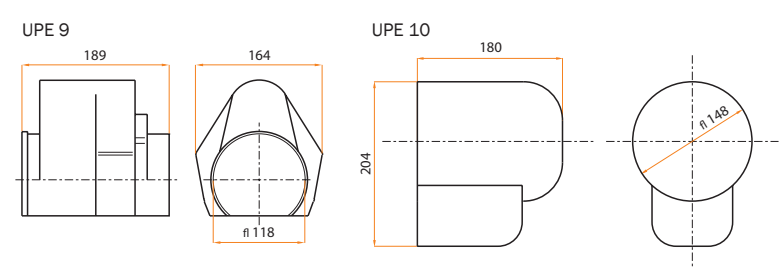

\* Solo per motore / Only for motor 12V 1800W - 24V 2000W

**Motori corrente alternata trifasi A.C. threephase motors 230-400 VOLT 50 Hz B14 2 POLI**

42303210B11_	Motore Motor KW 0,37 B14 2p.230/400V 50Hz	219	137	108
42303210B21_	Motore Motor KW 0,55 B14 2p. 230/400V 50Hz	219	137	108
42303210C11_	Motore Motor KW 0,75 B14 2p. 230/400V 50Hz	233	156	122
42303210C21_	Motore Motor KW 1 B14 2p.230/400V 50Hz	233	156	122
42303210D11_	Motore Motor KW 1,5 B14 2p. 230/400V 50Hz	252	176	129
42303210D21_	Motore Motor KW 2,2 B14 2p. 230/400V 50Hz	276	176	129
42303210E11_	Motore Motor KW 3 B14 2p. 230/400V 50Hz	306	195	140
42303210F11_	Motore Motor KW 4 B14 2p 230/400V 50Hz	325	220	160

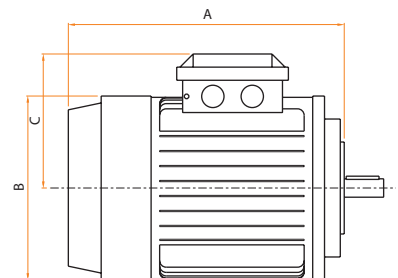
**Motori corrente alternata trifasi A.C. threephase motors 230-400 VOLT 50 Hz B14 4 POLI**

42303410B11_	Motore Motor KW0,25 B14 4p. 230/400V 50Hz	219	137	108
42303410B21_	Motore Motor KW0,37 B14 4p.230/400V 50Hz	219	137	108
42303410C11_	Motore Motor KW0,55 B14 4p. 230/400V 50Hz	233	156	122
42303410C21_	Motore Motor KW0,75 B14 4p. 230/400V 50Hz	233	156	122
42303410D11_	Motore Motor KW 1,1 B14 4p. 230/400V 50Hz	252	176	129
42303410D21_	Motore Motor KW1,5 B14 4p. 230/400V 50Hz	276	176	129
42303410E11_	Motore Motor KW2,2 B14 4p. 230/400V 50Hz	306	195	140
42303410E21_	Motore Motor KW 3 B14 4p. 230/400V 50Hz	306	195	140
42303410F11_	Motore Motor KW4 B14 4p. 230/400V 50Hz	325	220	160

**Motori corrente alternata monofasi A.C. singlephase motors 220 VOLT 50 Hz B14 2 POLI**

42203210C21_	Motore Motor KW 0,55 B14 2p. 220V 50Hz	219	137	108
42203210D21_	Motore Motor KW 0,75 B14 2p. 220V 50Hz	233	156	122
42203210F11_	Motore Motor KW 1,1 B14 2p. 220V 50Hz	233	156	122
42203210G11_	Motore Motor KW 1,5 B14 2p. 220V 50Hz	252	176	129
42203210L11_	Motore Motor KW 2,2 B14 2p. 220V 50Hz	276	176	129

**Motori corrente alternata monofasi A.C. singlephase motors 220 VOLT 50 Hz B14 4 POLI**

42203410C11_	Motore Motor KW0,25 B14 4p. 220V 50Hz	219	137	108
42203410D11_	Motore Motor KW 0,37 B14 4p. 220V 50Hz	219	137	108
42203410D21_	Motore Motor KW0,55 B14 4p. 220V 50Hz	233	156	122
42203410E21_	Motore Motor KW0,75 B14 4p. 220V 50Hz	233	156	122
42203410G21_	Motore Motor KW 1,1 B14 4p. 220V 50Hz	252	176	129
42203410G31_	Motore Motor KW1,5 B14 4p. 220V 50Hz	276	176	129

## ELEMENTI DI CONNESSIONE CONNECTION ELEMENTS

Codice Code	Tipo Type	Motore / Motor (Potenza HP)					Dis.
		2 Poli	4 Poli	Gr.	Monofase	Trifase	

Flangia per motore elettrico corrente alternata monofase e trifase  
Flange for A.C. electric motors monophas and threephase

56237070D00Q	FLCA71	0,5	0,35	71	•	•	1
56237070D00Q	FLCA71	0,75	0,5	71	•	•	1
56237080F00Q	FLCA80	1	0,75	80	•	•	2
56237080F00Q	FLCA80	1,5	1	80	•	•	2
56237095H00Q	FLCA90	2	1,5	90	•	•	3
56237095H00Q	FLCA90	3	2	90	•	•	3
56237110K00Q	FLCA100	4	3	100	•	•	4
56237110K00Q	FLCA100		4	100		•	4
56237110K00Q	FLCA100	5,5	5,5	112		•	4

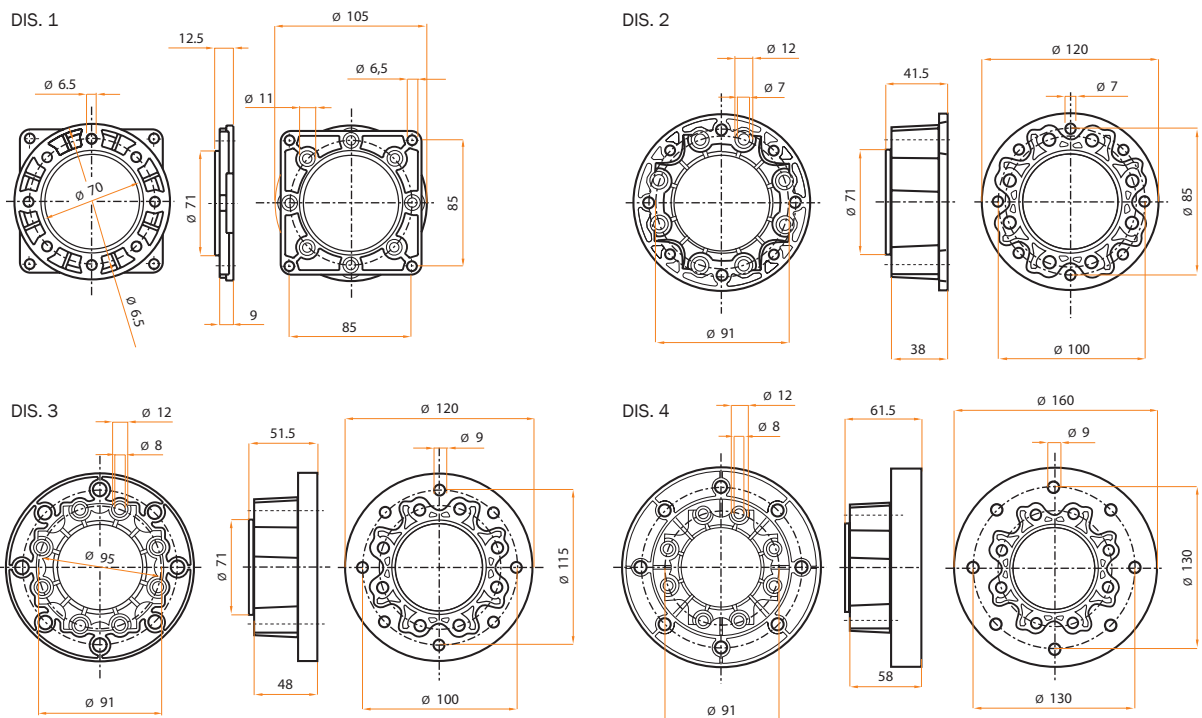

Codice Code	Descrizione Description
-------------	-------------------------

Flangia per motori corrente continua  
Flange for DC electric motors

1201PF00610T	Flangia per motore 3 kW	Flange for motor 3 kW
1201PF00620T	Flangia per motore 0,5-0,8 kW 12-24V	Flange for motor 0,5-0,8 kW 12-24V

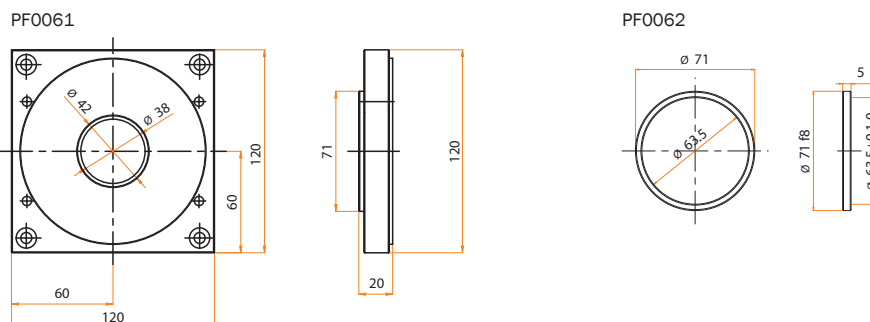

**ELEMENTI DI CONNESSIONE CONNECTION ELEMENTS**

Codice Code	Tipo Type	Motore / Motor (Potenza HP)					Dimensioni / Dimension (mm)					
		2 Poli	4 Poli	Gr.	Monofase	Trifase	A	B	C	D	E	F

Giunto per motore elettrico corrente alternata monofase e trifase (Disegno 1 )  
 Coupling for A.C. electric motors monophase and threephase (Drawing 1)

56241DE50K0T	PG0015	0,5	0,35	71	•	•	35	28	14	6	16.3	5D10
56241DE50K0T	PG0015	0,75	0,5	71	•	•	35	28	14	6	16.3	5D10
56241FF40K0T	PG0016	1	0,75	80	•	•	64	31	19	6.5	21.8	6D10
56241FF40K0T	PG0016	1,5	1	80	•	•	64	31	19	6.5	21.8	6D10
56241HG40K0T	PG0017	2	1,5	90	•	•	74	36	24	6.5	27.3	8D10
56241HG40K0T	PG0017	3	2	90	•	•	74	36	24	6.5	27.3	8D10
56241KH20K0T	PG0018		3	100	•	•	82	40	28	6.5	31.3	8D10
56241KH20K0T	PG0018		4	100		•	82	40	28	6.5	31.3	8D10
56241KH20K0T	PG0018		5,5	112		•	82	40	28	6.5	31.3	8D10

1201PG00330T	PG0033	Giunto ant. Gr.1 Joint ant. Pump Gr.1 ( disegno - drawing 2)									
1201PG00600T	PG0060	Giunto ant. Gr.0 Joint ant. Pump Gr.0									

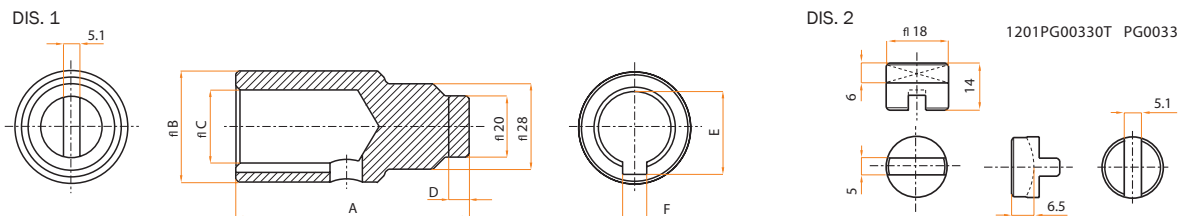

Codice Code	Tipo Type	Caratteristiche Characteristics	Volt	Watt	fl
-------------	-----------	---------------------------------	------	------	----

Giunto per motore elettrico corrente continua  
 Coupling for D.C. electric motors

563422B20EET	PG0003	Giunto	Joint mod. O.S.D. 17,5 L=32	12	1600-1800	114
563422B20EET	PG0003	Giunto	Joint mod. O.S.D. 17,5 L=32	24	2000-2200	114
56241DE50K0T	PG0015	Giunto lato motore	Joint side motor Gr. 1 HP 0,33-0,5	12-24	2500	125
56241FF40K0T	PG0016	Giunto lato motore	Joint side motor Gr.1 HP 0,75-1	12-24	2500	150
1201PG00560T	PG0056	Giunto lato motore	Joint for motor kW 3	24	3000	125
1201PG00570T	PG0057	Giunto lato motore	Joint for motor kW 0,5/0,8 pump Gr. 0	12-24	500 - 800	80
1201PG00590P	PG0059	Giunto lato motore	Joint for motor kW 0,5/0,8 pump Gr. 1	12-24	500 - 800	80

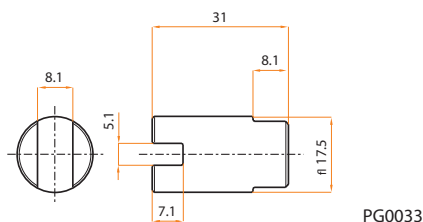

Trascinamenti indipendenti  
 Independent drive systems

56242EP1000T	TI 98	Trascinamento indipendente senza puleggia Independent drive system without pulley
56242EP3000T	TI 99	Trascinamento indipendente con puleggia Independent drive system with pulley
56242FO1000T	TI 100	Puleggia Pulley D = 100 mm.
56242FO1250T	TI 125	Puleggia Pulley D = 125 mm. (Dp 125 - 1)

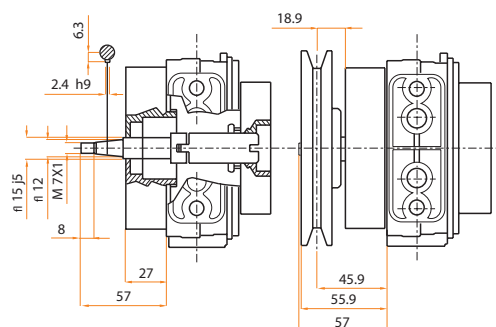

## CORPO CENTRALE DI COLLEGAMENTO      CONNECTING CENTRAL HOUSING

Codice Code	Tipo Type	Descrizione Description
5620121H100P	H1*	Corpo nella versione per circuito a Doppio Effetto, predisposto per attacco piastra applicazione elettrovalvole, provvisto di valvola di max e di ritegno su P. Double acting circuit housing, predisposed for solenoid valves application plate, with max valve and check valve on P.
5620121H200P	H2*	Corpo nella versione per circuito a Doppio Effetto, predisposto per attacco piastra applicazione elettrovalvole, provvisto di valvola di max ma senza valvola di ritegno su P. Double acting circuit housing, predisposed for solenoid valves application plate, with max valve but without check valve on P.
5620121H300P	H3*	Corpo nella versione per circuito a Doppio Effetto, predisposto per attacco piastra applicazione elettrovalvole, provvisto di valvola di ritegno su P ma senza la valvola di max pressione. Double acting circuit housing, predisposed for solenoid valves, with check valve on P but without max pressure valve.
5620121H400P	H4*	Corpo nella versione per circuito a Doppio Effetto, predisposto per attacco piastra applicazione elettrovalvole, senza la valvola di ritegno su P e della valvola di max pressione. Double acting circuit housing, predisposed for solenoid valves, without check valve on P and max pressure valve.

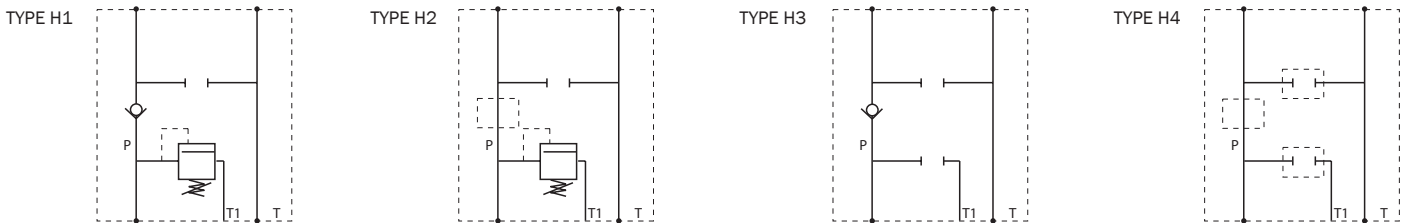

\* Premontato Pre-assembled

Collettore centrale nell'esecuzione a Semplice Effetto (H7) con elettrovalvola di messa a scarico  
Central manifold to execute a single acting (H7) with discharge electric valve

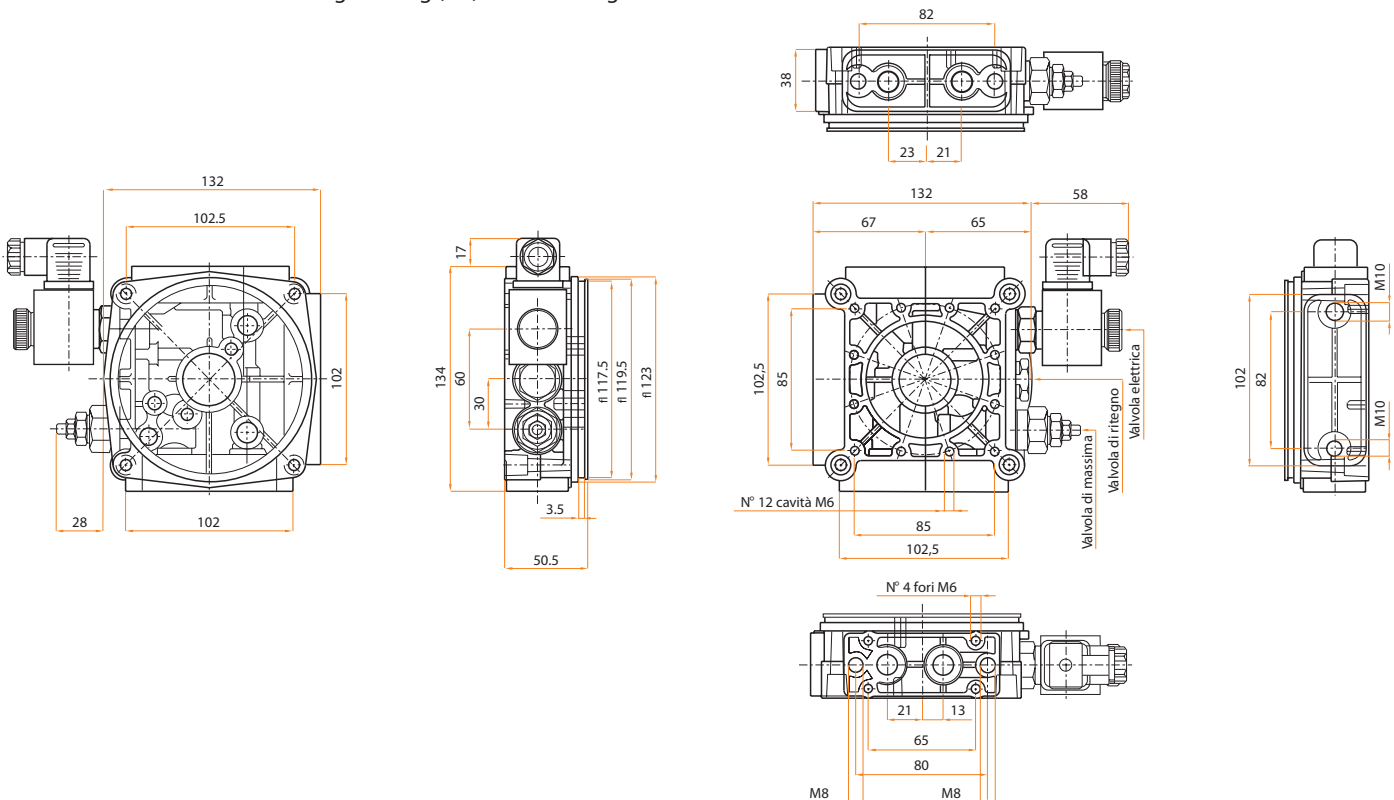

## CORPO CENTRALE DI COLLEGAMENTO      CONNECTING CENTRAL HOUSING

Codice Code	Tipo Type	Descrizione Description
5620121H7**P	H7*	Corpo nella versione per circuito a Semplice Effetto, predisposto per inserimento elettrovalvola di controllo N.C. o N.A., provvisto di valvola di max e di ritegno su P. Single acting version housing, predisposed for normally closed or open solenoid valve. With max pressure valve and check valves on P.
H8		Corpo nella versione per circuito a Semplice Effetto, predisposto per inserimento elettrovalvola di controllo N.C. o N.A. Con strozzatore compensato in scarico, provvisto di valvola di max e di ritegno su P. Single acting version housing, predisposed for normally closed or open solenoid valve. With compensated throttler on outlet with max pressure valve and check valves on P.
H12		Corpo nella versione per circuito a Doppio Effetto, predisposto per attacco piastra applicazione elettrovalvole, completo di pompa doppia ad ingranaggi/pistoni, con valvola disgiuntrice, valvola di max pressione e due ritegni sulle P delle pompe. Double acting circuit housing predisposed for plate application solenoid valves, complete of double gear pump/piston pump, with disjoin valve, max pressure valve and two check devices on P of the pumps.

- \* Premontato Pre-assembled  
 \*\* Specificare tensione bobina in fase di ordine  
 Solenoid voltage robe specified

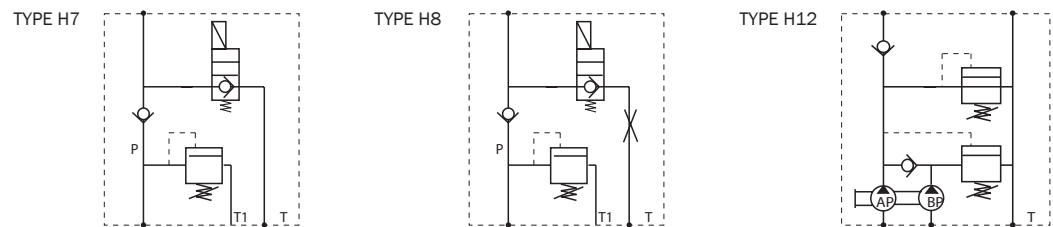

Soluzioni di valvole applicate internamente al blocco centrale  
 Solution of internal application valves to the central block

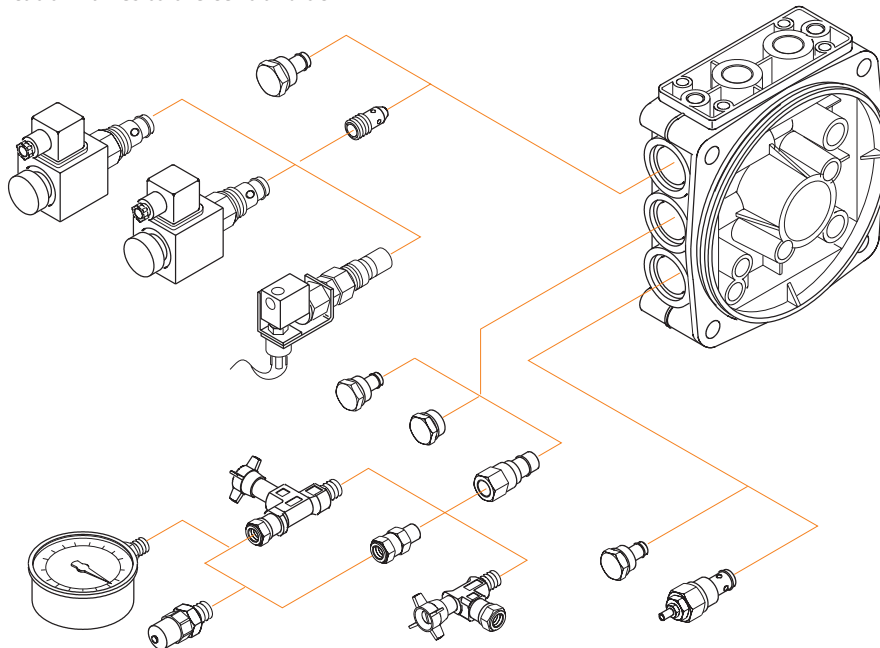

Codice Code	Descrizione Description	Taratura Pressure range
56203P31600V	VA LV. MAX PRESS. CP20-U Molla bianca White spring	5 ÷ 60 bar
56203P31700V	VA LV. MAX PRESS. CP20-U Molla gialla Yellow spring	20 ÷ 130 bar
56203P31800V	VA LV. MAX PRESS. CP20-U Molla verde Green spring	40 ÷ 240 bar
56203P31900V	VA LV. MAX PRESS. CP20-U Molla rossa Red spring	50 ÷ 350 bar
562571L3005E	VA LV. DI RITEGNO VNR-C Shut-off valve	

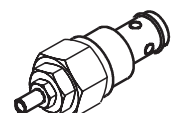

## CORPO CENTRALE DI COLLEGAMENTO VERSIONE "HA" CONNECTING CENTRAL HOUSING "HA" VERSION

Codice Code	Tipo Type	Descrizione Description
5620121HYA0P	HA	Corpo nella versione per circuito a Doppio Effetto, predisposto per elettrovalvola a cartuccia, provvisto di valvola di max. Double acting circuit housing, predisposed for solenoid valves, with max pressure valve.

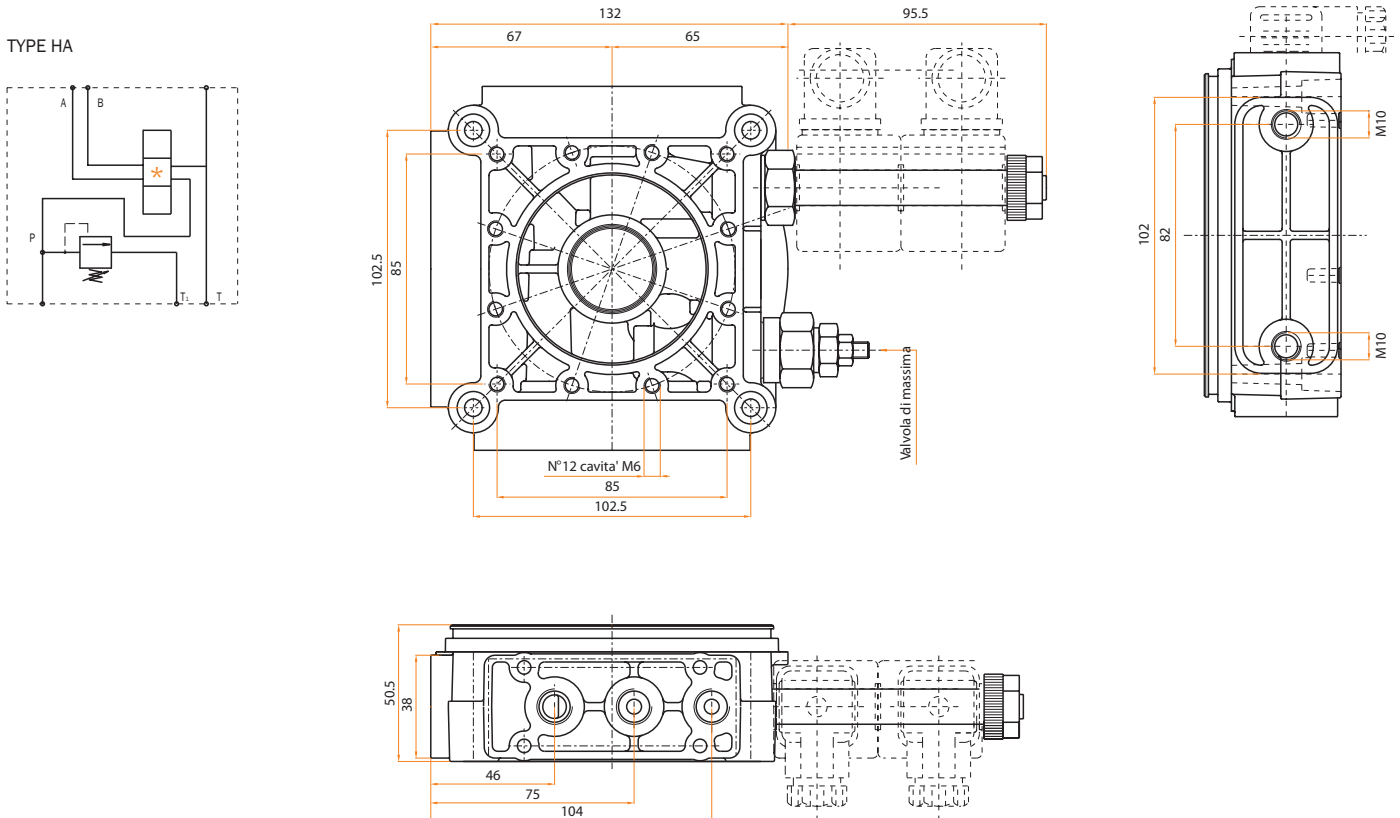

\* Elettrovalvole a cartuccia  
Cartridge solenoid valves

Codice Code	Tipo Type
0874H13A300*	C8C

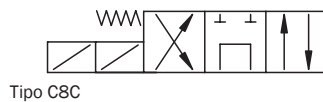

0874H13B300*	C2C
--------------	-----

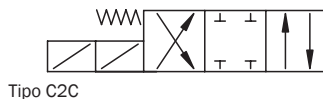

0874H13C300*	C0C
--------------	-----

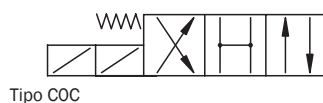

0874H12A300*	C2AL
--------------	------

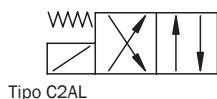

\* Bobina  
Coil

Codice Code	Tipo Type
0891L100A00*	12V
0891L100B00*	24V
0891L100H00*	24V 50Hz
0891L100M00*	110V 50Hz
0891L100N00*	220V 50Hz

**POMPE OLEODINAMICHE HYDRAULIC PUMPS**

Codice Code	Tipo Type	Cilindrata cm <sup>3</sup> /g.	Gruppo Group	Pressione/ Pressure max bar		Velocità max giri/ Max speed gear 1		
				P1	P2	Min.	Max	
<b>Pompa singola ad ingranaggi Single gear pumps</b>								
13B0M2D2BBBC	PS-0/0,25S	0,25	0	210	250	800	6000	
13B0M2D2FBBC	PS-0/0,5S	0,5	0	210	250	800	6000	
13B0M2D2GBBC	PS-0/0,75S	0,75	0	210	250	800	6000	
13B0M2D2ABBJ	UK 0,25/S 18 G	0,18	0	170	200		7000	
13B0M2D2BBBJ	UK 0,25/S 24 G	0,24	0	170	200		7000	
13B0M2D2CBBJ	UK 0,25/S 30 G	0,30	0	170	200		7000	
13B0M2D2DBBJ	UK 0,25/S 36 G	0,36	0	170	200		7000	
13B0M2D2EBBJ	UK 0,25/S 48 G	0,48	0	170	200		7000	
13B0M2D2FBBJ	UK 0,25/S 60 G	0,60	0	170	200		7000	
13B1W2D2ABBC	PS-1/1S	1	1	230	250	800	3500	
13B1W2D2BBBC	PS-1/1,25S	1,25	1	230	250	800	3500	
13B1W2D2CBBC	PS-1/1,6S	1,6	1	230	250	800	3500	
13B1W2D2EBBC	PS-1/2S	2	1	230	250	800	3500	
13B1W2D2GBBC	PS-1/2,5S	2,5	1	230	250	800	3500	
13B1W2D2JBBC	PS-1/3,15S	3,15	1	230	250	800	3500	
13B1W2D2KBBC	PS-1/3,65S	3,65	1	230	250	800	3500	
13B1W2D2MBBC	PS-1/4,2S	4,2	1	230	250	800	3500	
13B1W2D2NBBC	PS-1/5S	5	1	220	250	800	3000	
13B1W2D2QBBC	PS-1/5,7S	5,7	1	190	200	800	3000	
13B1W2D2SBBC	PS-1/6,1S	6,1	1	170	190	800	3000	
13B1W2D2UBBC	PS-1/7,8S	7,8	1	150	170	800	3000	
13B1W2D2VBBC	PS-1/8,8S	8,8	1	130	160	800	3000	

1201PF0054AA

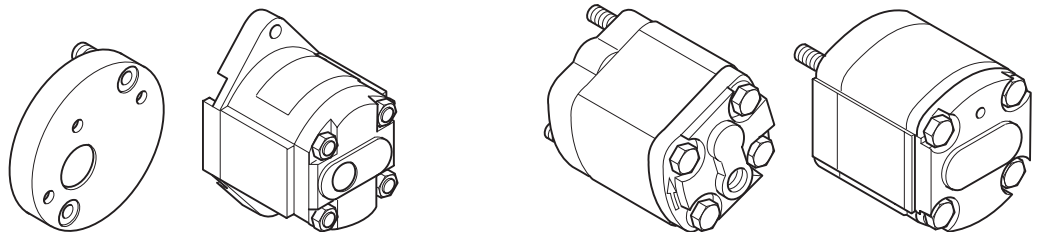
 Kit montaggio  
 pompa Gr. 0  
 Mounting kit  
 for pump group 0

Pompa ad ingranaggi Gr. 1 rotazione sinistra Group 1 gear pump left rotation

**Pompa singola ad ingranaggi Single gear pumps**

13G1W2D2BAAL	PH-1/1,1 S	1,1	1	300	350	1100	6000
13G1W2D2CAAL	PH-1/1,6 S	1,6	1	300	350	950	6000
13G1W2D2EAAL	PH-1/2,1 S	2,1	1	300	350	800	6000
13G1W2D2GAAL	PH-1/2,6 S	2,6	1	300	350	700	5500
13G1W2D2JAAL	PH-1/3,2 S	3,2	1	290	350	600	4500

 I valori di pressione massima P1 sono per funzionamento continuo a 1500 giri/min (Pressione di lavoro). I valori di pressione m  
 The maximum pressure P1 values are for continuous operation at 1500 r.p.m. (Workpressure). The maximum pressure P2 values are f

 assima P2 sono per pressioni di punta a 1500 giri/min (Pressione di punta).  
 or top pressure at 1500 r.p.m. (Top pressure).



## GRUPPO CON POMPA DOPPIA

## GROUP DOUBLE GEAR PUMP

Codice Code	Tipo Type	Cilindrata/ Capacity cm <sup>3</sup> /g.		Pressione/ Pressure max bar		Velocità/ Speed max (g/1')
		1°	2°	1°	2°	
13BWW2A3BMOA	PDH-1 0,24 + 4,2 S	0,24	4,2	450	180	3500
13BWW2A3BSOA	PDH-1 0,24 + 6,1 S	0,24	6,2	450	150	3000
13BWW2A3BUOA	PDH-1 0,24 + 7,8 S	0,24	7,8	450	130	3000
13BWW2A3BVOA	PDH-1 0,24 + 8,8 S	0,24	8,8	450	120	3000
13BWW2A3DMOA	PDH-1 0,34 + 4,2 S	0,34	4,2	450	180	3500
13BWW2A3DSOA	PDH-1 0,34 + 6,1 S	0,34	6,2	450	150	3000
13BWW2A3DUOA	PDH-1 0,34 + 7,8 S	0,34	7,8	450	130	3000
13BWW2A3DVOA	PDH-1 0,34 + 8,8 S	0,34	8,8	450	120	3000
13BWW2A3FMOA	PDH-1 0,60 + 4,2 S	0,6	4,2	450	180	3500
13BWW2A3FSOA	PDH-1 0,60 + 6,1 S	0,6	6,2	450	150	3000
13BWW2A3FUOA	PDH-1 0,60 + 7,8 S	0,6	7,8	450	130	3000
13BWW2A3FVOA	PDH-1 0,60 + 8,8 S	0,6	8,8	450	120	3000
13BWW2A3HMOA	PDH-1 0,94 + 4,2 S	0,94	4,2	450	150	3000
13BWW2A3HSOA	PDH-1 0,94 + 6,1 S	0,94	6,2	450	130	3000
13BWW2A3HUOA	PDH-1 0,94 + 7,8 S	0,94	7,8	450	120	3000
13BWW2A3HVOA	PDH-1 0,94 + 8,8 S	0,94	8,8	450	120	3000
13BWW2A3QMOA	PDH-1 1,65 + 4,2 S	1,65	4,2	450	120	3000
13BWW2A3QSOA	PDH-1 1,65 + 6,1 S	1,65	6,2	450	120	3000
13BWW2A3QUOA	PDH-1 1,65 + 7,8 S	1,65	7,8	450	120	3000
13BWW2A3QVOA	PDH-1 1,65 + 8,8 S	1,65	8,8	450	120	3000

Pompa doppia ad ingranaggi + pistoni con valvola disgiuntrice  
Double gear pump + piston pump with unloading valve

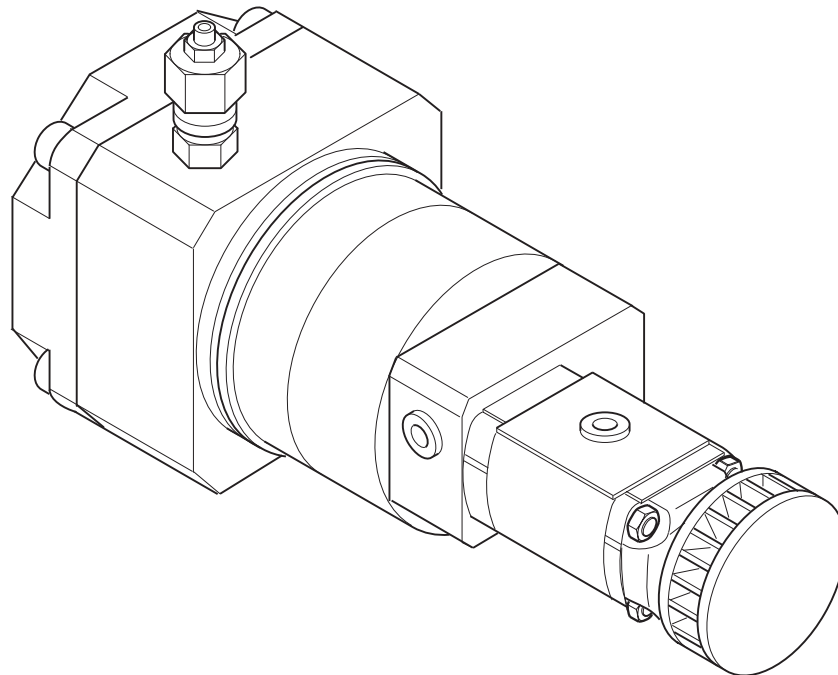



**FILTRI IN ASPIRAZIONE SUCTION FILTERS**

Codice Code	Tipo Type	Dis.	Filetto Thread	Diametro mm	Applicazione Application		Montaggio tubo/Tube assembling		Tipo serbatoio Oil tank type
					OR	VR	Dritto Unistorted	Piegato Turned	
56233A14H0CA	FA-80	1	F 3/8"	80	•	•			
56233C14HACA		2	M 3/8"	80	•	•			
56233D14H0CA	FC-80	3	F 3/8"	80	•	•			
56233C14HACA		2	M 3/8"	80	•				LCE-K5-0010-OR
56233C14HACA		2	M 3/8"	80	•				LCE-K5-0020-OR
56233C14HACA		2	M 3/8"	80	•				LCE-K5-0030-OR
56227B140040	F80/O040		M 3/8"	80	•			•	LCE-K5-0040-OR
56227B140050	F80/O050		M 3/8"	80	•			•	LCE-K5-0050-OR
56227B140051	F80/O051		M 3/8"	80	•			•	LCE-K5-0051-OR
56227B140052	F80/O052		M 3/8"	80	•			•	LCE-K5-0052-OR
56227B140070	F80/O070		M 3/8"	80	•			•	LCE-K5-0070-OR
56227B140080	F80/O080		M 3/8"	80	•			•	LCE-K5-0080-OR
56227B140100	F80/O100	5	M 3/8"	80	•			•	LCE-K5-0100-OR
56227B140150	F80/O150	5	M 3/8"	80	•			•	LCE-K5-0150-OR
56233A14H0CA	F80/V010	2	M 3/8"	80		•	•		LCE-K5-0010-VR
56227A14V020	F80/V020	4	M 3/8"	80		•	•		LCE-K5-0020-VR
56227A14V030	F80/V030	4	M 3/8"	80		•	•		LCE-K5-0030-VR
56227A14V040	F80/V040	4	M 3/8"	80		•	•		LCE-K5-0040-VR
56227A14V050	F80/V050	4	M 3/8"	80		•	•		LCE-K5-0050-VR
56227A14V051	F80/V051	4	M 3/8"	80		•	•		LCE-K5-0051-VR
56227A14V052	F80/V052	4	M 3/8"	80		•	•		LCE-K5-0052-VR
56227A14V070	F80/V070	4	M 3/8"	80		•	•		LCE-K5-0070-VR
56227A14V080	F80/V080	4	M 3/8"	80		•	•		LCE-K5-0080-VR
56227A14V100	F80/V100	4	M 3/8"	80		•	•		LCE-K5-0100-VR
56227A14V150	F80/V150	4	M 3/8"	80		•	•		LCE-K5-0150-VR

DIS. 1

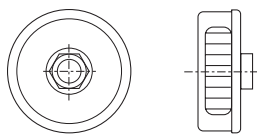
 Filtro metallico cilindrico aspirazione parziale  
 Metallic cilindric filter partial aspiration

DIS. 2

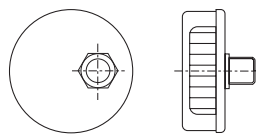
 Filtro metallico cilindrico attacco eccentrico  
 aspirazione parziale  
 Metallic cilindric filter eccentric  
 connection partial aspiration

DIS. 3

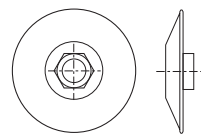
 Filtro metallico trapezoidale aspirazione totale  
 Metallic cilindric filter total aspiration

DIS. 4

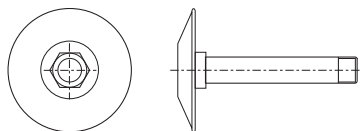
 Applicazione del tubo diritto  
 Application of the unistorted tube

DIS. 5

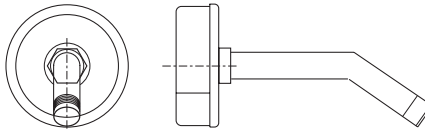

 Applicazione del tubo piegato  
 Application of the turned tube

SERBATOI OLIO PER MINICENTRALINE

MINI POWER PACK'S STEEL OIL TANK

Codice Code	Tipo Type	Volume (litri)	A	B	C	D	E	F	Dis.
56221103A23Z	LCE - K5 - 0010	1	123	139	6.5	125	102.5	129.5	1
56221101A30Z	LCE - K5 - 0011	1	123	139	6.5	125	102.5	129.5	2
39G52D000C0C	<b>TAPPO CAP 1/2" G</b>	Tappo carico olio Oil filler cap							

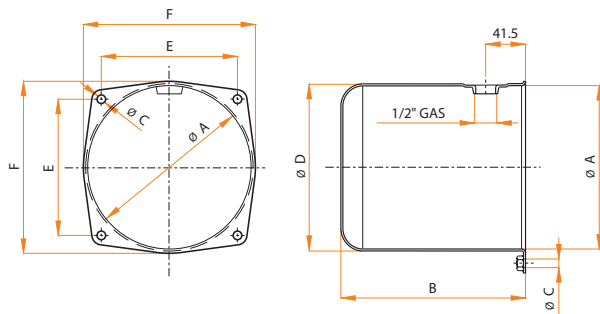
DIS. 1



DIS. 2

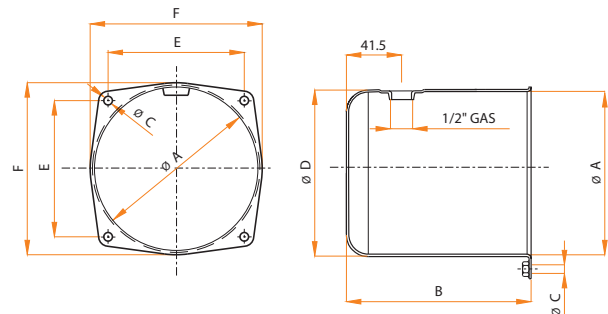

56221203A23Z	LCE - K5 - 0020	2	123	217.5	6.5	125	102.5	129.5	1
56221252A23Z	LCE - K5 - 0025	2	123	217.5	6.5	125	102.5	129.5	2
39G52D000C0C	<b>TAPPO CAP 1/2" G</b>	Tappo carico olio Oil filler cap							

DIS. 1

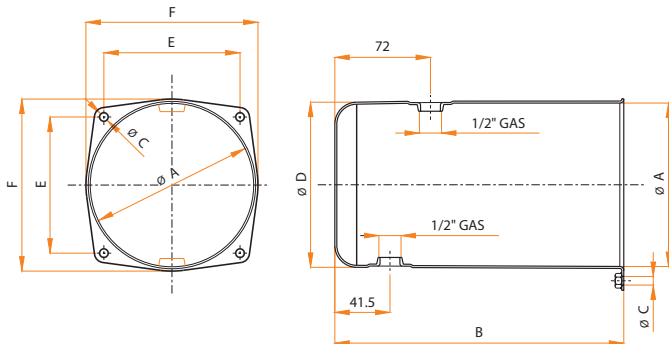

DIS. 2

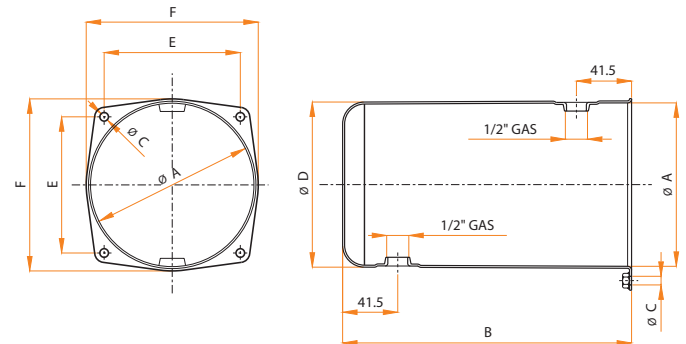

**SERBATOI OLIO PER MINICENTRALINE**
**MINI POWER PACK'S STEEL OIL TANK**

Codice Code	Tipo Type	Volume (litri)	A	B	C	D	E	F	Dis.
56221303A23Z	LCE - K5 - 0030	3	123	290	6.5	125	102.5	129.5	1
56221313A23Z	LCE - K5 - 0031	3	123	290	6.5	125	102.5	129.5	2
39G52D000C0C	<b>TAPPO CAP 1/2" G</b>	Tappo carico olio Oil filler cap							

DIS. 1

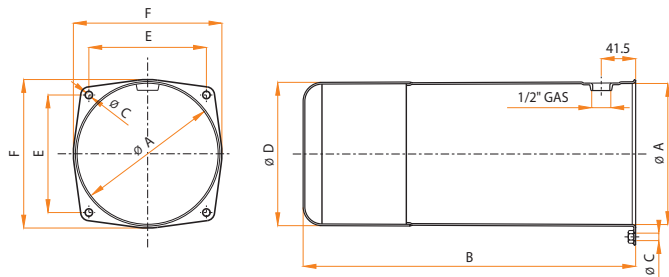

DIS. 2

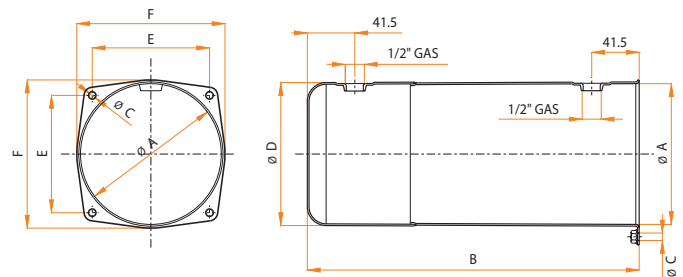

56221403A23Z	LCE - K5 - 0040	4	123	234.5	6.5	170	102.5	129.5	1
56221413A23Z	LCE - K5 - 0041	4	123	234.5	6.5	170	102.5	129.5	2
56221423A23Z	LCE - K5 - 0042	4	123	234.5	6.5	170	102.5	129.5	3
39G52D000C0C	<b>TAPPO CAP 1/2" G</b>	Tappo carico olio Oil filler cap							

DIS. 1

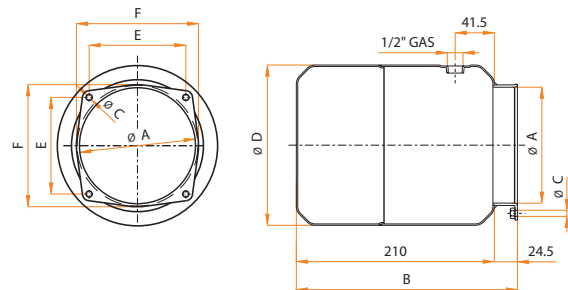

DIS. 2

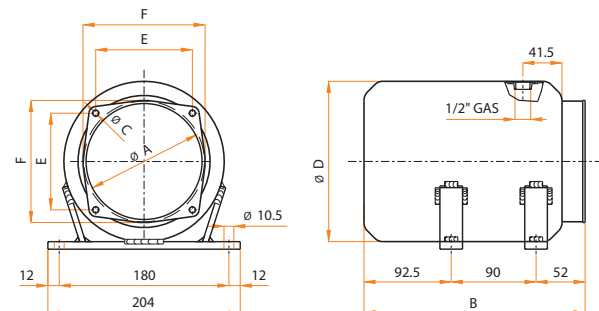

DIS. 3

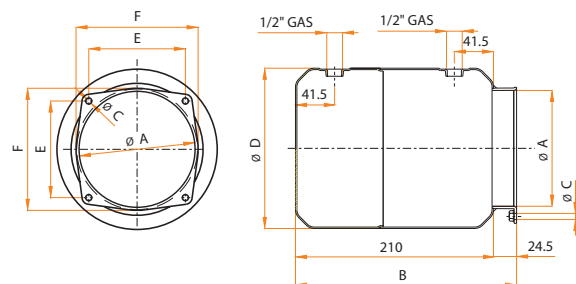

SERBATOI OLIO PER MINICENTRALINE

MINI POWER PACK'S STEEL OIL TANK

Codice Code	Tipo Type	Volume (litri)	A	B	C	D	E	F	Dis.
56221503A23Z	LCE - K5 - 0050	5	123	204.5	6.5	200	102.5	129.5	1
56221513A23Z	LCE - K5 - 0051	5	123	270.5	6.5	170	102.5	129.5	2
56221523B23Z	LCE - K5 - 0052	5	123	190	9	172	150	220	3
56221533A23Z	LCE - K5 - 0053	5	123	208.5	6.5	200	102.5	129.5	4

  

39G52D000C0C	<b>TAPPO CAP 1/2" G</b>	Tappo carico olio Oil filler cap							
--------------	-------------------------	----------------------------------	--	--	--	--	--	--	--

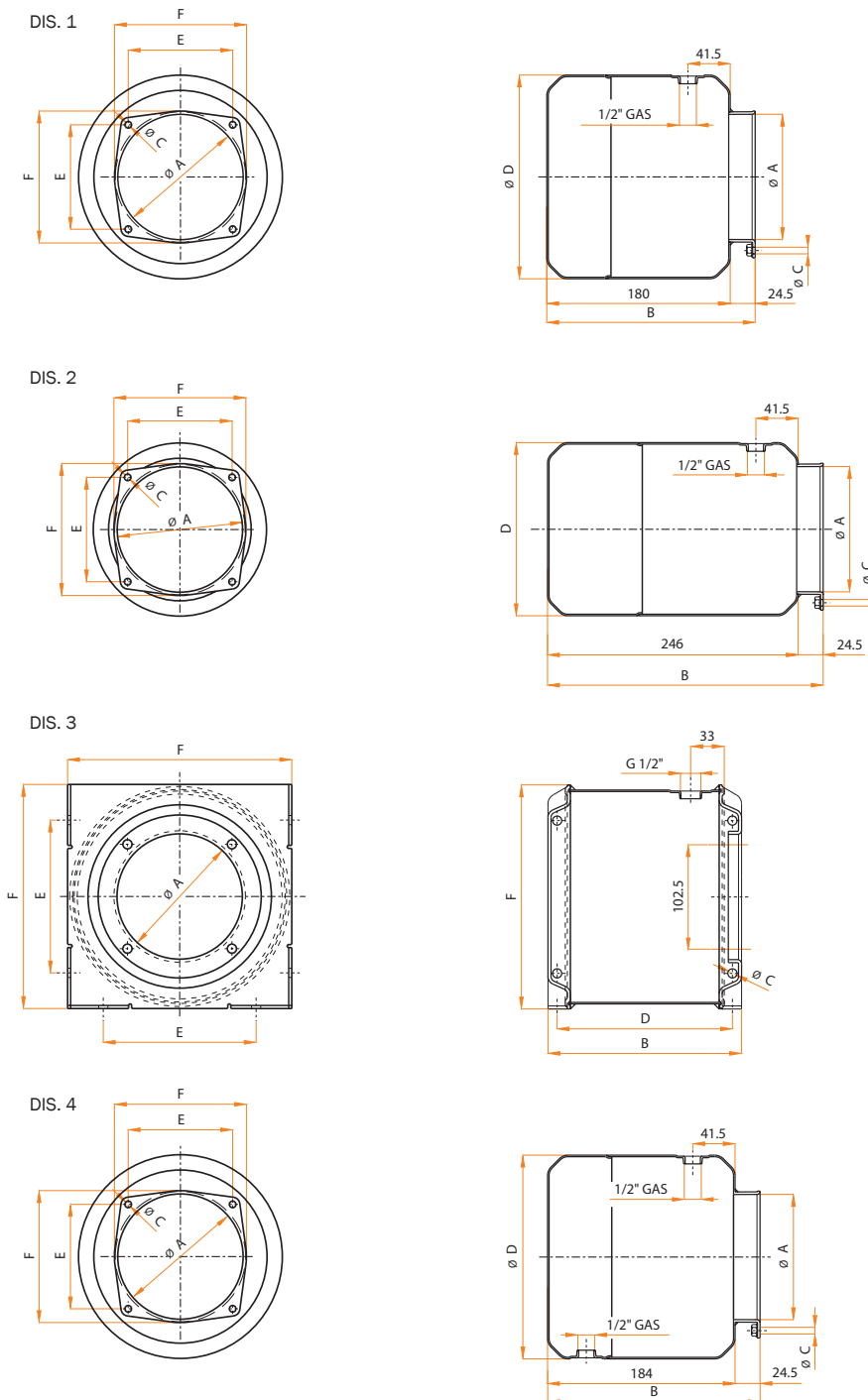

**SERBATOI OLIO PER MINICENTRALINE**
**MINI POWER PACK'S STEEL OIL TANK**

Codice Code	Tipo Type	Volume (litri)	A	B	C	D	E	F	Dis.
56221703A23Z	LCE - K5 - 0070	7	123	264.5	6.5	200	102.5	129.5	1
56221713A23Z	LCE - K5 - 0071	7	123	264.5	6.5	200	102.5	129.5	2
56221723A23Z	LCE - K5 - 0072	7	123	264.5	6.5	200	102.5	129.5	3
56221753A23Z	LCE - K5 - 0075	7	123	264.5	6.5	200	102.5	129.5	4
56221733B23Z	LCE - K5 - 0073	7	123	250	9	232	150	220	5
56221743B23Z	LCE - K5 - 0074	7	123	250	9	232	150	220	6
39G52D000C0C	<b>TAPPO CAP 1/2" G</b>	Tappo carico olio	Oil filler cap						
39G52E000C0C	<b>TAPPO CAP 3/4" G</b>	Tappo carico olio	Oil filler cap						

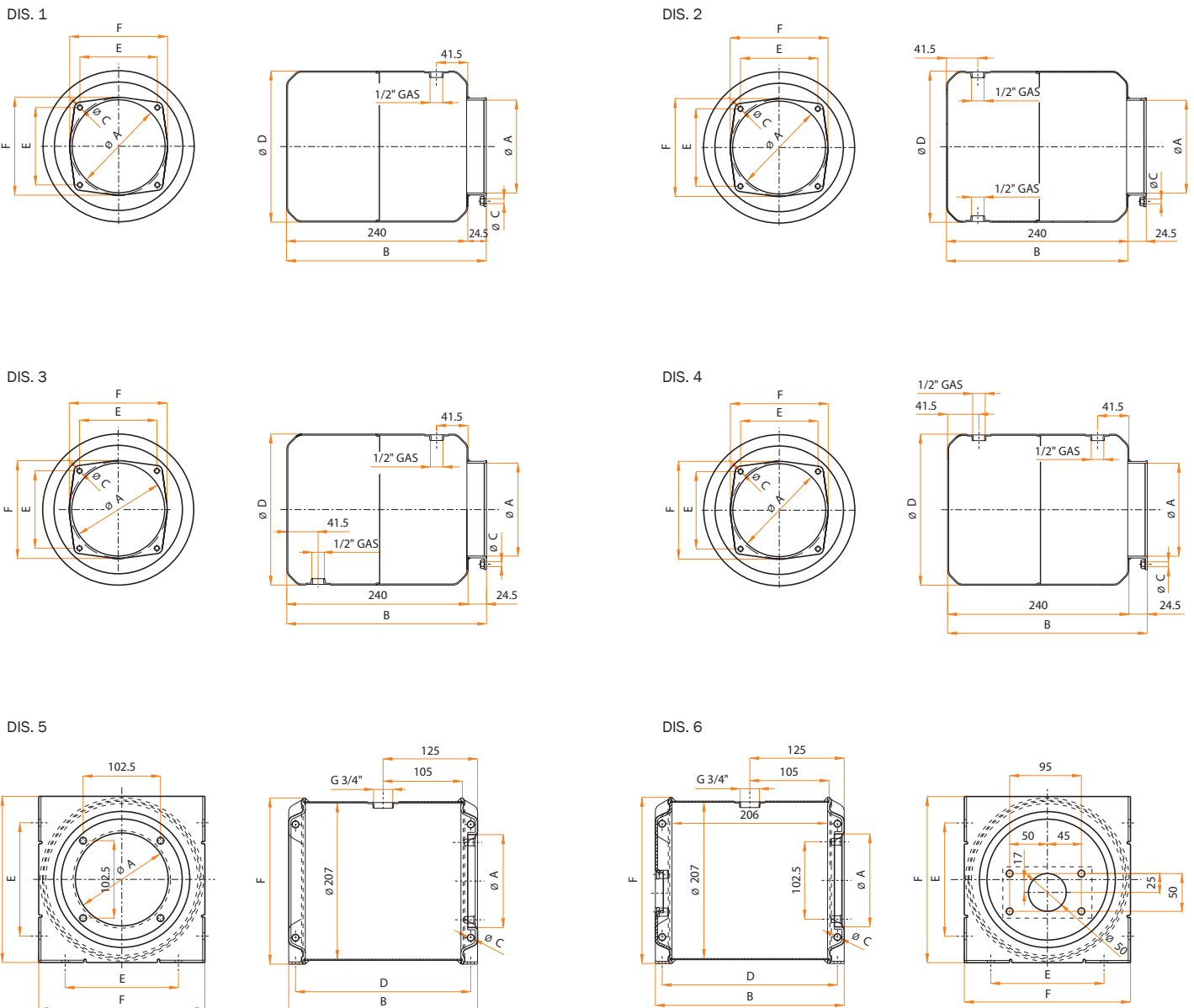
 Serbatoio con foratura per pompa a mano  
 Tank suitable for hand pump

## SERBATOI OLIO PER MINICENTRALINE

## MINI POWER PACK'S STEEL OIL TANK

Codice Code	Tipo Type	Volume (litri)	A	B	C	D	E	F	Dis.
56221833A23Z	LCE - K5 - 0083	8	123	384.5	6.5	170	102.5	129.5	1
56221801A34T	LCE - K5 - 0081	8	123	269.5	6.5	200	102.5	129.5	2
56221801B30T	LCE - K5 - 0082	8	123	269.5	6.5	200	102.5	129.5	3
56221803B23Z	LCE - K5 - 0080	8	123	290	9	272	150	220	4

  

39G52D000C0C	<b>TAPPO CAP 1/2" G</b>	Tappo carico olio	Oil filler cap
39G52E000C0C	<b>TAPPO CAP 3/4" G</b>	Tappo carico olio	Oil filler cap

DIS. 1

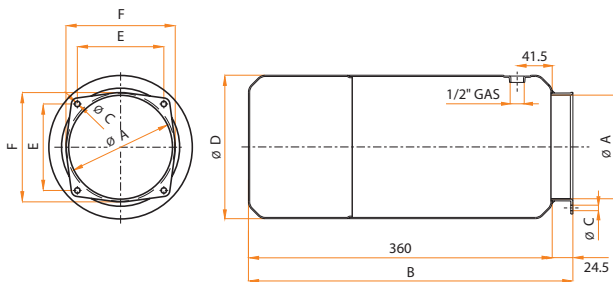

DIS. 2

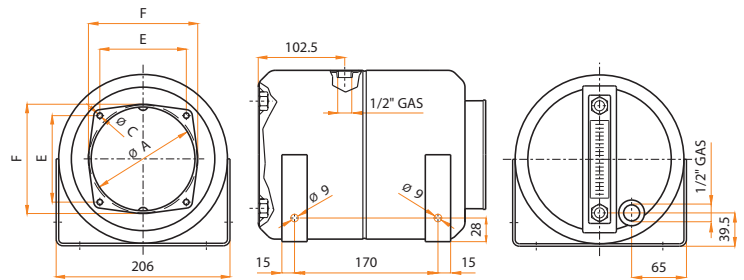

DIS. 3

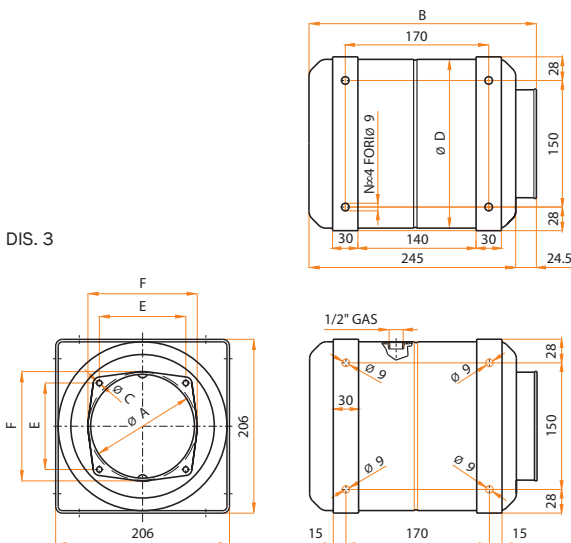

DIS. 4

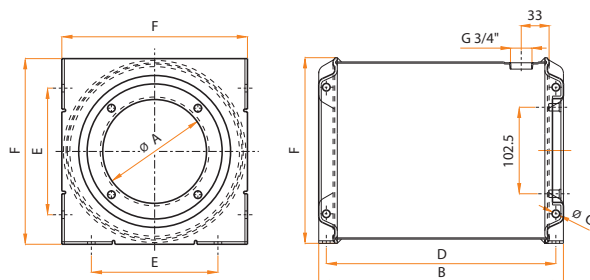

**SERBATOI OLIO PER MINICENTRALINE MINI POWER PACK'S STEEL OIL TANK**

Codice Code	Tipo Type	Volume (litri)	A	B	C	D	E	F	Dis.
56221A03B23Z	LCE - K5 - 0100	10	123	340	9	322	150	220	1
56221A13B23Z	LCE - K5 - 0101	10	123	340	9	322	150	220	2
39G52E000C0C	<b>TAPPO CAP 3/4"G</b>	Tappo carico olio Oil filler cap							

DIS. 1

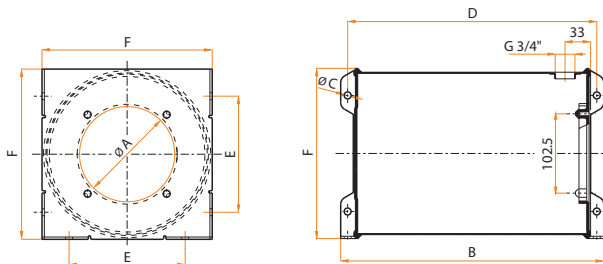

DIS. 2

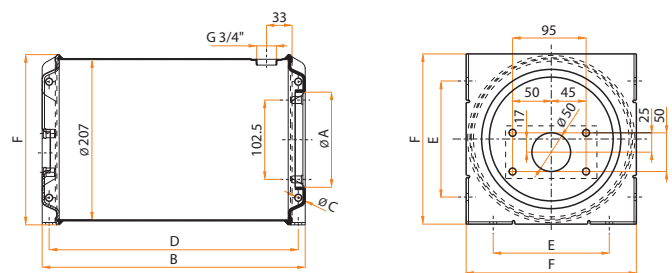

SERBATOIO CON FORATURA PER POMPA A MANI SUITABLE FOR HAND PUMP

56221A53B23Z	LCE - K5 - 0150	15	123	490	9	472	150	220	1
56221A5AB23Z	LCE - K5 - 0151	15	123	490	9	472	150	220	2
56221A5BB23Z	LCE - K5 - 0152	15	123	490	9	472	150	220	3
39G52E000C0C	<b>TAPPO CAP 3/4"G</b>	Tappo carico olio Oil filler cap							

DIS. 1

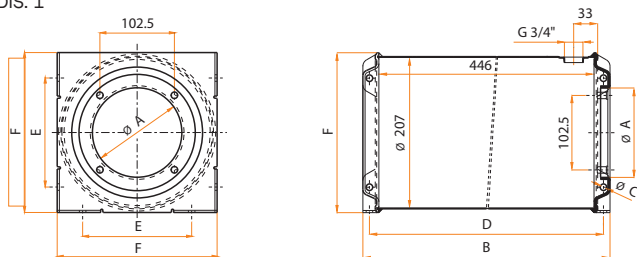

DIS. 2

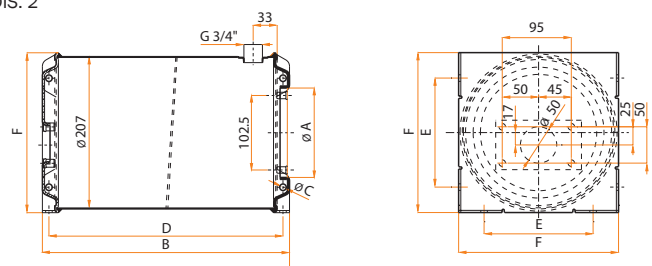

SERBATOIO CON FORATURA PER POMPA A MANI SUITABLE FOR HAND PUMP

DIS. 3

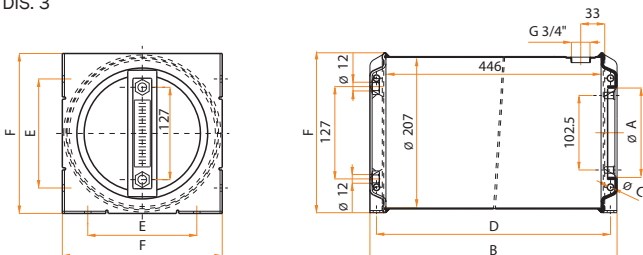

## SERBATOI OLIO PER MINICENTRALINE

## MINI POWER PACK'S STEEL OIL TANK

Codice Code	Tipo Type	Volume (litri)	A	B	C	D	E	F	Dis.
56221833A23Z	LCE - K5 - 0083	8	123	384.5	6.5	170	102.5	129.5	1
56221801A34T	LCE - K5 - 0081	8	123	269.5	6.5	200	102.5	129.5	2
56221801B30T	LCE - K5 - 0082	8	123	269.5	6.5	200	102.5	129.5	3
56221803B23Z	LCE - K5 - 0080	8	123	290	9	272	150	220	4

  

39G52D000C0C	<b>TAPPO CAP 1/2" G</b>	Tappo carico olio	Oil filler cap
39G52E000C0C	<b>TAPPO CAP 3/4" G</b>	Tappo carico olio	Oil filler cap

DIS. 1

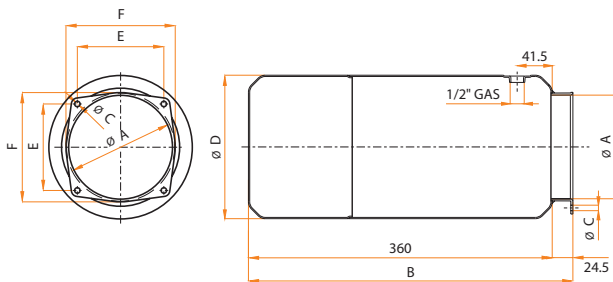

DIS. 2

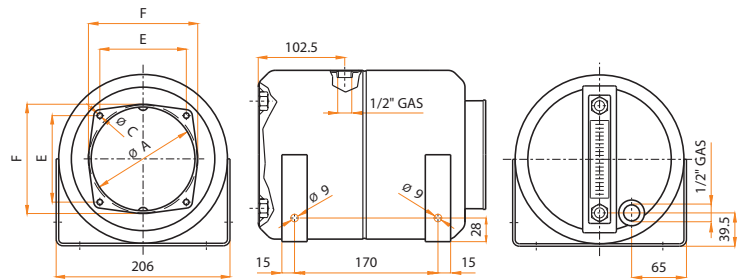

DIS. 3

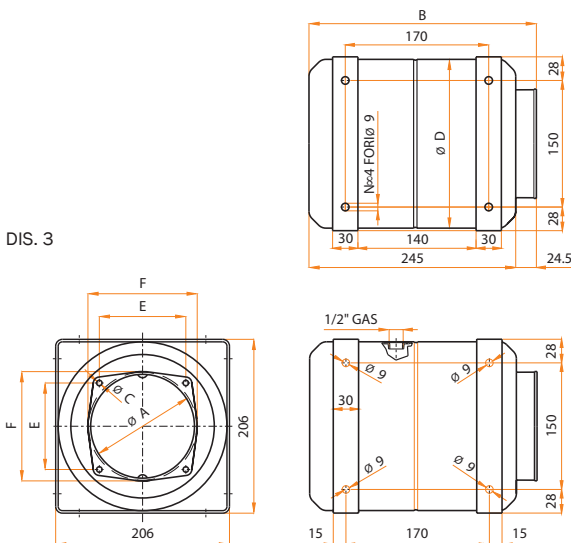

DIS. 4

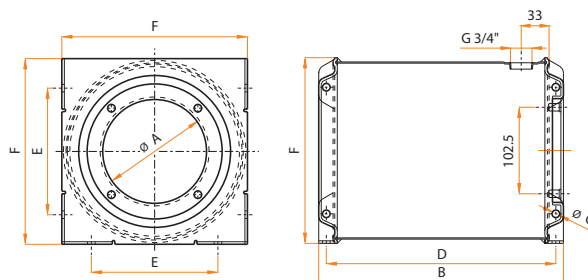



**SERBATOI OLIO PER MINICENTRALINE MINI POWER PACK'S STEEL OIL TANK**

Codice Code	Tipo Type	Volume (litri)	A	B	C	D	E	F	Dis.
56221A03B23Z	LCE - K5 - 0100	10	123	340	9	322	150	220	1
56221A13B23Z	LCE - K5 - 0101	10	123	340	9	322	150	220	2
39G52E000C0C	<b>TAPPO CAP 3/4"G</b>	Tappo carico olio Oil filler cap							

DIS. 1

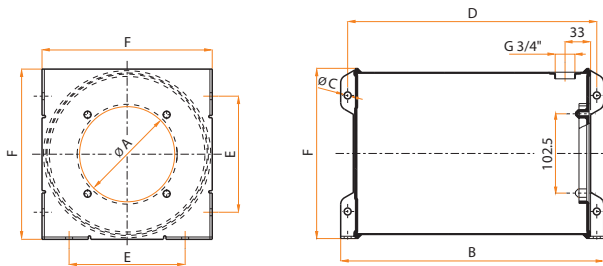

DIS. 2

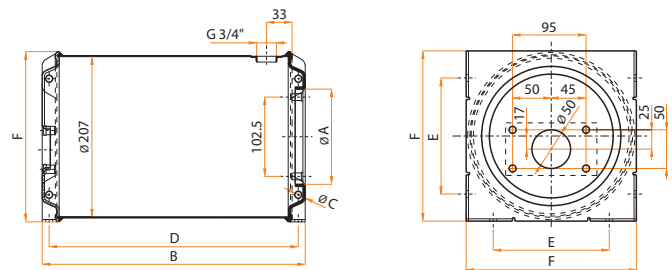

SERBATOIO CON FORATURA PER POMPA A MANI SUITABLE FOR HAND PUMP

56221A53B23Z	LCE - K5 - 0150	15	123	490	9	472	150	220	1
56221A5AB23Z	LCE - K5 - 0151	15	123	490	9	472	150	220	2
56221A5BB23Z	LCE - K5 - 0152	15	123	490	9	472	150	220	3
39G52E000C0C	<b>TAPPO CAP 3/4"G</b>	Tappo carico olio Oil filler cap							

DIS. 1

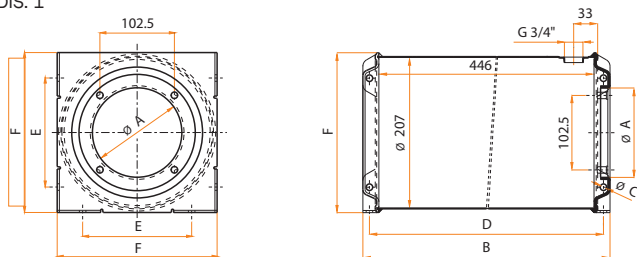

DIS. 2

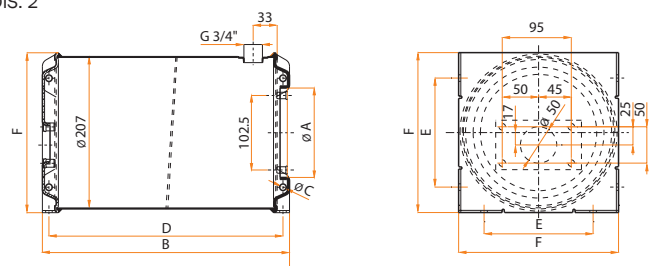

SERBATOIO CON FORATURA PER POMPA A MANI SUITABLE FOR HAND PUMP

DIS. 3

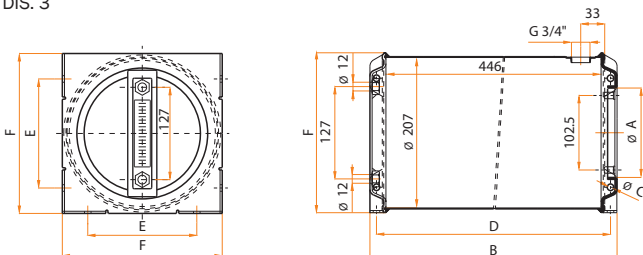

SERBATOI OLIO PER MINICENTRALINE

MINI POWER PACK'S STEEL OIL TANK

Codice Code	Tipo Type	Volume (litri)	A	B	C	D	E	F	Dis.
56221A83B23Z	LCE - K5 - 0180	23	123	490	9	285	200	270	1
39G52E000C0C	<b>TAPPO CAP 3/4"G</b>	Tappo carico olio Oil filler cap							

DIS. 1

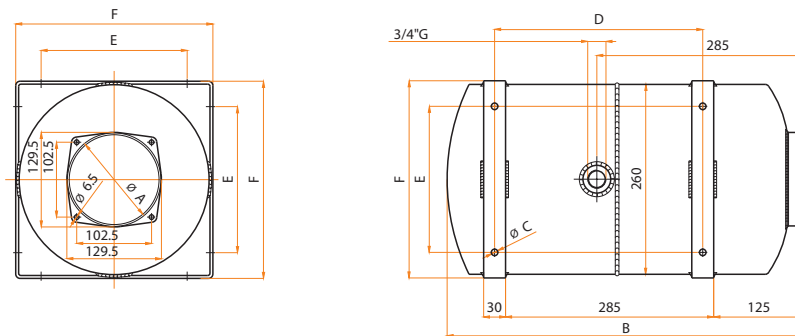

56221C03B23Z	LCE - K5 - 0300	30	123	394.5	9	320	200	328	1
39G52F000C0C	<b>TAPPO CAP 1"G</b>	Tappo carico olio Oil filler cap							

DIS. 1

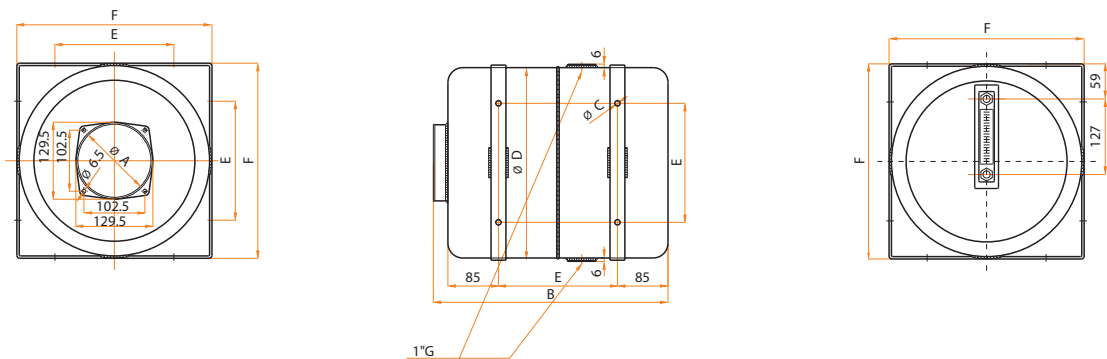

**SERBATOI OLIO PER MINICENTRALINE**
**MINI POWER PACK'S STEEL OIL TANK**

Codice Code	Tipo Type	Volume (litri)	A	B	C	D	E	F	Dis.
56221D53B23Z	LCE - K5 - 0450	45	123	569.5	9	360	200	328	1
39G52F000C00	<b>TAPPO CAP 1" G</b>	Tappo carico olio Oil filler cap							

DIS. 1

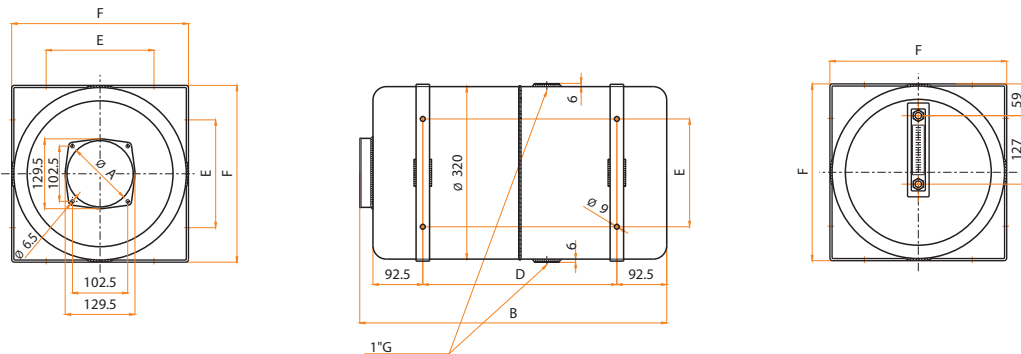

**TAPPI SERBATOI OLIO PER MINICENTRALINE**
**MINI POWER PACK'S OIL CAP**

Codice Code	Tipo Type	Dis.
39G52D000C0C	<b>TAPPO CAP 1/2" G</b>	1
39G52E000C0C	<b>TAPPO CAP 3/4" G</b>	2
39G52F000C00	<b>TAPPO CAP 1" G</b>	3

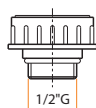
DIS. 1

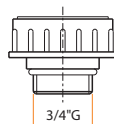

DIS. 2

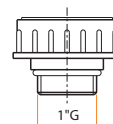

DIS. 3

**COLLARE PER SERBATOIO**
**OIL TANKS FLANGE**

56220123000Z	1
--------------	---

DIS. 1

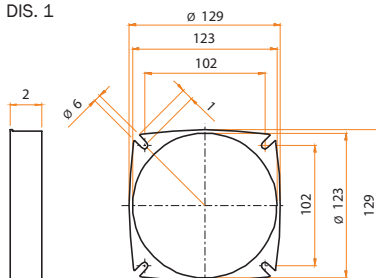

## SERBATOI OLIO IN PLASTICA PER MINICENTRALINE

equipaggiati con capottina in plastica per il montaggio di corpi hy 10 con max 5 elettrovalvole

## MINI POWER PACK'S PLASTIC OIL TANK

equipped with plastic cover suitable for hy 10 manifold with max 5 solenoid valves

Codice Code	Tipo Type	A	B	C	D	E	F	G	H	I	L
56ZP3080010C	Termoplast lt. 10	200	328	272	278	250	70	170	270	176,5	
56ZP3080020C	Termoplast lt. 20	350	328	272	278	250	220	320	420	176,5	
56ZP3070009C	Cuffia tipo 1 Cover type 1		328	272	278	250	70	170	270	176,5	285
56ZP3070020C	Cuffia tipo 2 Cover type 2		328	272	278	250	220	320	470	176,5	355

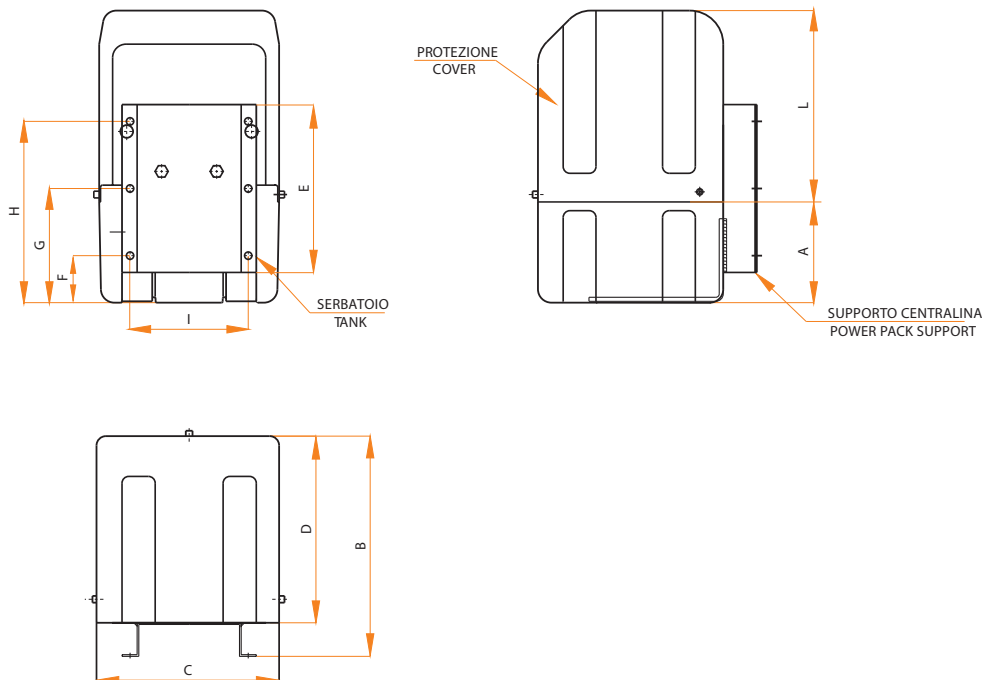

Codice Code	Tipo Type
2300PS0054BO	Supporto Termoplast lt. 10 Support Termoplast lt. 10
2300PS05900A	Supporto Termoplast lt. 20 Support Termoplast lt. 20
39G52E000C0C	Tappo carico olio Oil filler cap

**SERBATOI OLIO IN PLASTICA PER MINICENTRALINE**
**MINI POWER PACK'S PLASTIC OIL TANK**

Codice Code	Tipo Type	Volume (litri)	A	B	C	D	E	F	Dis.
-------------	-----------	----------------	---	---	---	---	---	---	------

**SERBATOI IN PLASTICA VERSIONE ORIZZONTALE**
**PLASTIC TANK HORIZONTAL POSITION**

56220201B00E	PLASTICA PLASTIC	1.5	145	190	170	170	123.2	131.6	1
56220301B00E	PLASTICA PLASTIC	3	200	190	170	170	123.2	131.6	1
56220501B00E	PLASTICA PLASTIC	5	287	190	170	170	123.2	131.6	1
56220701B00E	PLASTICA PLASTIC	8	377	190	170	170	123.2	131.6	1

**SERBATOI IN PLASTICA VERSIONE VERTICALE**
**PLASTIC TANK VERTICAL POSITION**

56220201B01E	PLASTICA PLASTIC	1.5	145	190	170	170	123.2	131.6	1
56220301B02E	PLASTICA PLASTIC	3	200	190	170	170	123.2	131.6	1
56220501B02E	PLASTICA PLASTIC	5	287	190	170	170	123.2	131.6	1
56220701B02E	PLASTICA PLASTIC	8	377	190	170	170	123.2	131.6	1

**TAPPO PER SERBATOI IN PLASTICA ORIZZONTALE E VERTICALE**
**PLASTIC TANK'S FILLER OIL CAP VERTICAL AND HORIZONTAL POSITION**

39G57B000C0C	A PRESSIONE OF PRESSURE								2
--------------	-------------------------	--	--	--	--	--	--	--	---

56325132002A	Kit fissaggio serbatoi	Tank fixing kit							
--------------	------------------------	-----------------	--	--	--	--	--	--	--

DIS. 1

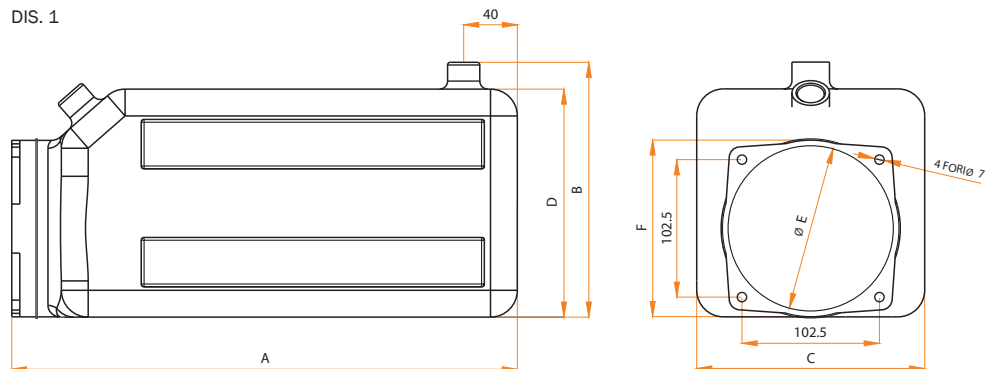

DIS. 2

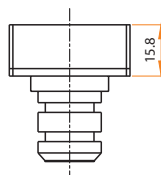

## SUPPORTO MONTAGGIO CENTRALINA MOUNTING SUPPORT FOR POWER PACK

con serbatoio fino a 15 litri oil tank up to 15 liters

Tipo Type	Posizione di fissaggio della centralina Fixing position of the power pack	Disegno Drawing
OR1	Montaggio a pavimento Floor assembling	1
OR2	Montaggio a soffitto Ceiling assembling	2
OR3	Montaggio laterale DX Right side assembling	3
OR4	Montaggio laterale SX Left side assembling	4
VR1	Montaggio motore verso basso Bottom direction of motor assembling	5
VR2	Montaggio motore verso alto Top direction of motor assembling	6

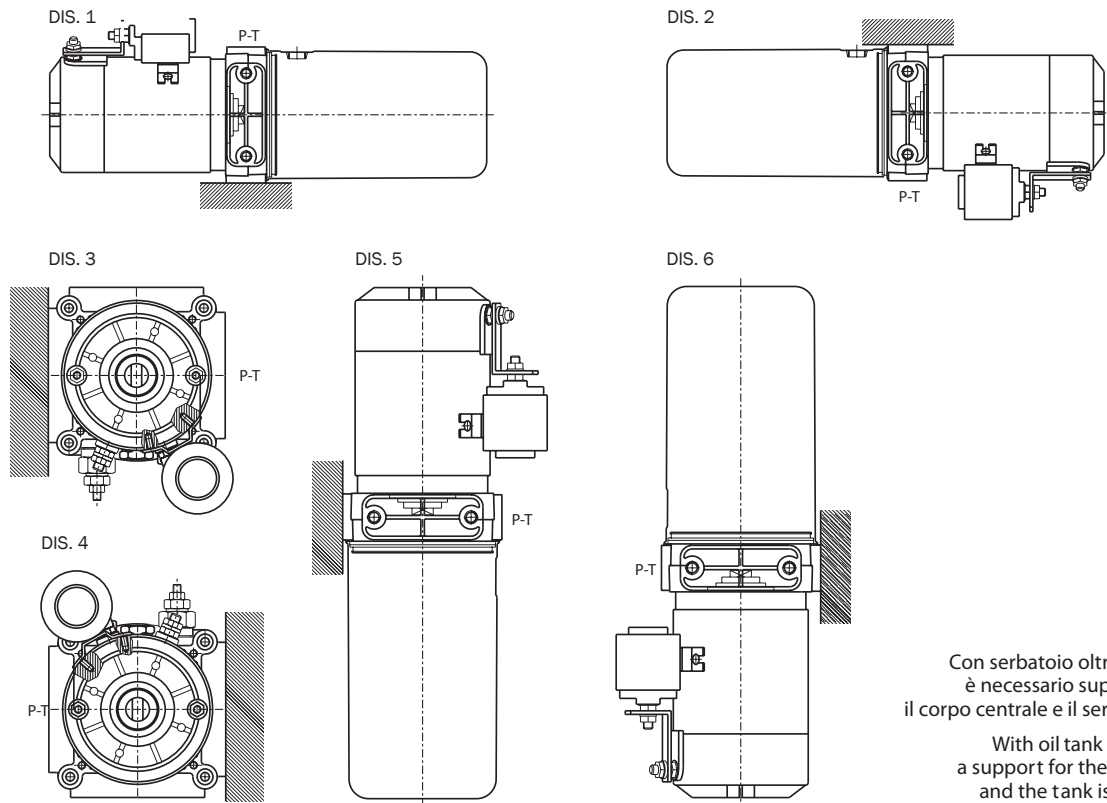



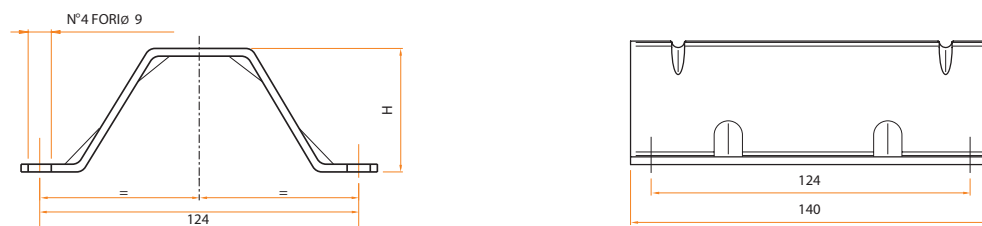

## SUPPORTO MONTAGGIO MOUNTING SUPPORT

Codice Code	Tipo Type
5623512400BA	Supporto Support H=28
56235124000A	Supporto Support H=48

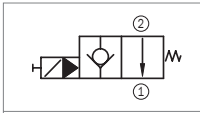

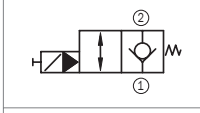
## VALVOLE A CARTUCCIA CARTRIDGE VALVE

Codice Code	Descrizione Description	Schema Scheme
Valvola a due vie a comando elettrico Two-ways valve with electric drive		
	Normalmente aperte Normally open	
562611L40B0E	Valvola Valve VEI-8A2A06.18K02.17	
562611L40B1F	Valvola Valve VEI-8A2A06.18K02.19	Diseccitata 
	Normalmente chiuse Normally closed	
562611L40A0E	Valvola Valve VEI-8A2A06.18K05.37	
562611L40E0E	Valvola Valve VEI-8A2A06.18K05.47	Diseccitata 
		Eccitata 

Sono disponibili su richiesta altri tipi di circuito. Other circuits on request.

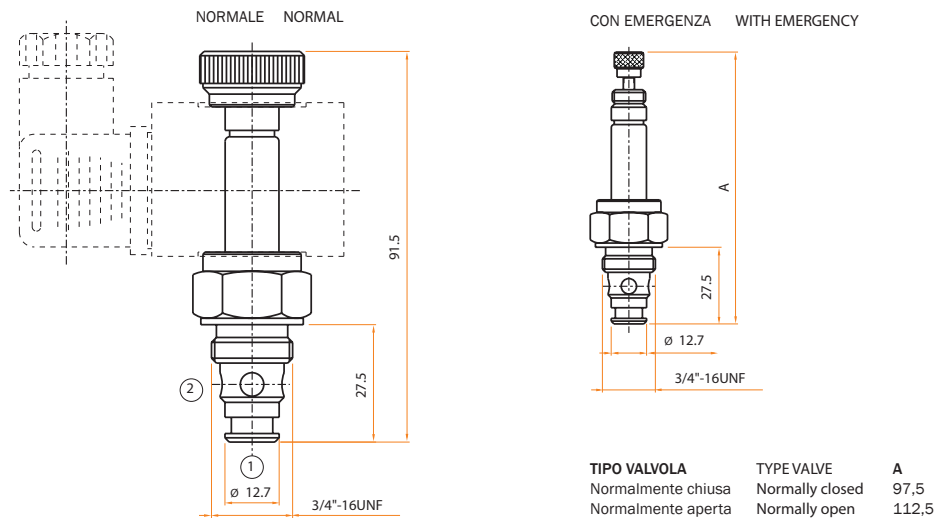

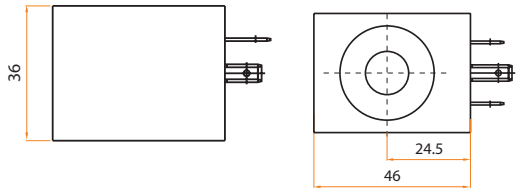
Codice Code	Descrizione Description	Disegno bobina Coil drawing
Bobina Coil		
56263610E02E	Bobina Coil S8H12.7 12V DC. 19W	
56263610E04E	Bobina Coil S8H12.7 24V DC. 17W	
56263610E05E	Bobina Coil S8H12.7 48V DC. 19W	
56263610E09E	Bobina Coil S8H12.7 24V RAC 19W	
56263610E09F	Bobina Coil S8H12.7 48V RAC 19W	
56263610E0AE	Bobina Coil S8H12.7 110V RAC 19W	
56263610E0BE	Bobina Coil S8H12.7 220V RAC 17W	

Bobina per servizio continuo. Coil for non stop service.

Sono disponibili su richiesta altri tipi di tensioni. Other voltages on request.

## VALVOLE A CARTUCCIA CARTRIDGE VALVE

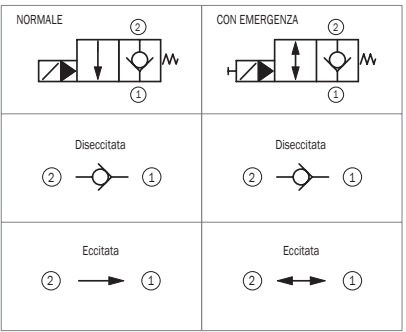
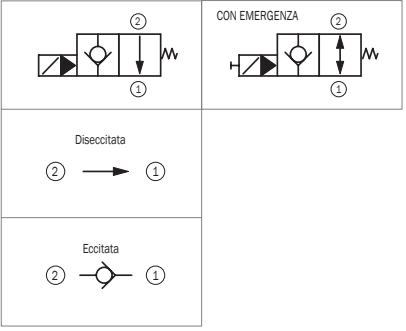
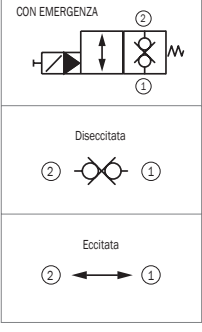
Codice Code	Descrizione Description	Schema Scheme
<b>Valvola a due vie a comando elettrico Two-ways valve with electric drive</b>		
Normalmente chiuse Normally closed		
562611L40A0A	Valvola Valve WS-08Z-01-C-N-12 DG	
562611L40A0C	Valvola Valve WS-08Z-01-C-N-12 DL	
562611L40A0D	Valvola Valve WS-08Z-01-C-N-24 DG	
562611L40A0B	Valvola Valve WS-08Z-01-C-N-24 DL	
562611L40E2D	Valvola Valve WS-08ZR-01M-C-N-12 DG con emergenza with emergency	
562611L40E4D	Valvola Valve WS-08ZR-01M-C-N-12 DL con emergenza with emergency	
562611L40E3D	Valvola Valve WS-08ZR-01M-C-N-24 DG con emergenza with emergency	
562611L40E5D	Valvola Valve WS-08ZR-01M-C-N-24 DL con emergenza with emergency	
Normalmente aperte Normally open		
562611M0137H	Valvola Valve WS-08Y-01-C-N-12 DG	
562611M0137F	Valvola Valve WS-08Y-01-C-N-12 DL	
562611M0137L	Valvola Valve WS-08Y-01-C-N-24 DG	
562611M0137G	Valvola Valve WS-08Y-01-C-N-24 DL	
562611M0137Q	Valvola Valve WS-08Y-01M-C-N-12 DG con emergenza with emergency	
562611M0137R	Valvola Valve WS-08Y-01M-C-N-24 DG con emergenza with emergency	
Normalmente chiuse doppia tenuta Normally closet double retain		
562611M3137B	Valvola Valve WS-08W-01M-C-N-12 DG con emergenza with emergency	
562611M3136A	Valvola Valve WS-08W-01M-C-N-12 DL con emergenza with emergency	
562611M3137C	Valvola Valve WS-08W-01M-C-N-24 DG con emergenza with emergency	
562611M3136B	Valvola Valve WS-08W-01M-C-N-24 DL con emergenza with emergency	

Codice Code	Descrizione Description
<b>Bobina Coil</b>	
5626361120DG	Bobina Coil WS08 12V DG
5626361120DL	Bobina Coil WS08 12V DL
5626361240DG	Bobina Coil WS08 24V DG
5626361240DL	Bobina Coil WS08 24V DL

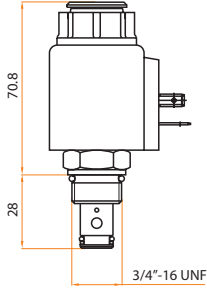

CON EMERGENZA  
WITH EMERGENCY

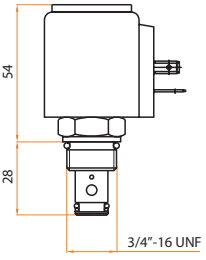

NORMALE  
NORMAL

BOBINE PER VALVOLE NORMALI  
COILS FOR STANDARD VALVE

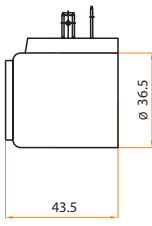

TIPO TYPE DG

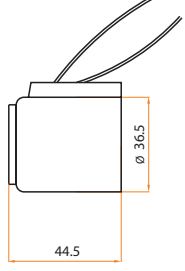

TIPO TYPE DL

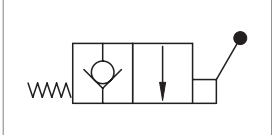
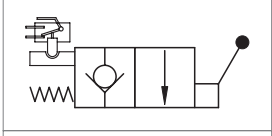
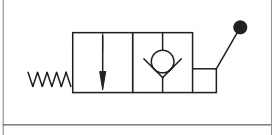
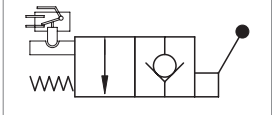

## VALVOLE A CARTUCCIA CARTRIDGE VALVE

Codice Code	Descrizione Description	Schema Scheme	Portata Capacity lt/min	Pressione Pressure bar
Valvola a due vie a comando manuale Two-ways valve with hand drive				
562671L25A3G	Valvola 2 vie comando manuale n.c. senza microinter. mnc-cm e pulsante Two way valve manual operator n.c. without micro-switch mnc-cm and button		25	210
562673L25A3G	Valvola 2 vie comando manuale n.c. con microinter. mnc-cm e pulsante Two way valve manual operator n.c. with micro-switch mnc-cm and button		25	210
562671L25B3G	Valvola 2 vie comando manuale n.a. senza microinter. mna-cm e pulsante Two way valve manual operator n.c. without micro-switch mna-cm and button		25	210
562673L25B3G	Valvola 2 vie comando manuale n.a. con microinter. mna-cm e pulsante Two way valve manual operator n.c. with micro-switch mna-cm and button		25	210

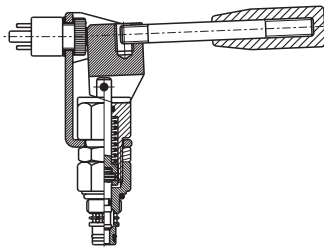

## STROZZATORE COMPENSATO FISSO COMPENSATED THROTTLE

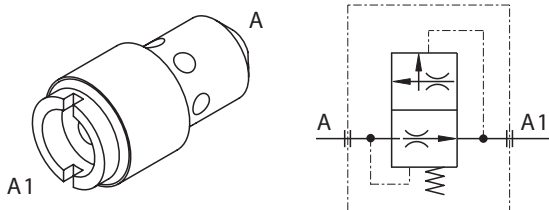

Codice Code	Descrizione Description	Portata Capacity lt/min
3392504A010T	Strozzatore compensato fisso SCF 01 Compensated throttle SCF 01	1
3392504A020T	Strozzatore compensato fisso SCF 02 Compensated throttle SCF 02	2
3392504A030T	Strozzatore compensato fisso SCF 03 Compensated throttle SCF 03	3
3392504A040T	Strozzatore compensato fisso SCF 04 Compensated throttle SCF 04	4
3392504A050T	Strozzatore compensato fisso SCF 05 Compensated throttle SCF 05	5
3392504A060T	Strozzatore compensato fisso SCF 06 Compensated throttle SCF 06	6
3392504A070T	Strozzatore compensato fisso SCF 07 Compensated throttle SCF 07	7
3392504A080T	Strozzatore compensato fisso SCF 08 Compensated throttle SCF 08	8
3392504A090T	Strozzatore compensato fisso SCF 09 Compensated throttle SCF 09	9
3392504A100T	Strozzatore compensato fisso SCF 10 Compensated throttle SCF 10	10



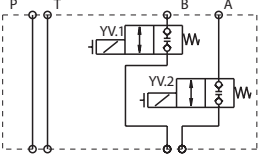
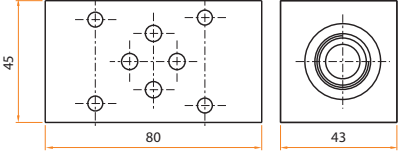
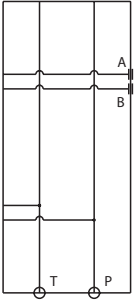
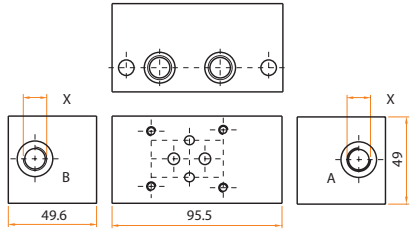
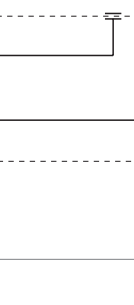
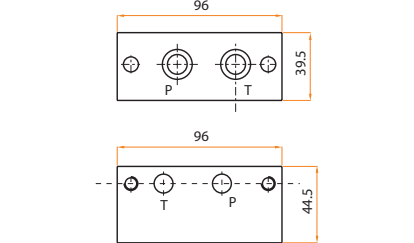
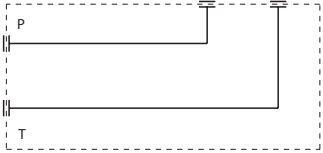
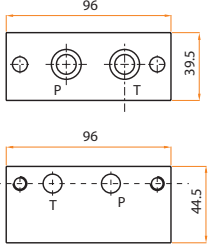
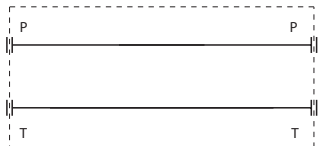
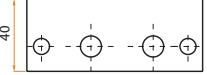
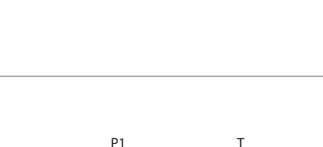
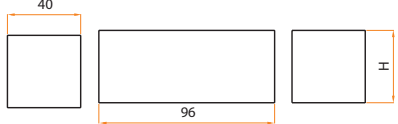
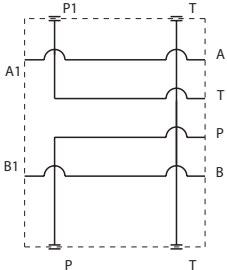
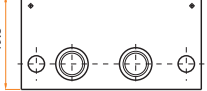
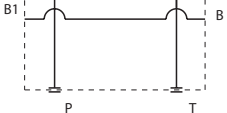
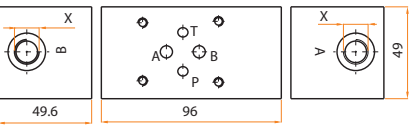

## PIASTRE MODULARI MODULAR PLATES

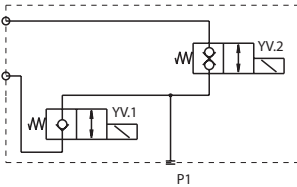
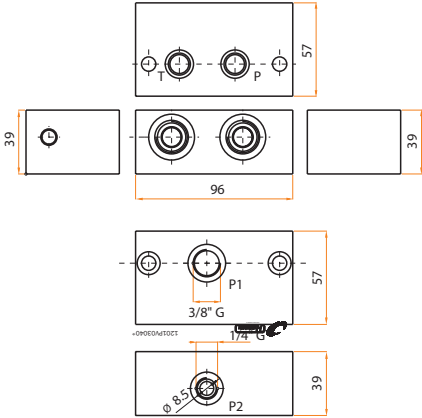
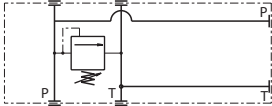
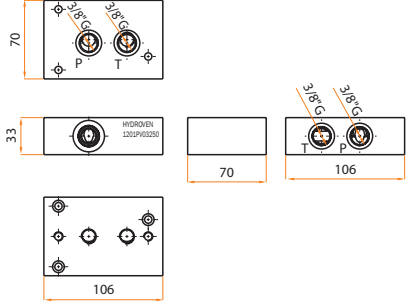
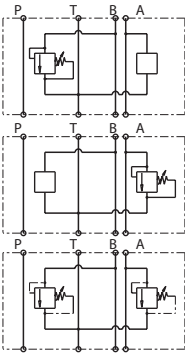
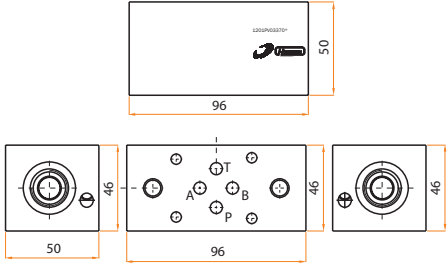
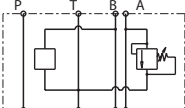
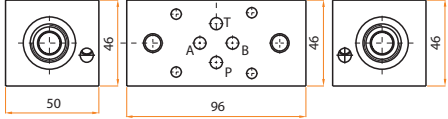
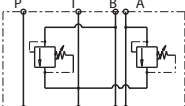
Codice Code	Descrizione Description	Schema Scheme	Disegno Drawing
1201E020227P	<p>Elemento modulare per HY10 per valvole di blocco a comando elettrico. Le valvole non sono incluse nel blocco.</p> <p>Modular plate for HY10 for unblock valve electric controlled. Valves are not included.</p>		
1201E020231A	<p>Modulo per elettrovalvola CETOP-3. Collegamento in parallelo con uscite X=1/4"G.</p> <p>Plate for CETOP-3 solenoid valve. Parallel connection with 1/4 "G outputs.</p>		
1201PV02940A	<p>Modulo per elettrovalvola CETOP-3. Collegamento in parallelo con uscite X=3/8"G.</p> <p>Plate for cetop-3 solenoid valve. Parallel connection with 3/8 "G outputs.</p>		
1201PV01180A	<p>Modulo per rotazione elettrovalvole orizzontale-verticale.</p> <p>Plate for solenoid valves rotation horizontal-vertical.</p>		
1201PV02310A	<p>Distanziale per elemento modulare H=39,5.</p> <p>Spacer for modular plate H=39,5.</p>		
1201PV02320A	<p>Distanziale per elemento modulare H=19,5.</p> <p>Spacer for modular plate H=19,5.</p>		
1201PV02580A	<p>Modulo per elettrovalvola CETOP-3. Collegamento in serie X=1/4"G.</p> <p>Plate for cetop-3 solenoid valve. Serial connection X=1/4 "G.</p>		
1201PV04710A	<p>Modulo per elettrovalvola CETOP-3. Collegamento in serie X=3/8"G.</p> <p>Plate for cetop-3 solenoid valve. Serial connection X=3/8 "G.</p>		

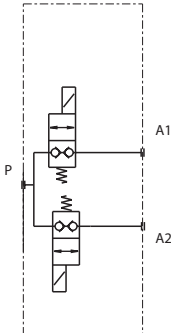
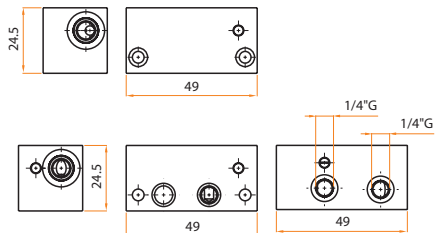
**PIASTRE MODULARI MODULAR PLATES**

Codice Code	Descrizione Description	Schema Scheme	Disegno Drawing
1201PV03040A	<p>Elemento modulare per "lama spartineve". Le due valvole non sono comprese nel blocco.</p> <p>Modular plate "snowplough blade" type. Valves not included.</p>		
1201PV03270A	<p>Base per fissaggio esterno dei moduli HY10. Con uscite da 3/8" G per valvola di massima pressione CPU20.</p> <p>Base for HY10 plate external fixing. 3/8 G outputs for max pressure valve CPU20.</p>		
1201PV03370A	<p>Elemento modulare per valvole di massima.</p> <p>Modular plate for max pressure valve.</p>		
1201PV0017 AT	<p>Con valvola di max in "A".</p> <p>With max pressure valve in "A".</p>		
1201PV0017BT	<p>Con valvola di max in "B".</p> <p>With max pressure valve in "B".</p>		
1201PV0017CT	<p>Con valvola di max in "A" e "B".</p> <p>With max pressure valve in "A" and "B".</p>		
1201PV04490A	<p>Blocco logico per il doppio-semplice effetto. Le due valvole non sono comprese nel blocco.</p> <p>Manifold for double-single acting. Valves are not included.</p>		

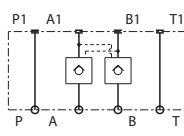
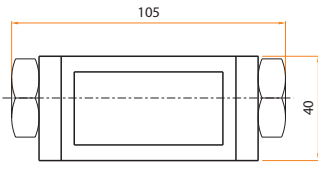
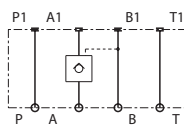
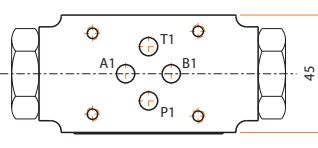
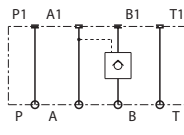
## VALVOLE CETOP-3 CETOP-3 VALVES

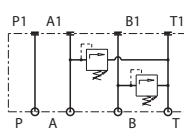
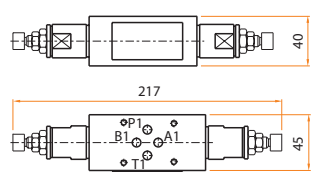
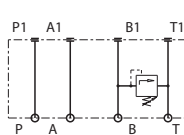
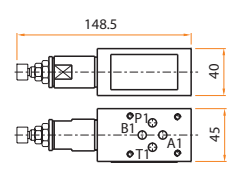
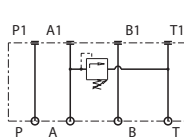
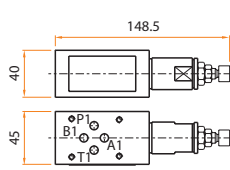
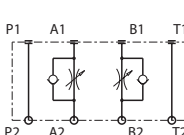
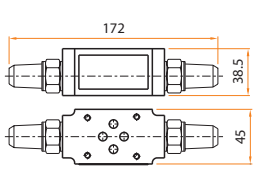
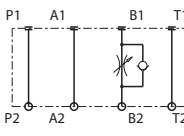
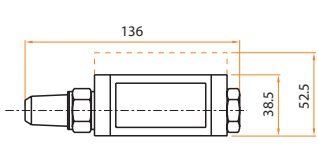
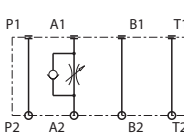
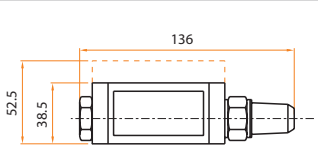
Codice Code	Descrizione Description	Schema Scheme	Disegno Drawing
3224170005EK	T1 - Elemento modulare CETOP-3 con valvole unidirezionali pilotate su "A" e "B". CETOP-3 modular plate with pilot check valve on "A" and "B".		
3224170005AK	Elemento modulare CETOP-3 con valvole unidirezionali pilotate su "A". CETOP-3 modular plate with pilot check valve on "A".		
3224170005BK	Elemento modulare CETOP-3 con valvole unidirezionali pilotate su "B". CETOP-3 modular plate with pilot check valve on "B".		
34A35T23350K	Elemento modulare CETOP-3 con valvole di max in "A" e "B" scarico in "T". CETOP-3 modular plate with valve max pressure on "A" and "B" and drain on "T".		
34A35T40350K	Elemento modulare CETOP-3 con valvole di max in "B" scarico in "T". CETOP-3 modular plate with valve max pressure on "B" and drain on "T".		
34A35T33050K	Elemento modulare CETOP-3 con valvole di max in "A" scarico in "T". CETOP-3 modular plate with valve max pressure on "A" and drain on "T".		
3324170AE22K	Elemento modulare CETOP-3 con regolatori di flusso in "A" e "B". CETOP-3 modular plate with flow regulator on "A" and "B".		
3324170AB22K	Elemento modulare CETOP-3 con regolatori di flusso in "B". CETOP-3 modular plate with flow regulator on "B".		
3324170AA22K	Elemento modulare CETOP-3 con regolatori di flusso in "A". CETOP-3 modular plate with flow regulator on "A".		

## POMPA A MANO HAND PUMP

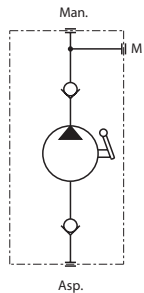
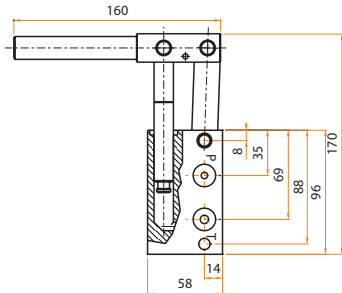
Codice Code	Descrizione Description	Schema Scheme	Disegno Drawing
Pompa manuale Hand pump			
<b>13VZRR00155B</b>	Pompa a mano HY 15 8 cc. Manual pump HY 15 8 cc.		

### Uso del comando di emergenza Emergency control use

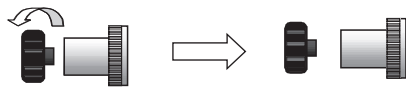

1. Prendere il comando di emergenza in dotazione e svitare il volantino fino ad incontrare resistenza.

Take the emergency manual driving and turn-off till to meet resistance.

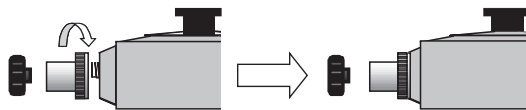

3. Avvitare la ghiera del comando sull'elettrovalvola.  
Turn-on the emergency manual driving on the solenoid valve.

Le operazioni fino al punto quattro sono da intendersi per un movimento, qual'ora si desiderasse effettuare un altro movimento bisogna ripetere le operazioni dal punto 1 al punto 4 per la valvola opposta.

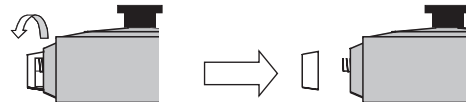

2. Rimuovere, svitandolo, il tappo di protezione dell'elettrovalvola relativo al comando da eseguire.

Remove the protection's plug from solenoid valve related the part to be moved.

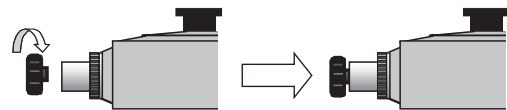

4. Avvitare il volantino fino in fondo (fino ad incontrare resistenza).  
Turn-on the emergency manual driving till to meet resistance.

The operations above described are be intended for one acting. For any other acting repeat the operations from point one to point four on the opposite valve.

1. Infilare la leva a tubo in dotazione sul perno della pompa a mano.  
Filler the hand lever on the hand pump.

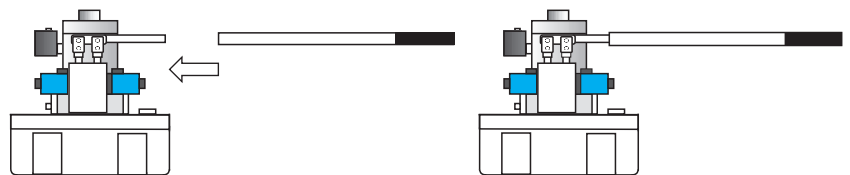

2. Azionare la pompa a mano ed effettuare la movimentazione.  
Act the hand pump for moving.

Nel caso si scaricasse la pompa, eseguire quanto di seguito:  
- aprire i due tappi indicati, ma non toglierli;  
- pompate finché non fuoriesce olio;  
- riavvitare i tappi e a questo punto la pompa è pronta per funzionare.

In the case that air be created inside the pump make the following operations:  
- Turn-off but not remove the plugs as indicated in the photo;  
- Act the hand pump till the oil come out;  
- Turn-on the plugs, and at this time the hand pump is ready to work again.

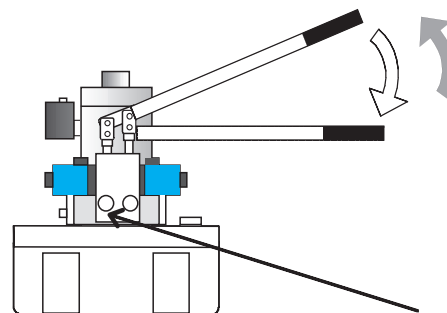

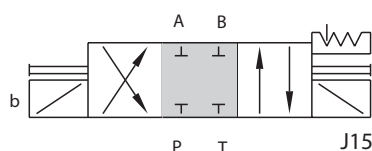
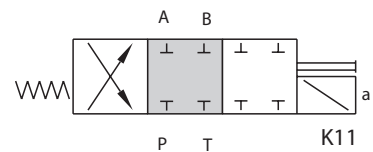
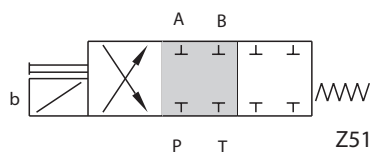
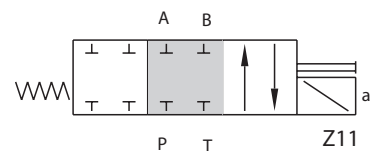
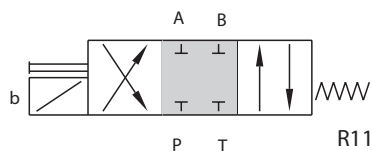
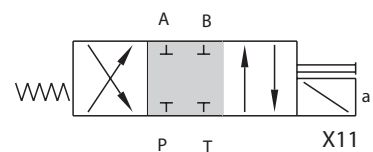
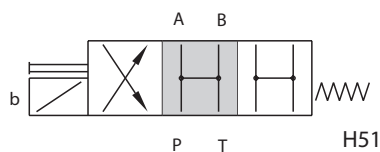
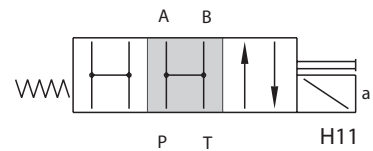
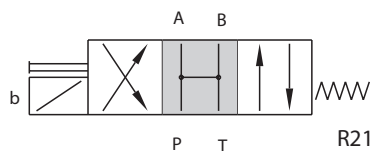
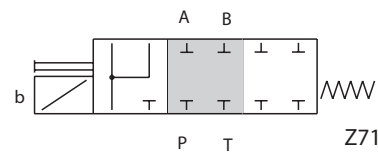
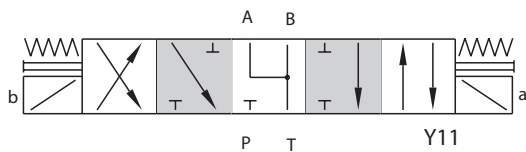
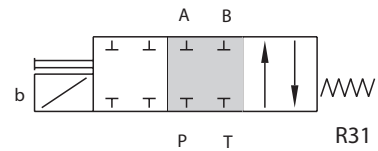
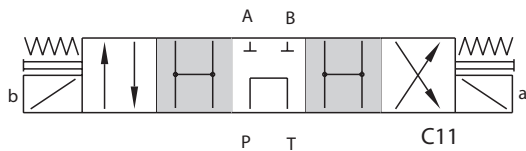
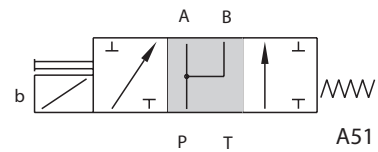
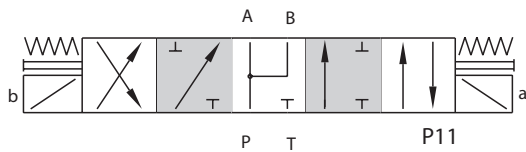
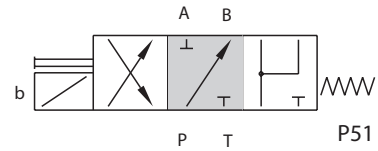
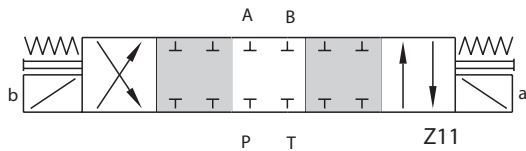
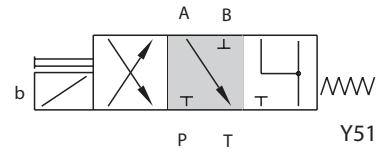
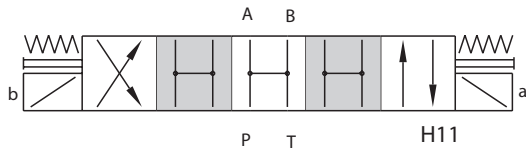

**SCHEMA E TIPOLOGIA ELETTROVALVOLE**
**SOLENOID VALVES TYPE AND SCHEME**

TIPI DI VOLTAGGIO BOBINE	12V DC	24V 50/60 Hz
COIL VOLTAGE	24V DC	110V 50/60 Hz
	48V DC	220V 50/60 Hz

## PIASTRE MODULARI MODULAR PLATES

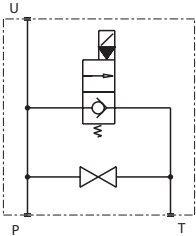
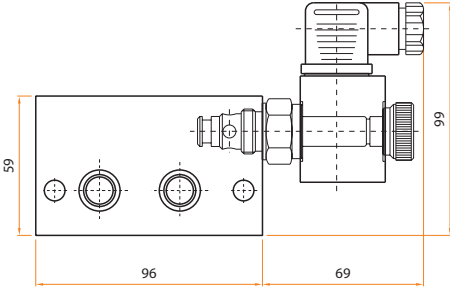
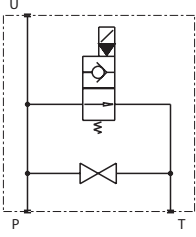
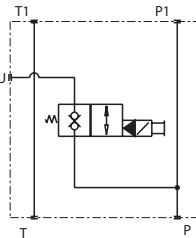
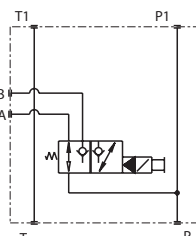
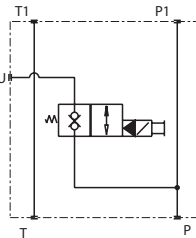
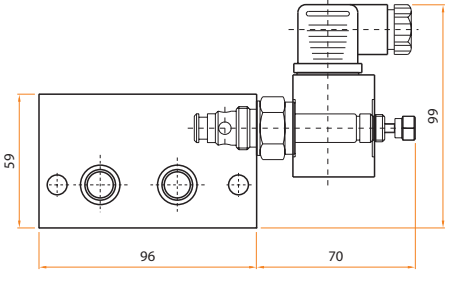
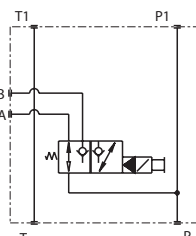
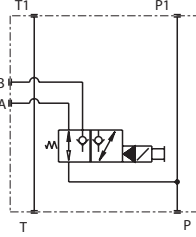
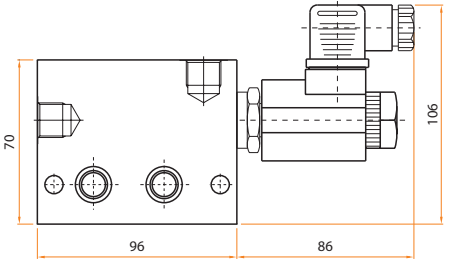
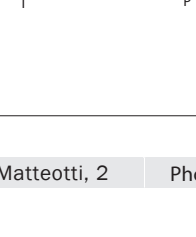
Codice Code	Descrizione Description	Schema Scheme	Disegno Drawing
5628571A178B	Modulo con valvola normalmente chiusa 12V DC. Plate with 12V DC solenoid valve NC.		
5628571B178B	Modulo con valvola normalmente chiusa 24V DC. Plate with 24V DC solenoid valve NC.		
5628572A178B	Modulo con valvola normalmente aperta 12V DC. Plate with 12V DC solenoid valve NO.		
5628572B178B	Modulo con valvola normalmente aperta 24V DC. Plate with 24V DC solenoid valve NO.		
562857CA178B	Modulo con valvola normalmente chiusa a doppia tenuta 12V DC. Plate with 12V DC solenoid valve NC with double retain.		
562857CB178B	Modulo con valvola normalmente chiusa a doppia tenuta 24V DC. Plate with 24V DC solenoid valve NC with double retain.		
562857DA259B	Modulo con valvola normalmente chiusa a tre vie 12V DC. Plate with 12V DC three ways solenoid valve NC.		
562857DB259B	Modulo con valvola normalmente chiusa a tre vie 24V DC. Plate with 24V DC three ways solenoid valve NC.		

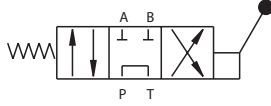
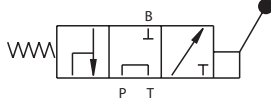
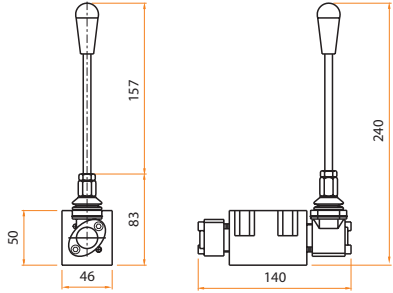
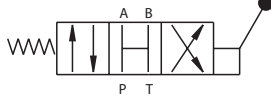
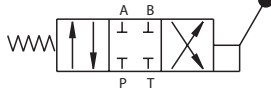
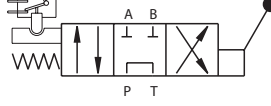
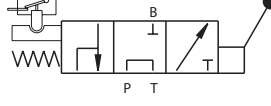
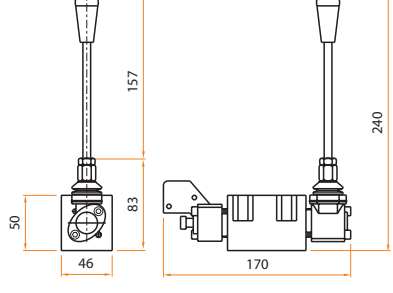
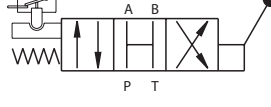
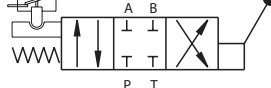

**VALVOLE A COMANDO MANUALE CETOP-3**
**CETOP-3 MANUAL CONTROL VALVES**

Codice Code	Tipo Type	Descrizione Description	Schema Scheme	Disegno Drawing
5629028AA62S	012	Distributore con posizionario. Distributor with positioner.		
5629018FA62S	066	Distributore con posizionario. Distributor with positioner.		
5629028CA62S	011	Distributore con posizionario. Distributor with positioner.		
5629028BA62S	017	Distributore con posizionario. Distributor with positioner.		
5629028AG62S	010	Distributore con micron. Distributor with micron.		
5629018FG62S	009	Distributore con micron. Distributor with micron.		
5629028CG62S	015	Distributore con micron. Distributor with micron.		
5629028BG62S	005	Distributore con micron. Distributor with micron.		

**ELEMENTI APPLICABILI      APPLICABLE ELEMENTS**

Codice Code	Descrizione Description	Disegno Drawing
35Z11110202D	Esclusore manometro diritto <i>Right cutter-out</i>	1
35Z12110202D	Esclusore manometro a 90 ° <i>Cutter-out 90 °</i>	2
1201PA00078D	Tappo cavità valvola <i>Cap for cavity valve</i>	3
56328PA0078A	Tappo premontato con guarnizioni <i>Premounted cap with seals</i>	3
35U54Q2B000A	Minipresa att. manometro <i>Threaded check-coupling on pressure gauge</i>	4
35Z40010202B	Raccordo diritto p/manometro <i>Right joint for pressure gauge</i>	5
1201PA00077D	Tappo di chiusura <i>Closer cap</i>	6
56328PA0077A	Tappo premontato con guarnizioni <i>Premounted cap with seals</i>	6
35U52C2B000A	Minipresa 1/4" <i>Threaded check-coupling 1/4"</i>	7
562571L3005D	Valvola di ritegno x=1/4" <i>Shut-off valve x=1/4"</i>	8
562571L3005C	Valvola di ritegno x=1/8" <i>Shut-off valve x=1/8"</i>	8
1201PA01080D	Tappo chiusura con foro 1/4" <i>Closer cap 1/4"</i>	9
56328PA0108A	Tappo premontato con guarnizioni <i>Premounted cap with seals</i>	9

DIS. 1

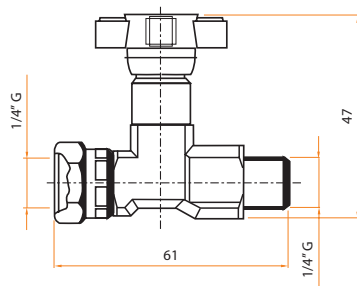

DIS. 2

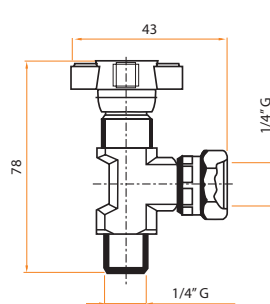

DIS. 3

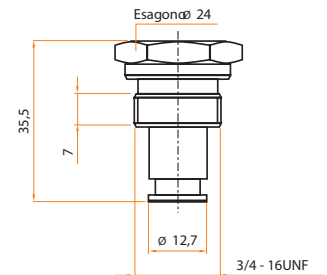

DIS. 4

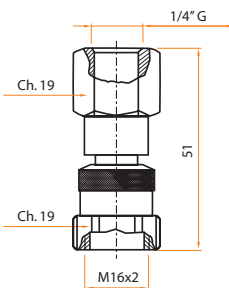

DIS. 5

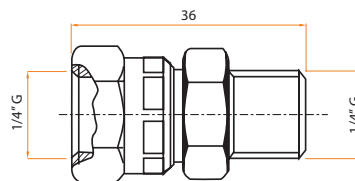

DIS. 6

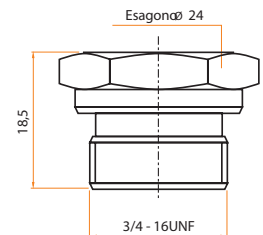

DIS. 7

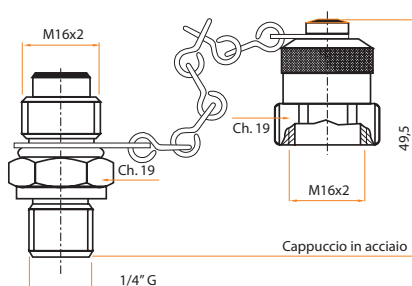

DIS. 8

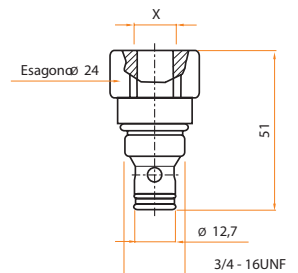

DIS. 9

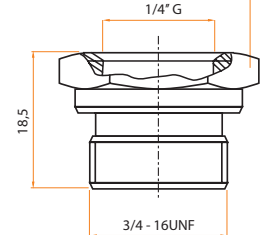

## MANOMETRO AD ATTACCO RADIALE      RADIAL CONNECTION PRESSURE GAUGE

Codice Code	Tipo Type	Scala (Bar)	Disegno Manometri Pressure gauge drawings
-------------	-----------	-------------	---

Manometri in bagno di glicerina, esclusori, miniprese di pressione  
 Pressure gauge ball valves, threaded check-coupling

35BH1210601D	M63RL60	0±60	
35BH1211001D	M63RL100	0±100	
35BH1211601D	M63RL160	0±160	
35BH1212501D	M63RL250	0±250	
35BH1213151D	M63RL315	0±315	
35BH1214001D	M63RL400	0±400	
35BH1216001D	M63RL600	0±600	

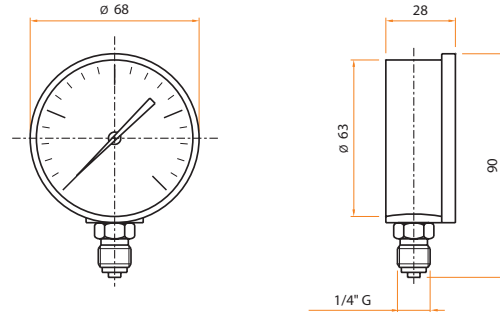

## MANOMETRO AD ATTACCO POSTERIORE      POSTERIOR CONNECTION PRESSURE GAUGE

Codice Code	Tipo Type	Scala (Bar)	Disegno Manometri Pressure gauge drawings
-------------	-----------	-------------	---

Manometri in bagno di glicerina, esclusori, miniprese di pressione  
 Pressure gauge ball valves, threaded check-coupling

35BH1220601D	M63PL60	0±60	
35BH1221001D	M63PL100	0±100	
35BH1221601D	M63PL160	0±160	
35BH1222501D	M63PL250	0±250	
35BH1223151D	M63PL315	0±315	
35BH1224001D	M63PL400	0±400	
35BH1226001D	M63PL600	0±600	

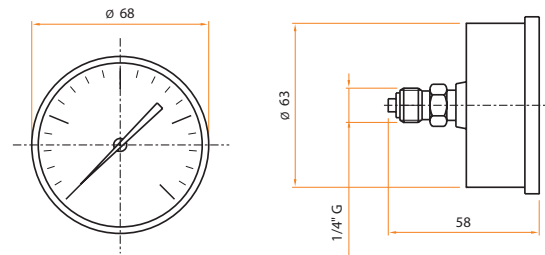

## KIT RADIOCOMANDO PER VEICOLI INDUSTRIALI RADIOCONTROL KIT FOR INDUSTRIAL VEHICLES

