

POMPE AD INGRANAGGI

GEAR PUMPS



Pag.	Page
------	------

CARATTERISTICHE FEATURES		A-3
GAMMA DI PRODOTTO PRODUCT RANGE		A-4
INFORMAZIONI TECNICHE TECHNICAL INFORMATION		A-6
PRESTAZIONI PERFORMANCES		A-10
POMPE GRUPPO PUMPS GROUP	1	A-16
POMPE GRUPPO PUMPS GROUP	2	A-28
POMPE GRUPPO PUMPS GROUP	3	A-52
POMPE GRUPPO PUMPS GROUP	4	A-64

CARATTERISTICHE

La Galtech è specializzata nella produzione di pompe dal gruppo 1 al gruppo 4 suddivise in 34 cilindrate da 0,9 a 120 cc/g, e fino a 320 bar di pressione massima di esercizio.

Sono disponibili versioni con flange e coperchi in ghisa per ridurre il livello di rumorosità.

Il bilanciamento idrostatico è a ripresa del gioco assiale mediante pressione inviata ad un'area definita della boccola.

La lubrificazione dei supporti è automatica e proporzionale alla pressione di impiego della pompa.

Ogni pompa può essere assemblata con totale intercambiabilità sia con flange standard (europea, tedesca, SAE) sia con quelle speciali (ZF, Perkins, Renault) e con alberi conici, cilindrici e scanalati.

E' possibile inoltre montare coperchi con valvole limitatrici di pressione e valvole regolatrici di flusso.

Tutte le pompe sono predisposte per il traino posteriore di una o più pompe interponendo il kit di accoppiamento disponibile anche in versione corta.

FEATURES

Galtech is specialized in pumps production from group 1 to group 4, divided into 34 displacements: from 0,9 to 120 cc/rev, and up to 320 bar of max working pressure.

Pumps are available with cast iron flanges and covers version to reduce the loudness level.

Hydrostatic balance takes up axial slack through the pressure supplied to a defined bushing area.

Bearings lubrication is automatic and proportional to the pump operating pressure.

Each pump can be assembled whether with standard flanges (european, german or SAE) or with special ones (ZF, Perkins and Renault), with tapered, cylindrical or splined shafts.

Furthermore it is possible to assemble covers with pressure relief valves and flow control valves.

All standard pumps are arranged to drive a supplementary pumps, using the coupling kits, available also in the short version.



GAMMA DI PRODOTTO

PRODUCT RANGE

POMPE GRUPPO
PUMPS GROUP **1**

Standard

SAE AA

MC 32

E 32 BX

E 32 CX

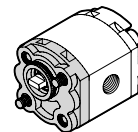
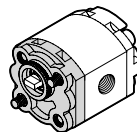
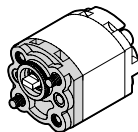
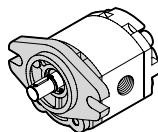
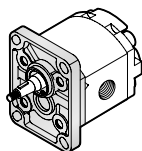

A-16

A-18

A-20

A-22

A-24

Grandezza Size	Cilindrata Displacement	Velocità max. Max. speed	Portata max. Max. flow	Velocità min. Min. speed	Portata min. Min. flow	Rendimento volumetrico min. Min. volumetric efficiency %
	[cm ³ /g] - (in ³ /rev)	[g/min] - (rpm)	[l/min] - (Gal/min)	[g/min] - (rpm)	[l/min] - (Gal/min)	
1SPA_0.9	0.89 (0.05)	6000	5.3 (1.40)	600	0.49 (0.13)	92*
1SPA_1.2	1.18 (0.07)	6000	7.1 (1.88)	600	0.65 (0.17)	
1SPA_1.6	1.6 (0.10)	6000	9.6 (2.54)	400	0.61 (0.16)	
1SPA_2.0	2.0 (0.12)	5500	11 (2.91)	400	0.76 (0.20)	95*
1SPA_2.5	2.5 (0.15)	5000	12.5 (3.30)	400	0.95 (0.25)	
1SPA_3.2	3.2 (0.20)	4500	14.4 (3.80)	400	1.21 (0.32)	
1SPA_3.7	3.7 (0.23)	4000	14.8 (3.91)	400	1.40 (0.37)	
1SPA_4.2	4.2 (0.26)	3500	14.7 (3.88)	400	1.60 (0.42)	
1SPA_5.0	5.0 (0.31)	3000	15 (3.96)	400	1.90 (0.50)	
1SPA_6.3	6.3 (0.38)	2700	17 (4.49)	400	2.39 (0.63)	
1SPA_7.8	7.76 (0.47)	2500	19.4 (5.13)	400	2.95 (0.78)	
1SPA_9.8	9.78 (0.60)	2000	19.6 (5.18)	400	3.71 (0.98)	

* (Valori rilevati in fase di collaudo a 1500 giri/min / Value collected during the testing at 1500 rpm)

POMPE GRUPPO
PUMPS GROUP **2**

Standard

SAE A

SAE A-OR

B80 C

B50 C

E52 C

PRKS 400D

SAE A 14*

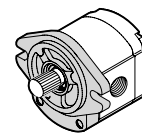
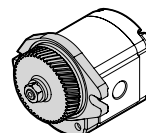
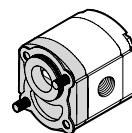
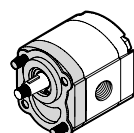
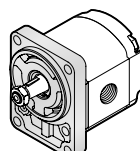
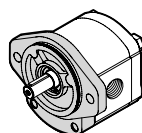
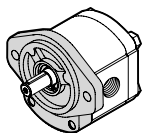
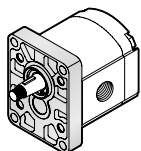

A-28

A-30

A-32

A-34

A-32

A-34

A-36

A-38

A-40

A-42

A-44

Grandezza Size	Cilindrata Displacement	Velocità max. Max. speed	Portata max. Max. flow	Velocità min. Min. speed	Portata min. Min. flow	Rendimento volumetrico min. Min. volumetric efficiency %
	[cm ³ /g] - (in ³ /rev)	[g/min] - (rpm)[rpm]	[l/min] - (Gal/min)	[g/min] - (rpm)	[l/min] - (Gal/min)	
2SP_4	4 (0.24)	4000	16 (4.23)	500	1.9 (0.50)	95*
2SP_6	6 (0.37)	4000	24 (6.34)	500	2.85 (0.75)	
2SP_8	8.5 (0.52)	3500	29.7 (7.85)	500	4.03 (1.06)	
2SP_11	11 (0.67)	3500	38.5 (10.17)	500	5.22 (1.38)	
2SP_14	14 (0.85)	3500	49 (12.95)	500	6.65 (1.76)	
2SP_16	16.5 (1.01)	3500	57.7 (15.24)	500	7.83 (2.07)	
2SP_19	19.5 (1.19)	3300	64.3 (16.99)	500	9.26 (2.45)	
2SP_22	22.5 (1.37)	2800	63 (16.64)	500	10.68 (2.82)	
2SP_26	26 (1.59)	2500	65 (17.17)	500	12.35 (3.26)	

* (Valori rilevati in fase di collaudo a 1500 giri/min / Value taken during the testing at 1500 rpm)

GAMMA DI PRODOTTO

PRODUCT RANGE

POMPE GRUPPO
PUMPS GROUP

3

Standard

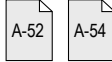
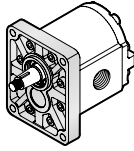

SAE B

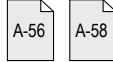
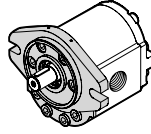

SAE B-OR

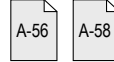
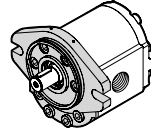

ZFC

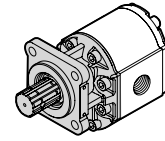

Grandezza Size	Cilindrata Displacement	Velocità max. Max. speed	Portata max. Max. flow	Velocità min. Min. speed	Portata min. Min. flow	Rendimento volumetrico min. Min. volumetric efficiency %
	[cm ³ /g] - (in ³ /rev)	[g/min] - (rpm)	[lt/min] - (Gal/min)	[g/min] - (rpm)	[lt/min] - (Gal/min)	
3SP_19	19 (1.16)	3500	66.5 (17.57)	700	12.64 (3.34)	95*
3SP_22	22.3 (1.36)	3500	78 (20.61)	700	14.83 (3.92)	
3SP_29	29.3 (1.79)	3300	96.7 (25.55)	700	19.48 (5.15)	
3SP_33	32.9 (2.01)	3300	108.6 (28.69)	700	21.88 (5.78)	
3SP_36	36.4 (2.22)	3300	120.1 (31.73)	700	24.21 (6.40)	
3SP_44	43.5 (2.65)	3000	130.5 (34.48)	700	28.93 (7.64)	
3SP_52	51.7 (3.15)	3000	155.1 (40.98)	700	34.38 (9.08)	
3SP_62	61.1 (3.73)	2500	152.7 (40.34)	700	40.63 (10.73)	

* (Valori rilevati in fase di collaudo a 1500 giri/min / Value taken during the testing at 1500 rpm)

POMPE GRUPPO
PUMPS GROUP

4

Standard

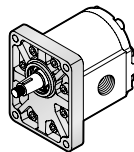

Grandezza Size	Cilindrata Displacement	Velocità max. Max. speed	Portata max. Max. flow	Velocità min. Min. speed	Portata min. Min. flow	Rendimento volumetrico min. Min. volumetric efficiency %
	[cm ³ /g] - (in ³ /rev)	[g/min] - (rpm)	[lt/min] - (Gal/min)	[g/min] - (rpm)	[lt/min] - (Gal/min)	
4SP G60	60.3 (3.68)	2300	138.7 (36.64)	800	45.82 (12.11)	92*
4SP G70	69 (4.21)	2200	151.8 (40.11)	800	52.44 (13.85)	
4SP G86	86 (5.25)	2200	189.2 (49.99)	800	65.36 (17.27)	
4SP G103	103 (6.29)	2000	206 (54.43)	800	78.28 (20.68)	
4SP G120	120 (7.32)	2000	240 (63.41)	800	91.2 (24.10)	

* (Valori rilevati in fase di collaudo a 1500 giri/min / Value collected during the testing at 1500 rpm)

INFORMAZIONI TECNICHE

TECHNICAL INFORMATION

Definizione delle pressioni

Le pompe possono essere sottoposte alle pressioni P1, P2, P3 indicate nelle tabelle delle prestazioni. Il grafico seguente ne illustra le definizioni e l'applicabilità rispettando i limiti delle velocità di rotazione riportati.

Definition of pressures

The pumps can be subjected to the pressures P1, P2 or P3 indicated in the performance tables. The following diagram illustrates the definitions and applicability of these, compared to the rotation speed limits included.

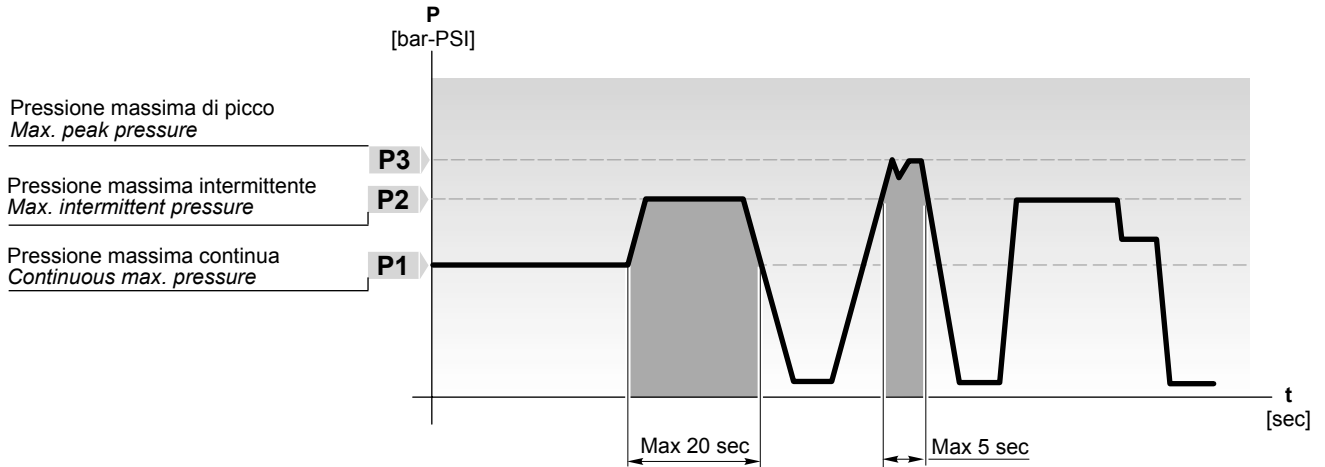

Misure idrauliche
Hydraulic measures

Q	Portata <i>Flow</i>	[l/min - Gal/min]
M	Coppia <i>Torque</i>	[Nm - lbf.in]
P	Potenza <i>Power</i>	[kW - HP]
V	Cilindrata <i>Displacement</i>	[cm ³ /rev - in ³ /rev]
N	Velocità <i>Speed</i>	[min ⁻¹ - rpm]
Δp	Pressione <i>Pressure</i>	[bar - PSI]
η_v	Rendimento volumetrico <i>Volumetric efficiency</i>	
η_m	Rendimento meccanico <i>Mechanical efficiency</i>	
η_t	Rendimento totale <i>Overall efficiency</i>	

Formule utili
Useful formulas

$$Q = V \text{ [cm}^3\text{/rev]} \times \eta_v \times n \times 10^{-3} \text{ l/min}$$

$$M = \frac{\Delta p \text{ [bar]} \times V \text{ [cm}^3\text{/rev]}}{62.83 \times \eta_m} \text{ Nm}$$

$$P = \frac{\Delta p \text{ [bar]} \times V \text{ [cm}^3\text{/rev]} \times n}{600 \times 1000 \times \eta_t} \text{ kW}$$

Fattore di conversione
Conversion factors

1 l/min = 0.2641 US Gal/min
1 Nm = 8.851 lbf.in
1 N = 0.2248 lbs
1kW = 1.34 HP
1cm ³ /giro = 0.061 in ³ /rev
1 bar = 14,5 PSI
1 mm = 0,0394 in
1 kg = 2.205 lb

INFORMAZIONI TECNICHE

TECHNICAL INFORMATION

Perdita di carico

Il nomogramma seguente permette di valutare la perdita di carico per ogni 100 m di tubazione conoscendo la viscosità dell'olio, la portata della pompa e il diametro della condotta. Sulle rispettive scale, si fissano i valori della viscosità (V), della portata (Q) e del diametro (D); si traccia una retta che congiunge i due punti V e Q; dove questa interseca la linea indice viene definito il punto I. Prolungando la retta che congiunge il punto I al punto D, all'intersezione con l'ultima scala si leggerà il valore della perdita di carico.

Pressure drops

The following nomogram allows you to calculate the pressure drops for each 100 m of piping when the viscosity of the oil, the delivery capacity of the pump and the diameter of the piping are known. The viscosity (V), flow capacity (Q) and diameter (D) values are fixed on the respective scales; a line is drawn joining the points V and Q; the point where this intersects the index line is defined as point I. If the line joining point I to point D is extended, the load pressure drops value can then be read at the intersection with the last scale.

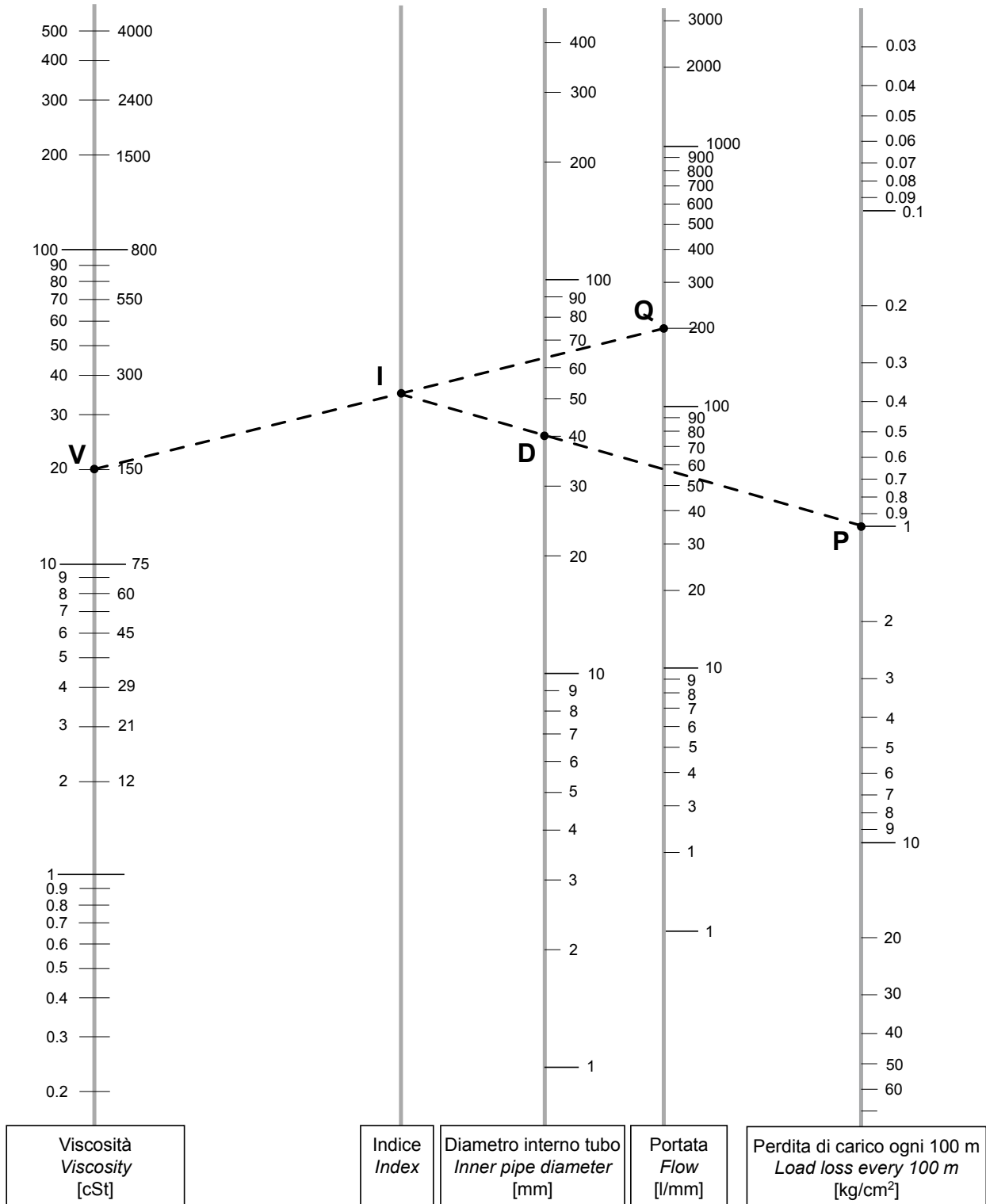

INFORMAZIONI TECNICHE

Fluidi idraulici

È consigliabile utilizzare oli idraulici di origine minerale con caratteristiche antischiuma, antiossidante, anticorrosione e con elevato indice di viscosità;

- Viscosità raccomandata 15 ÷ 92 mm² /s
- Viscosità limite d'avviamento 3000 mm² /s

Durante il normale funzionamento la temperatura dell'olio dovrà essere compresa fra 20°C e 65°C con valori limite compresi fra -15°C e 80°C.

Pressione in aspirazione

La pressione di esercizio in alimentazione ammessa deve essere compresa nell'intervallo 0.7 - 3 bar (assoluti).

Per valori superiori (fino a 30 bar) è necessario ricorrere alle versioni dotate di guarnizione K.

Condotti di aspirazione e mandata

Particolare attenzione dovrà essere posta nel dimensionamento delle tubazioni (rigide o flessibili) evitando lunghezze sproporzionate, improvvise variazioni di sezione, piccoli raggi di curvatura scegliendo comunque sezioni dei condotti che garantiscano una velocità dell'olio compresa fra 0.6 e 12 m/s.

Filtrazione

Per eliminare eventuali impurità presenti nell'olio e garantire una durata superiore alla pompa, è necessario introdurre nell'impianto un'efficace filtrazione verificandone periodicamente la funzionalità.

I livelli di filtrazione raccomandati sono i seguenti:

- 26/23 ISO DIS 4406 fino a 150 bar
- 23/20 ISO DIS 4406 per pressioni superiori.

Note per l'installazione

- Assicurarsi che il giunto utilizzato per il trascinamento compensi eventuali disallineamenti assiali che potrebbero pregiudicare l'integrità della pompa.
- Nel caso in cui siano presenti dei carichi radiali e/o assiali sull'albero della pompa (come ad esempio quando il trascinamento viene effettuato tramite pulegge e cinghie) è necessario optare per le versioni disponibili con supporto rinforzato.
- Il giunto di collegamento fra alberi scanalati dovrà essere opportunamente lubrificato, libero di muoversi assialmente e di lunghezza adatta a coprire tutta l'estensione dei due alberi (motore e pompa).
- Se la pompa è sottoposta a verniciatura, proteggere l'anello di tenuta verificando anche che la zona di contatto fra anello di tenuta e albero sia priva di polvere o di sedimenti abrasivi.

Senso di rotazione

Il senso di rotazione viene definito S (sinistro) e D (destro) osservando l'albero frontalmente.

Le pompe sono monodirezionali per cui in fase di ordine è necessario precisare il senso di rotazione desiderato, oppure intervenire modificando l'assetto interno come illustrato di seguito (inversione del senso di rotazione).

Nelle pagine con le caratteristiche delle pompe sono evidenziate le direzioni dei flussi di mandata e aspirazione per ogni versione e per senso di rotazione.

TECHNICAL INFORMATION

Hydraulic fluids

It is advisable to use hydraulic oils of mineral origin with anti-foaming, anti-oxidant and anti-corrosion characteristics and a high viscosity index;

- Recommended viscosity 15 ÷ 92 mm² /s (cSt)
- Start-up viscosity limit 3000 mm² /s (cSt)

During normal operation, the temperature of the oil must be between 20°C and 65°C and limit values between -15°C and 80°C.

Suction pressure

The allowed working pressure supplied must be in the range 0.7 - 3 bar (absolute).

For higher values (up to 30 bar), versions with a K seal must be used.

Suction and delivery pipes

Particular attention must be given to the sizing of pipes (rigid or flexible), avoiding disproportionate lengths, sudden variations in cross section or small curvature radius, in any case selecting pipe cross-sections that guarantee an oil speed between 0.6 and 12 m/s.

Filtration

In order to eliminate any impurities present in the oil and to guarantee a longer duration of the pump, the system must be equipped with effective filtration which must be periodically checked to ensure that it is operating correctly.

The following are the recommended filtration levels:

- 26/23 ISO DIS 4406 up to 150 bar
- 23/20 ISO DIS 4406 for higher pressures.

Installation notes

- Make sure that the coupling used for pulling compensates for any axial misalignments that could compromise the integrity of the pump.
- If there are radial and/or axial loads on the pump shaft (as is the case, for example, when pulling is carried out using pulleys and belts) the versions available with a support must be chosen.
- The connection coupling between spline shafts must be appropriately lubricated, free to move axially and of an adequate length to cover the entire extension of the two shafts (motor and pump).
- If the pump is painted, protect the shaft seal and also make sure that the contact zone between the shaft seal and the shaft is free of dust or abrasive sediments.

Rotation direction

The rotation direction is defined as S (left/anticlockwise) or D (right/clockwise) by observing the shaft from the front.

The pumps are monodirectional and therefore when ordering the required rotation direction must be specified; alternatively it is possible to modify the internal set-up as illustrated below (inversion of the rotation direction).

The pages regarding the pump characteristics highlight the directions of the delivery and suction flows for each version and rotation direction.

INFORMAZIONI TECNICHE

TECHNICAL INFORMATION

Inversione del senso di rotazione

Wise rotation reversal

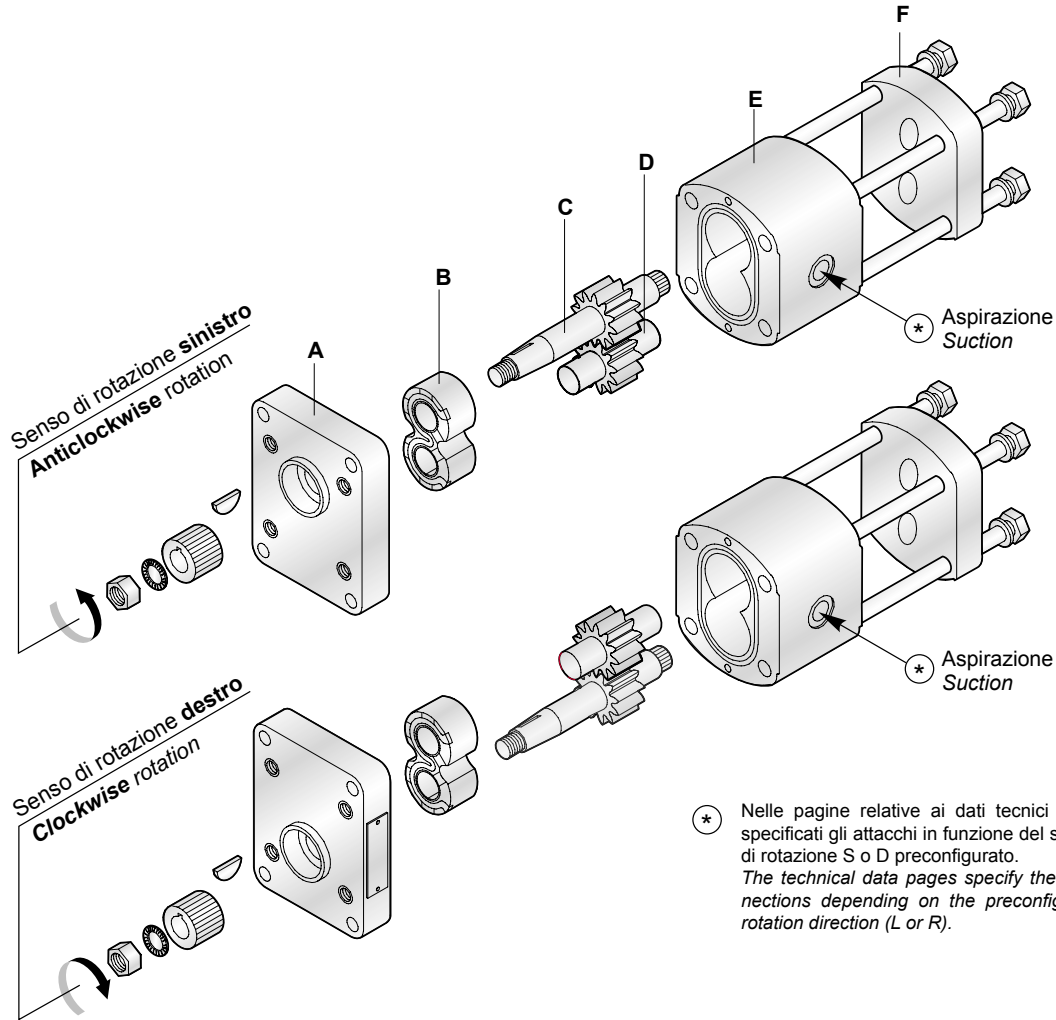

Fig. 1

Fig. 2

* Nelle pagine relative ai dati tecnici sono specificati gli attacchi in funzione del senso di rotazione S o D preconfigurato.
The technical data pages specify the connections depending on the preconfigured rotation direction (L or R).

Il senso di rotazione delle pompe è evidenziato da una freccia sulla targhetta.

L'inversione del senso di rotazione di una pompa si esegue nel seguente modo:

- Smontare la pompa come da figura 1.
- Sfilare gli ingranaggi C e D e rimontarli secondo la figura 2.
- Rimontare la boccia B nella stessa posizione della figura 1.
- Capovolgere la flangia A e rimontare la pompa serrando le viti con una chiave dinamometrica.
- Per le pompe GR3 - GR4, smontare solo la flangia anteriore.

Pumps wise rotation is indicated by an arrow on the label.

How to invert the pump wise rotation:

- Disassemble pump as shown in figure 1.
- Pull off gears C - D and reassemble according to figure 2.
- Reassemble bushing B as before.
- Reverse the flange A and reassemble the pump tightening the screws by dynamometric wrench.
- For the pumps GR3 - GR4, disassemble only front flange..

Tipo di pompa Type of pump	GR1	GR2	GR3	GR4
Numero di viti Numbers of screws	4	4	16	16
Tipo di filetto Type of threads	M8	M10	M10	M14
Coppia di serraggio viti Tightening torque of screws	30 Nm (266 in-lbs)	50 Nm (443 in-lbs)	60 Nm (531 in-lbs)	140 Nm (1239 in-lbs)
Tipo di giunto Type of coupling	1IS 12M	2IS 14M 2IS 15M	3IS 18M	4IS 23M
Coppia di serraggio dado giunto Tightening torque at nut coupling	9 ÷ 10 Nm (80 ÷ 89 in-lbs)	22 ÷ 25 Nm (195 ÷ 221 in-lbs) 32 ÷ 35 Nm (283 ÷ 310 in-lbs)	50 ÷ 55 Nm (443 ÷ 487 in-lbs)	100 ÷ 120 Nm (885 ÷ 1062 in-lbs)

PRESTAZIONI

PERFORMANCES

POMPE GRUPPO
PUMPS GROUP

1

PRESTAZIONI

Diagramma Portata - Velocità di rotazione
Flow - Speed chart

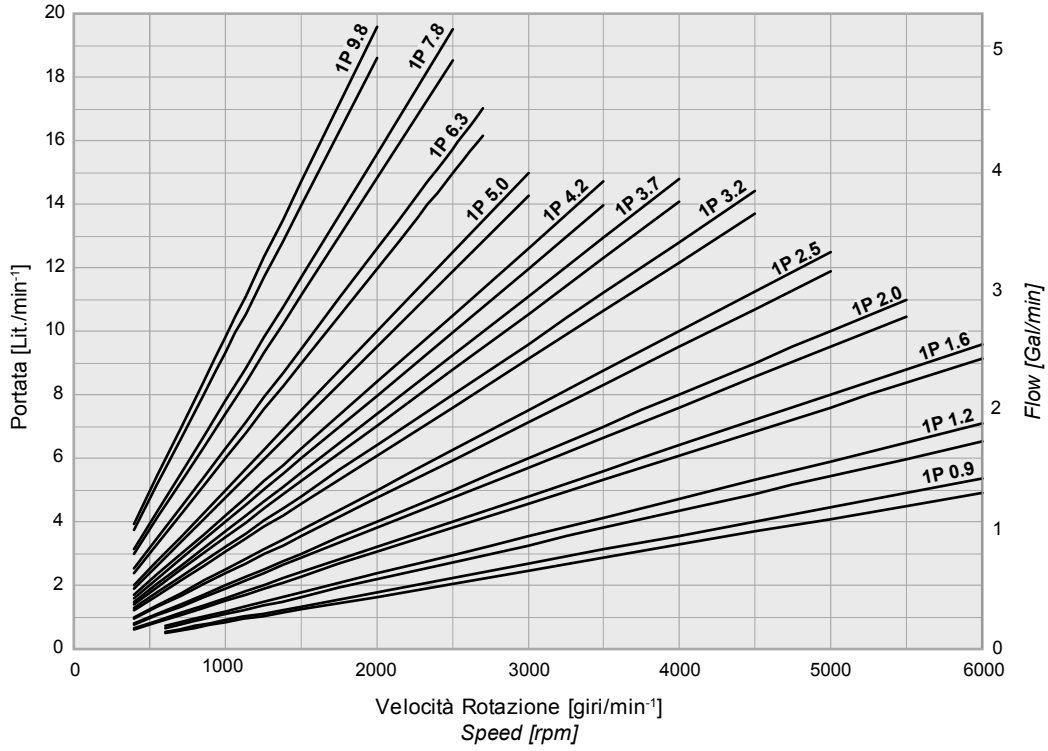

Pompe Gruppo 1 Diagrammi Potenze - n°/giri / Pumps group 1 Diagrams Power- n°Rev

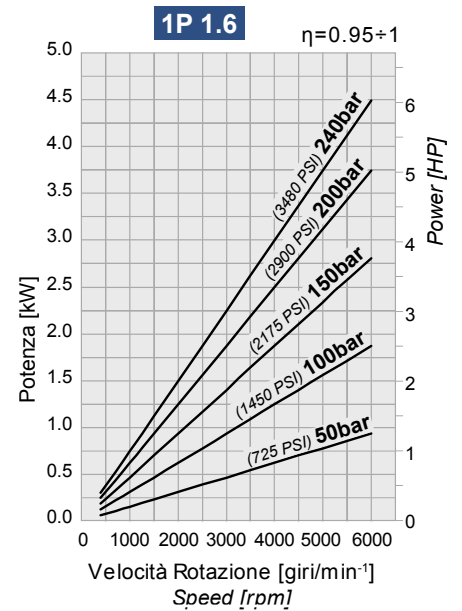
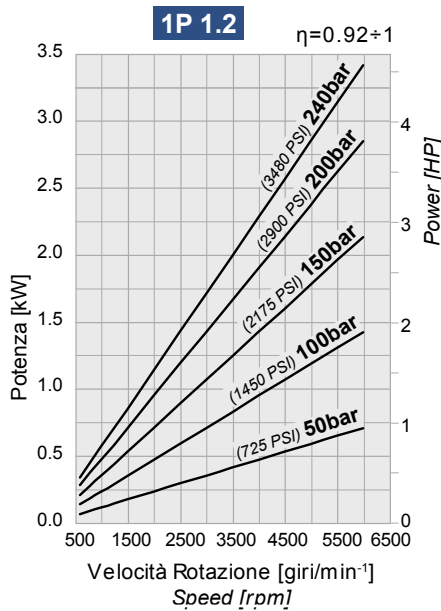
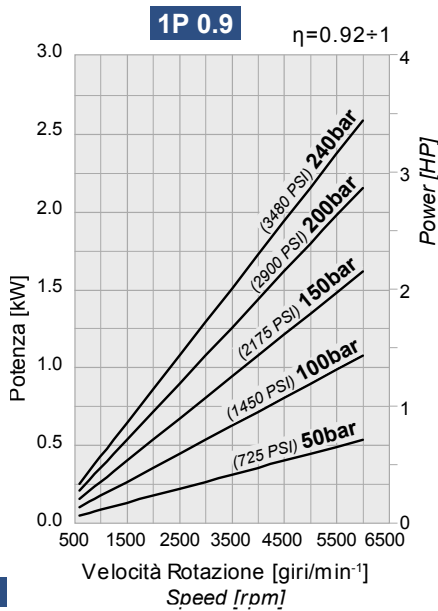



Diagramma Portata - Velocità di rotazione
Flow - Speed chart



Pompe Gruppo 2 Diagrammi Potenze - n°/giri / Pumps group 1 Diagrams Power- n°Rev



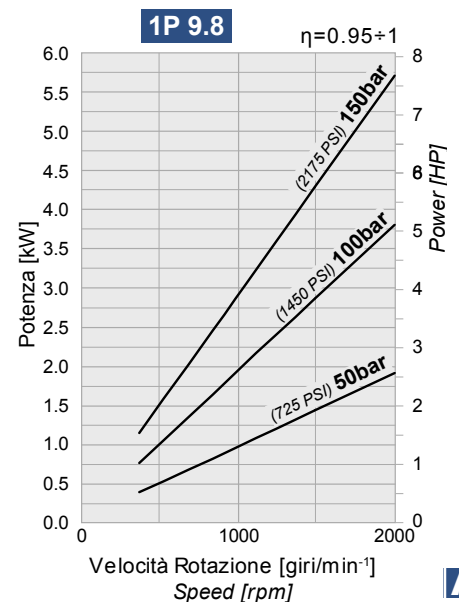
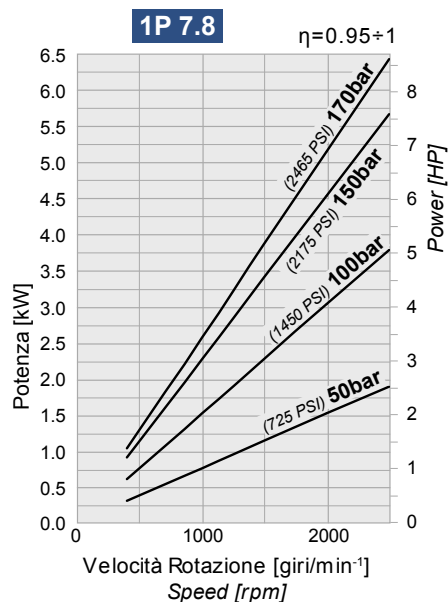
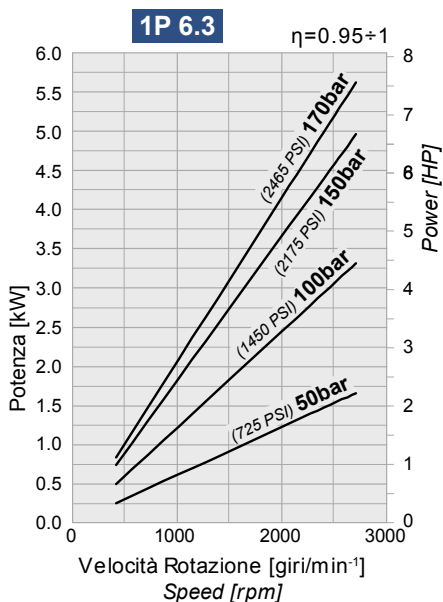
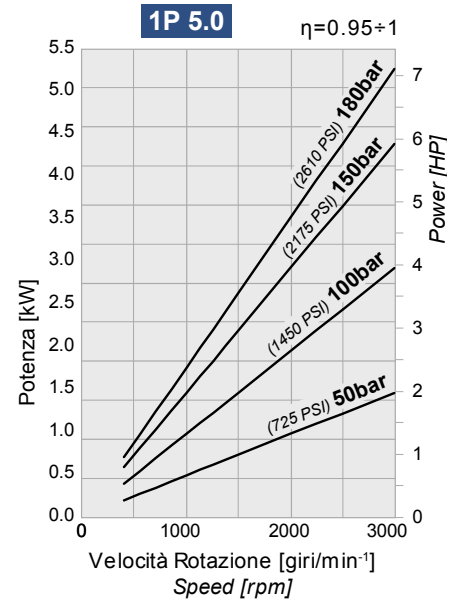
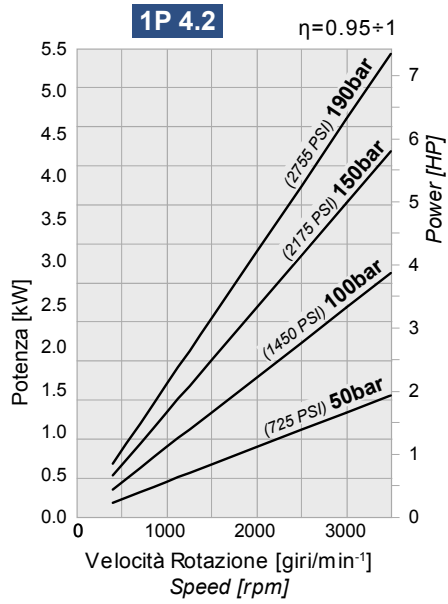
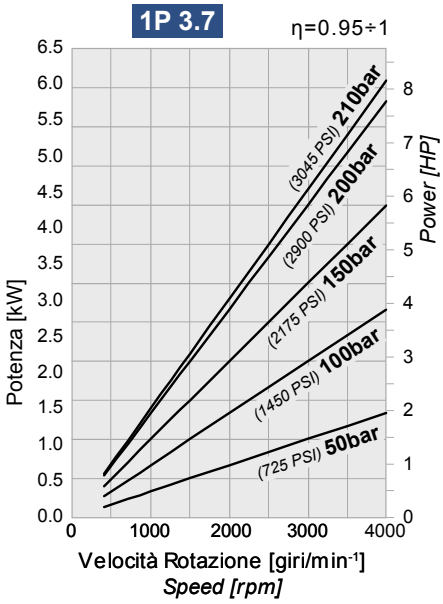
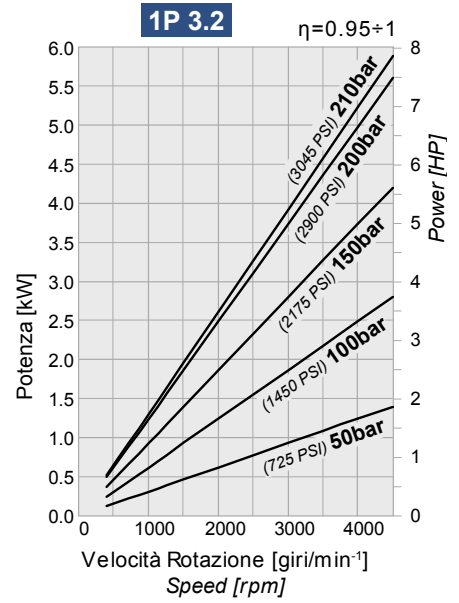
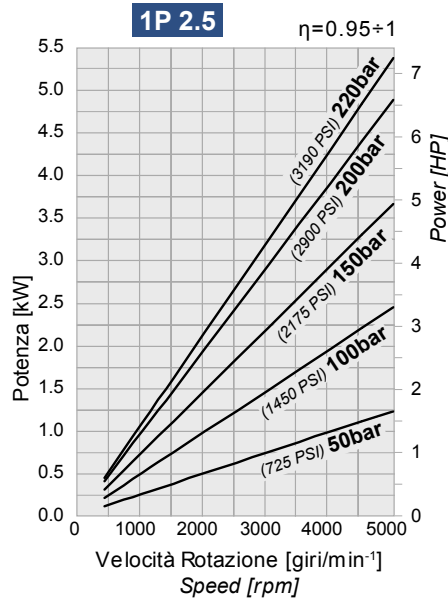
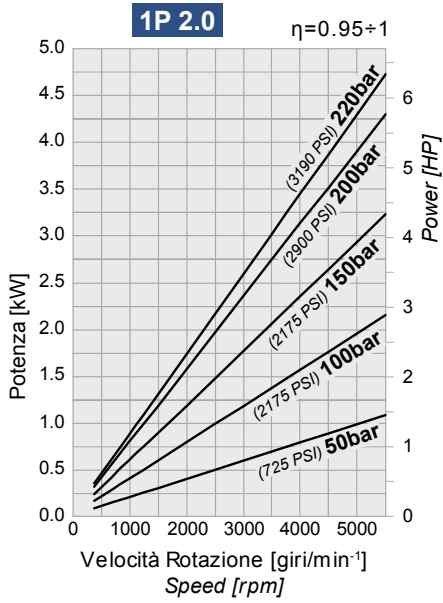
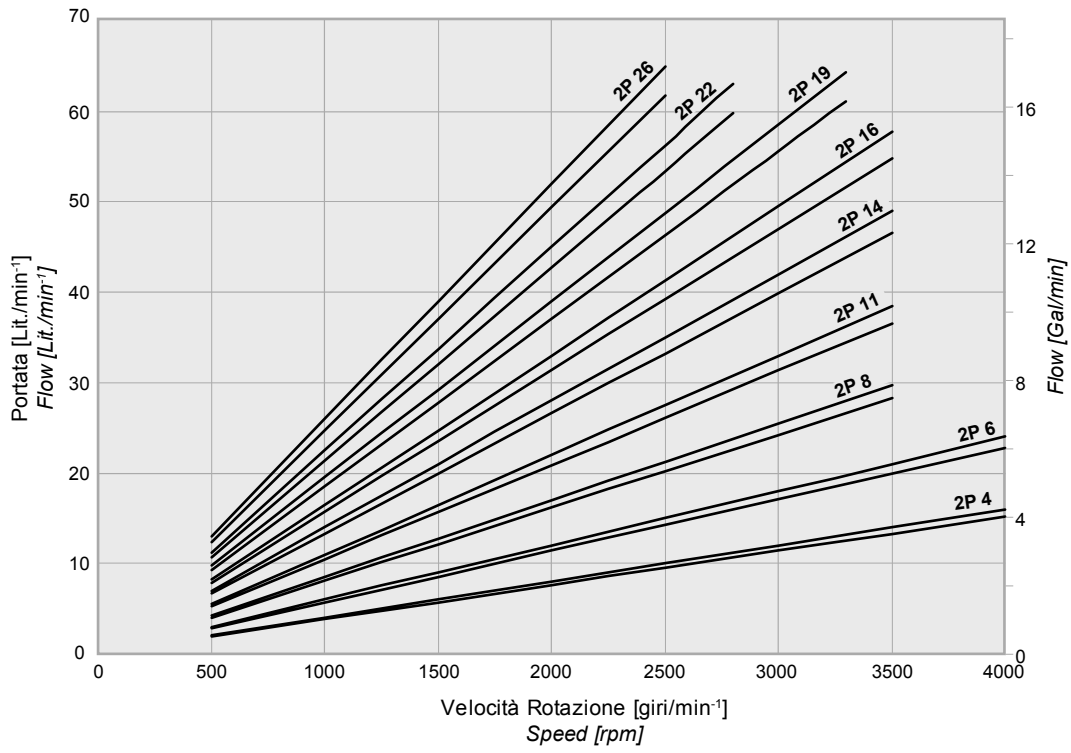
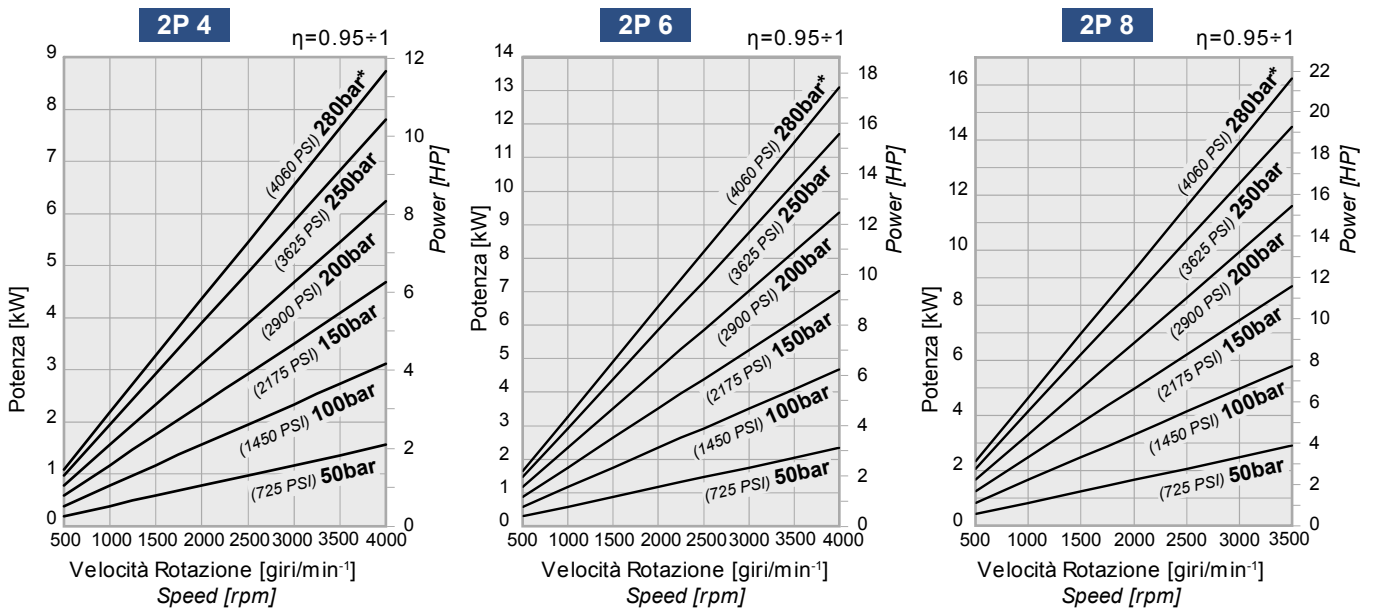
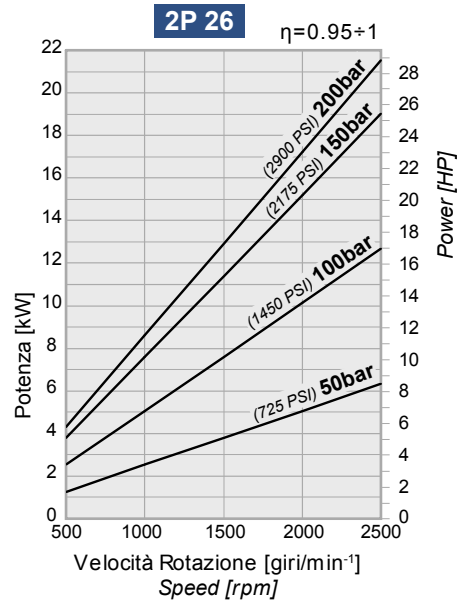
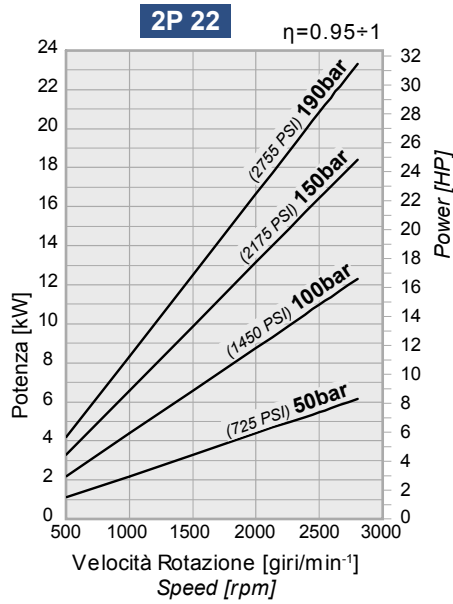
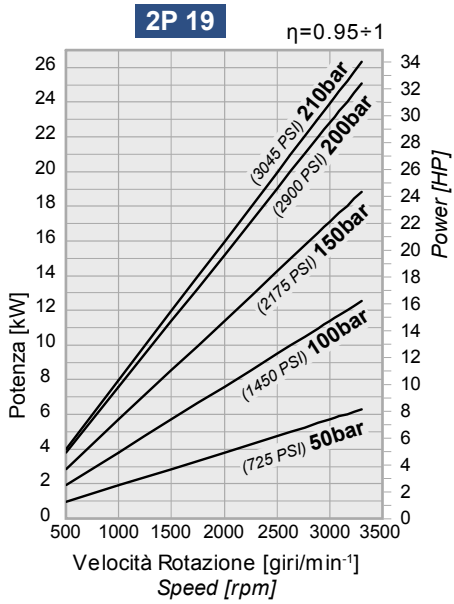
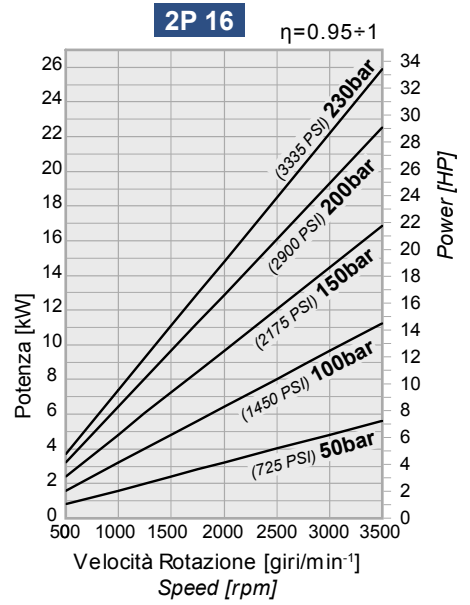
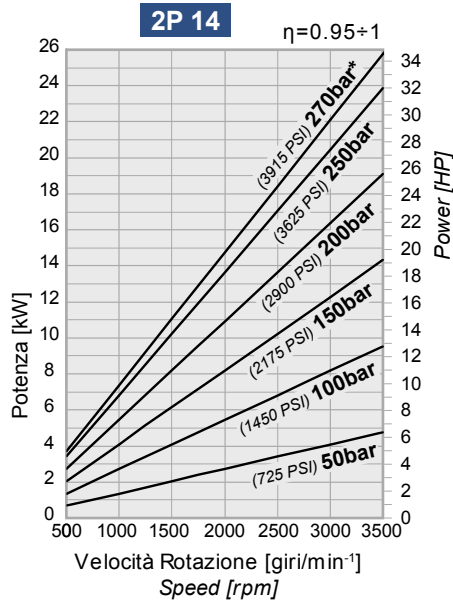
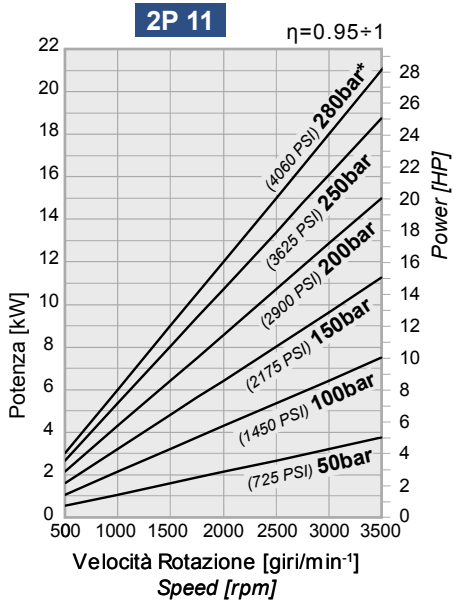

* Solo pompe in ghisa / Only for cast iron pumps

Diagramma Portata - Velocità di rotazione
Flow - Speed chart

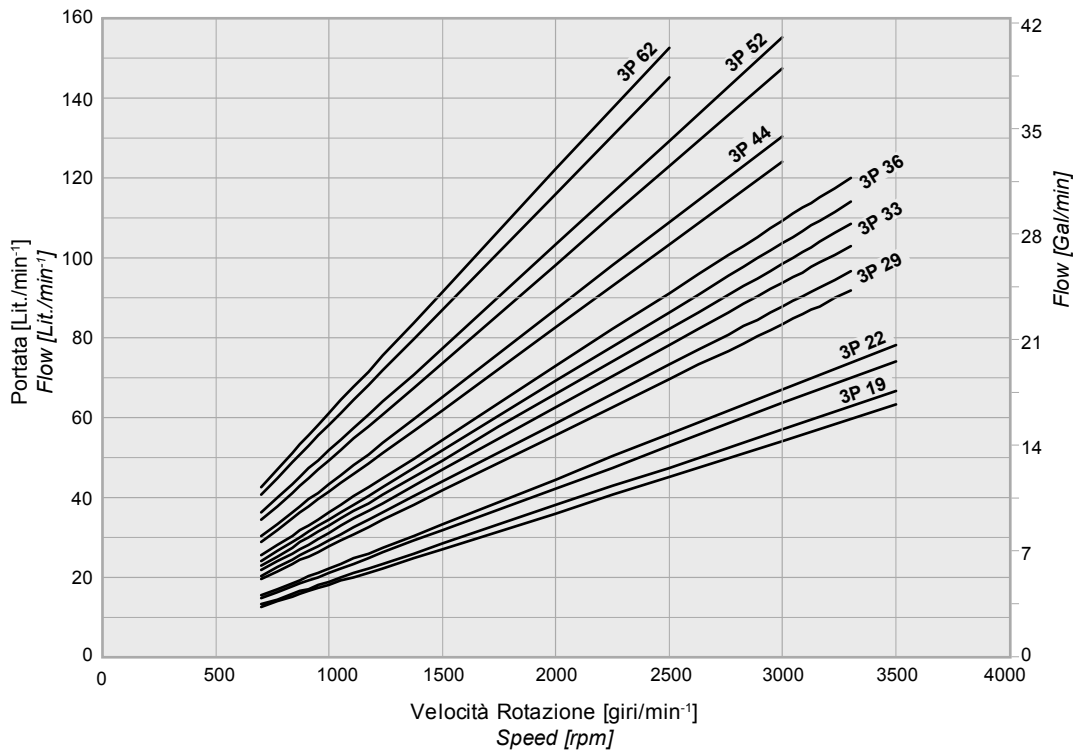

Pompe Gruppo 3 Diagrammi Potenze - n°/giri / Pumps group 1 Diagrams Power- n°Rev

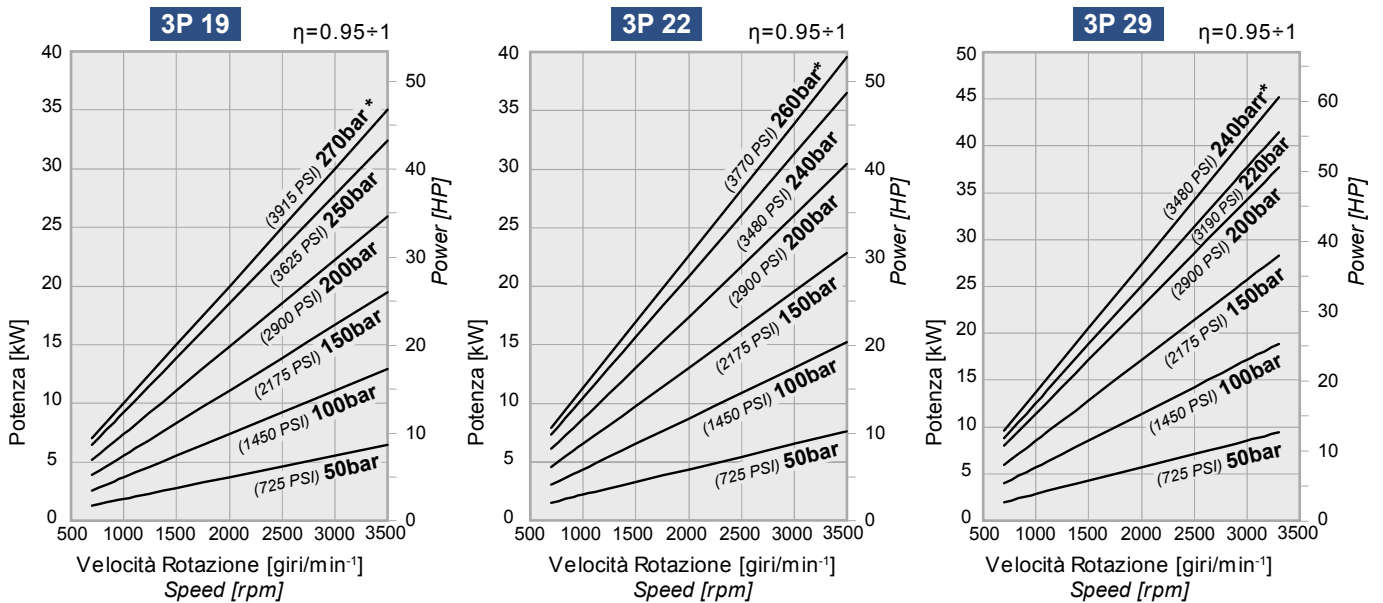

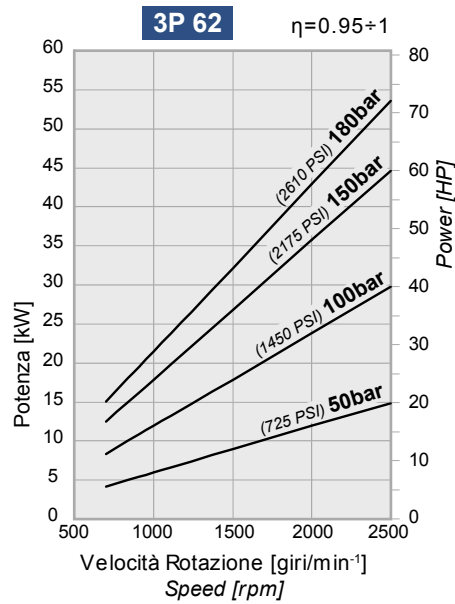
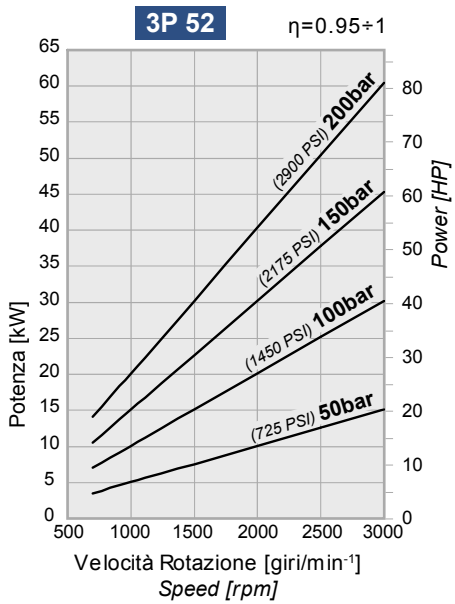
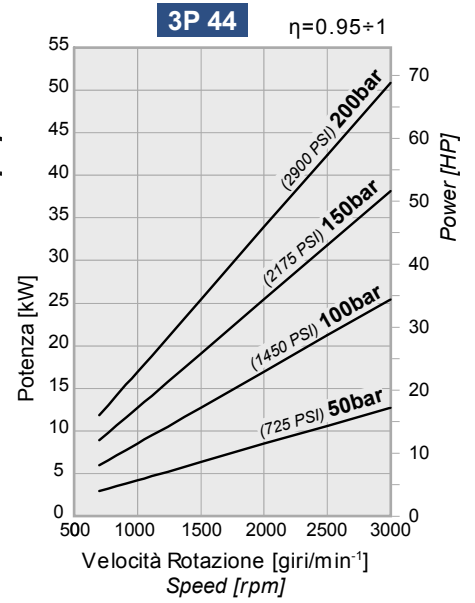
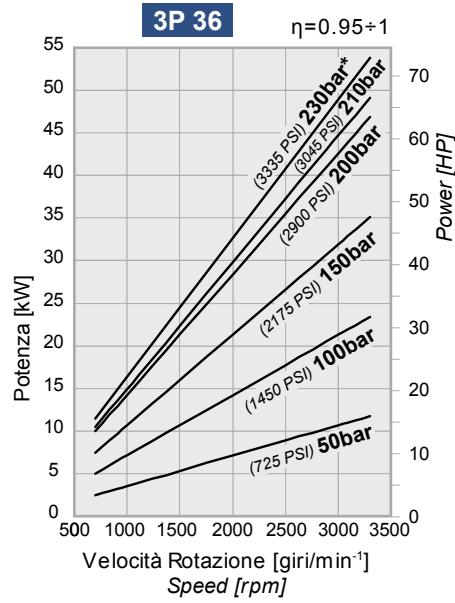
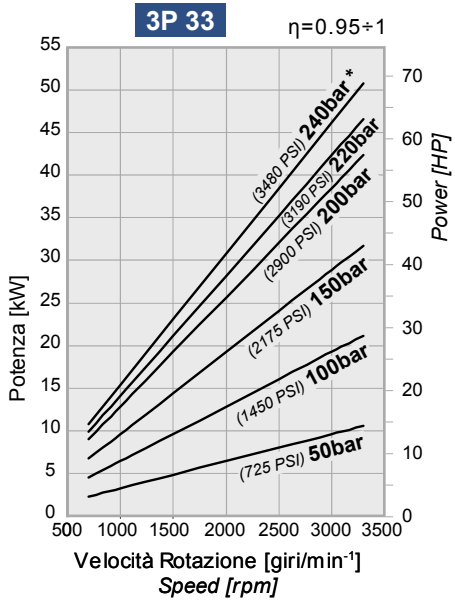

* Solo pompe in ghisa / Only for cast iron pumps

**POMPE GRUPPO
PUMPS GROUP**

1

Standard

Dati tecnici / Technical data

Grandezza Size	Cilindrata Displacement [cm ³ /rev] (in ³ /rev)	Pressione max. d'esercizio Max. working pressure			Velocità max. Max. speed [g/min] (rpm)	Portata max. Max. flow [lt/min] (Gal/min)	Velocità min. Min. speed [g/min] (rpm)	Portata min. Min. flow [lt/min] (Gal/min)	Dimensioni Dimensions		Massa Mass [Kg] (lbs)	Rendimento volumetrico min. Min. volumetric efficiency %
		P1	P2	P3					A	B		
		[bar] (PSI)	[bar] (PSI)	[bar] (PSI)					[mm] (inch)	[mm] (inch)		
1SP A0.9	0.89 (0.05)	240 (3480)	260 (3770)	290 (4205)	6000	5.3 (1.40)	600	0.49 (0.13)	34.80 (1.370)	73.6 (2.898)	0.91 (2.01)	92*
1SP A1.2	1.18 (0.07)	240 (3480)	260 (3770)	290 (4205)	6000	7.1 (1.88)	600	0.65 (0.17)	35.35 (1.392)	74.7 (2.941)	0.93 (2.05)	
1SP A1.6	1.6 (0.10)	240 (3480)	260 (3770)	290 (4205)	6000	9.6 (2.54)	400	0.61 (0.16)	36.20 (1.425)	76.4 (3.008)	0.95 (2.09)	
1SP A2.0	2.0 (0.12)	220 (3190)	250 (3625)	270 (3915)	5500	11 (2.91)	400	0.76 (0.20)	36.95 (1.455)	77.9 (3.067)	0.97 (2.14)	95*
1SP A2.5	2.5 (0.15)	220 (3190)	250 (3625)	270 (3915)	5000	12.5 (3.30)	400	0.95 (0.25)	37.95 (1.494)	79.9 (3.146)	1.00 (2.21)	
1SP A3.2	3.2 (0.20)	210 (3045)	240 (3480)	260 (3770)	4500	14.4 (3.80)	400	1.21 (0.32)	39.30 (1.547)	82.6 (3.252)	1.04 (2.29)	
1SP A3.7	3.7 (0.23)	210 (3045)	240 (3480)	260 (3770)	4000	14.8 (3.91)	400	1.40 (0.37)	40.30 (1.587)	84.6 (3.331)	1.07 (2.36)	
1SP A4.2	4.2 (0.26)	190 (2755)	210 (3045)	230 (3335)	3500	14.7 (3.88)	400	1.60 (0.42)	41.25 (1.624)	86.5 (3.406)	1.10 (2.43)	
1SP A5.0	5.0 (0.31)	180 (2610)	210 (3045)	230 (3335)	3000	15 (3.96)	400	1.90 (0.50)	42.80 (1.685)	89.6 (3.528)	1.14 (2.51)	
1SP A6.3	6.3 (0.38)	170 (2465)	190 (2755)	210 (3045)	2700	17 (4.49)	400	2.39 (0.63)	45.35 (1.785)	94.7 (3.728)	1.22 (2.69)	
1SP A7.8	7.76 (0.47)	170 (2465)	190 (2755)	210 (3045)	2500	19.4 (5.13)	400	2.95 (0.78)	48.20 (1.898)	100.4 (3.953)	1.30 (2.87)	
1SP A9.8	9.78 (0.60)	150 (2175)	170 (2465)	190 (2755)	2000	19.6 (5.18)	400	3.71 (0.98)	52.15 (2.053)	108.3 (4.264)	1.41 (3.11)	

* (Valori rilevati in fase di collaudo a 1500 giri/min / Value collected during the testing at 1500 rpm)

Esempio di ordinazione in codice / Example of ordering code

1SP	A	2.0	D	(H)	-	10	GG	0	(VT)
------------	----------	------------	----------	------------	----------	-----------	-----------	----------	-------------

1SP	Tipo pompa / Pump type	vedi tabella / see table
A	Materiale flangia e coperchio / Flange and cover material	A = Alluminio / Aluminium
2.0	Cilindrata / Displacement	vedi tabella / see table
D	Rotazione destra / Clockwise rotation	D = Rotazione destra / Clockwise rotation S = Rotazione sinistra / Anticlockwise rotation
(H)	Anello di rinforzo per piccola pressione in aspirazione Stiffening seal for low suction pressure	(a richiesta / optional)
—⁽¹⁾	Flangia standard / Standard flange	
10	Tipo albero / Shaft type	10 - 11 - 13 - 14 - 15 - 27
GG	Tipo connessioni / Connections type	GG - NN - TT - UU - NG - TG - UG
0	Posizione connessioni / Connections positions	0 - 1 - 3 - 4
(VT)	Opzioni / Optional	(VT) Guarnizione in Viton (a richiesta) Viton seals (optional) VLP-I (N) Valvola limitatrice di pressione (pag. A-27) Pressure relief valve (page A-27)

⁽¹⁾ Non è necessario indicare la flangia STANDARD / It is not necessary indicate STANDARD flange

Conn Connessioni / Connections

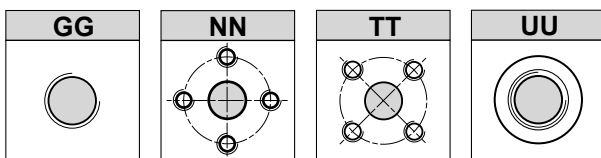

A-26

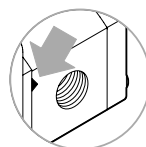

Il segno sul corpo indica il lato aspirazione per le pompe.
The sign on the body identify the suction side for the pumps.

Posizione delle connessioni / Connection positions

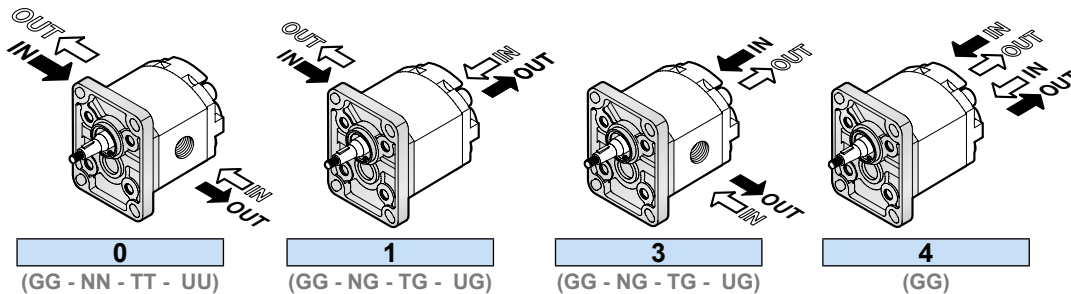

Rotazione / Rotation	
D	S

Standard

**POMPE GRUPPO
PUMPS GROUP**

1

Dimensioni / Dimensions mm (inch)

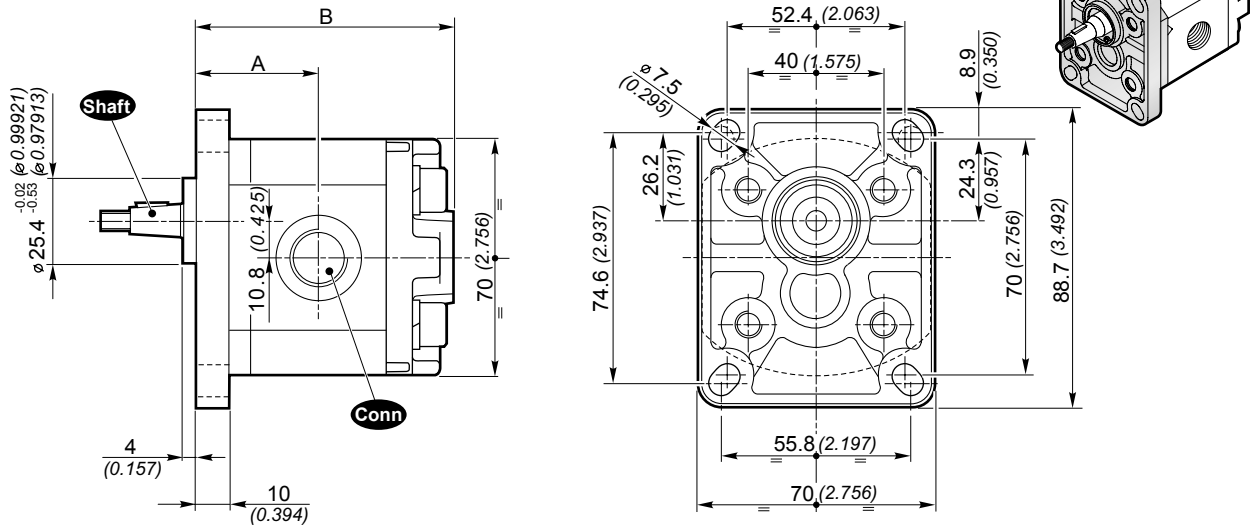

Shaft Alberi disponibili / Available shafts

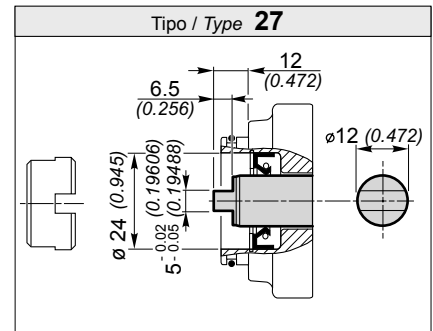
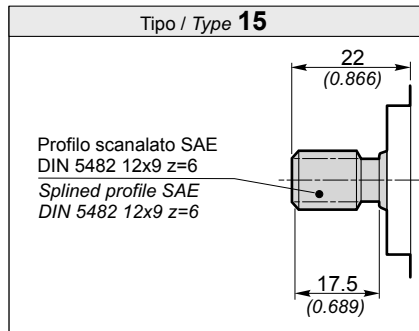
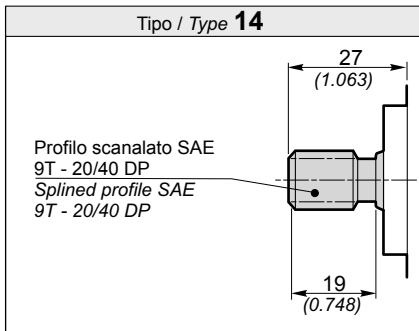
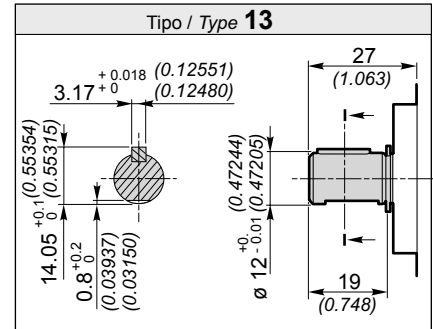
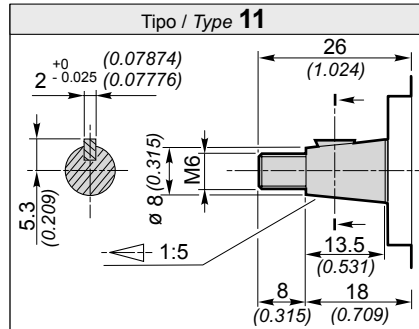
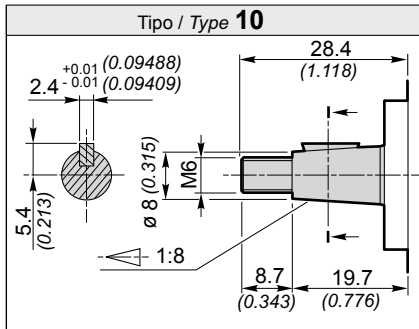

**POMPE GRUPPO
PUMPS GROUP**

1

SAE AA

Dati tecnici / Technical data

Grandezza Size	Cilindrata Displacement [cm ³ /rev] (in ³ /rev)	Pressione max. d'esercizio Max. working pressure			Velocità max. Max. speed [g/min] (rpm)	Portata max. Max. flow [lt/min] (Gal/min)	Velocità min. Min. speed [g/min] (rpm)	Portata min. Min. flow [lt/min] (Gal/min)	Dimensioni Dimensions		Massa Mass [Kg] (lbs)	Rendimento volumetrico min. Min. volumetric efficiency %
		P1 [bar] (PSI)	P2 [bar] (PSI)	P3 [bar] (PSI)					A [mm] (inch)	B [mm] (inch)		
1SP A0.9	0.89 (0.05)	240 (3480)	260 (3770)	290 (4205)	6000	5.3 (1.40)	600	0.49 (0.13)	38.3 (1.508)	77.1 (3.035)	0.91 (2.01)	92*
1SP A1.2	1.18 (0.07)	240 (3480)	260 (3770)	290 (4205)	6000	7.1 (1.88)	600	0.65 (0.17)	38.85 (1.530)	78.2 (3.079)	0.93 (2.05)	
1SP A1.6	1.6 (0.10)	240 (3480)	260 (3770)	290 (4205)	6000	9.6 (2.54)	400	0.61 (0.16)	39.7 (1.563)	79.9 (3.146)	0.95 (2.09)	
1SP A2.0	2.0 (0.12)	220 (3190)	250 (3625)	270 (3915)	5500	11 (2.91)	400	0.76 (0.20)	40.45 (1.593)	81.4 (3.205)	0.97 (2.14)	95*
1SP A2.5	2.5 (0.15)	220 (3190)	250 (3625)	270 (3915)	5000	12.5 (3.30)	400	0.95 (0.25)	41.45 (1.632)	83.4 (3.283)	1.00 (2.21)	
1SP A3.2	3.2 (0.20)	210 (3045)	240 (3480)	260 (3770)	4500	14.4 (3.80)	400	1.21 (0.32)	42.8 (1.685)	86.1 (3.390)	1.04 (2.29)	
1SP A3.7	3.7 (0.23)	210 (3045)	240 (3480)	260 (3770)	4000	14.8 (3.91)	400	1.40 (0.37)	43.8 (1.724)	88.1 (3.469)	1.07 (2.369)	
1SP A4.2	4.2 (0.26)	190 (2755)	210 (3045)	230 (3335)	3500	14.7 (3.88)	400	1.60 (0.42)	44.75 (1.762)	90 (3.543)	1.10 (2.43)	
1SP A5.0	5.0 (0.31)	180 (2610)	210 (3045)	230 (3335)	3000	15 (3.96)	400	1.90 (0.50)	46.3 (1.823)	93.1 (3.665)	1.14 (2.51)	
1SP A6.3	6.3 (0.38)	170 (2465)	190 (2755)	210 (3045)	2700	17 (4.49)	400	2.39 (0.63)	48.85 (1.923)	98.2 (3.866)	1.22 (2.69)	
1SP A7.8	7.76 (0.47)	170 (2465)	190 (2755)	210 (3045)	2500	19.4 (5.13)	400	2.95 (0.78)	51.7 (2.035)	103.9 (4.091)	1.30 (2.87)	
1SP A9.8	9.78 (0.60)	150 (2175)	170 (2465)	190 (2755)	2000	19.6 (5.18)	400	3.71 (0.98)	55.65 (2.191)	111.8 (4.402)	1.41 (3.11)	

* (Valori rilevati in fase di collaudo a 1500 giri/min / Value collected during the testing at 1500 rpm)

Esempio di ordinazione in codice / Example of ordering code

1SP	A	2.0	D	SAE AA	(H)	10	GG	0	(VT)
------------	----------	------------	----------	---------------	------------	-----------	-----------	----------	-------------

1SP	Typo pompa / Pump type	vedi tabella / see table
A	Materiale flangia e coperchio / Flange and cover material	A = Alluminio / Aluminium
2.0	Cilindrata / Displacement	vedi tabella / see table
D	Rotazione destra / Clockwise rotation	D = Rotazione destra / Clockwise rotation S = Rotazione sinistra / Anticlockwise rotation
SAE AA	Typo flangia / Flange type	SAE AA
(H)	Anello di rinforzo per piccola pressione in aspirazione Stiffening seal for low suction pressure	(a richiesta / (optional))
—		
10	Typo albero / Shaft type	10 - 11 - 13 - 14 - 15 - 27
GG	Typo connessioni / Connections type	GG - NN - TT - UU - NG - TG - UG
0	Posizione connessioni / Connections positions	0 - 1 - 3 - 4
(VT)	Opzioni / Optional	(VT) Guarnizione in Viton (a richiesta) Viton seals (optional) VLP-I (N) Valvola limitatrice di pressione (pag. A-27) Pressure relief valve (page A-27)

Conn Connessioni / Connections

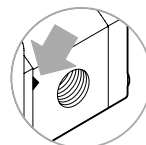
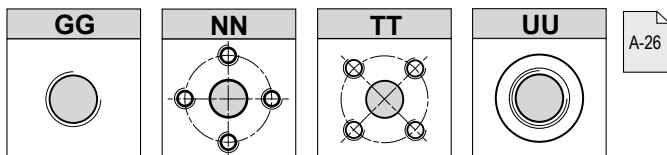

Il segno sul corpo indica il lato aspirazione per le pompe.
The sign on the body identify the suction side for the pumps.

Posizione delle connessioni / Connection positions

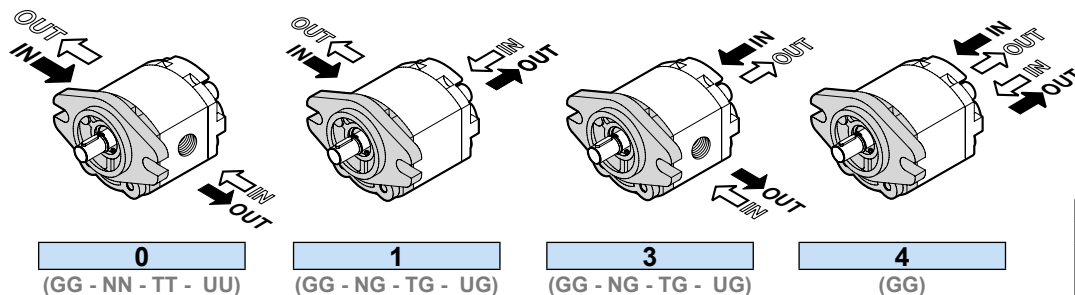

Rotazione / Rotation	
D	S

SAE AA **POMPE GRUPPO**
PUMPS GROUP **1**

Dimensioni / Dimensions

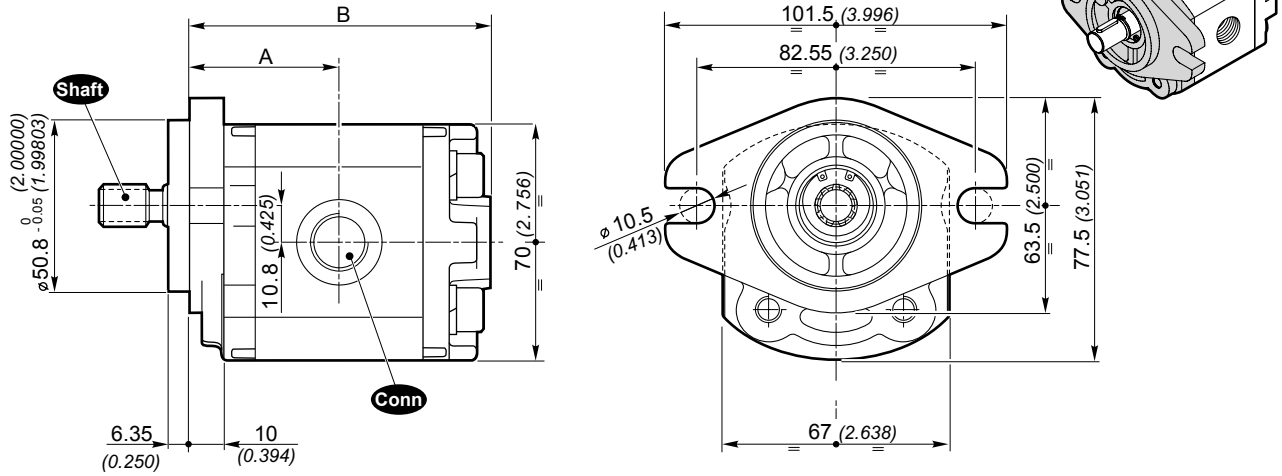

Shaft Alberi disponibili / Available shafts

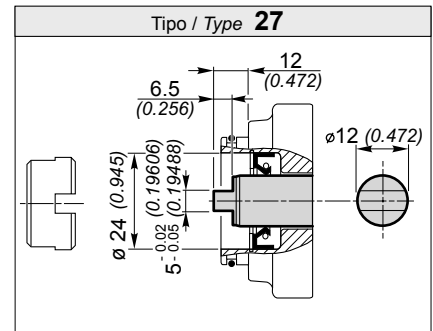
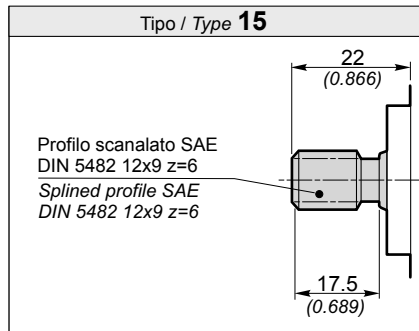
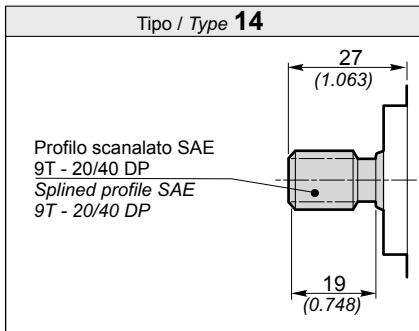
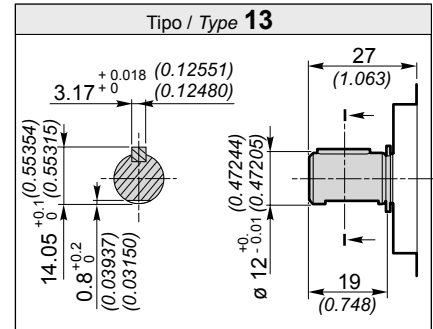
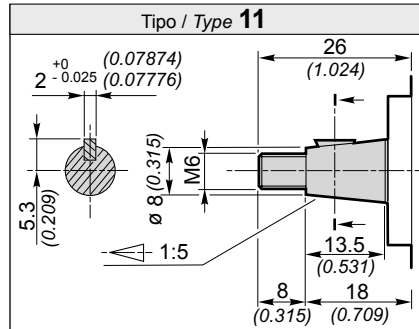
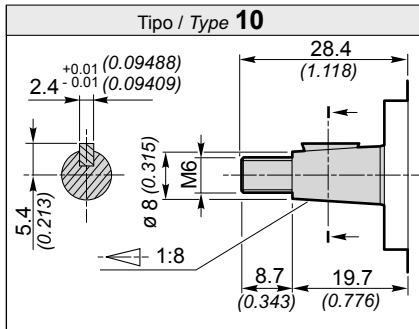

**POMPE GRUPPO
PUMPS GROUP**

1

MC 32

**Minicentralina
Power-pack**

Dati tecnici / Technical data

Grandezza Size	Cilindrata Displacement [cm ³ /rev] (in ³ /rev)	Pressione max. d'esercizio Max. working pressure			Velocità max. Max. speed [g/min] (rpm)	Portata max. Max. flow [l/min] (Gal/min)	Velocità min. Min. speed [g/min] (rpm)	Portata min. Min. flow [l/min] (Gal/min)	Dimensioni Dimensions			Massa Mass [Kg] (lbs)	Rendimento volumetrico min. Min. volumetric efficiency %
		P1 [bar] (PSI)	P2 [bar] (PSI)	P3 [bar] (PSI)					A [mm] (inch)	B [mm] (inch)	L ① [mm] (inch)		
1SP A0.9	0.89 (0.05)	210 (3045)	240 (3480)	260 (3770)	6000	5.3 (1.40)	600	0.49 (0.13)	73.1 (2.878)	61.6 (2.425)	80 (3.150)	0.91 (2.01)	92*
1SP A1.2	1.18 (0.07)	210 (3045)	240 (3480)	260 (3770)	6000	7.1 (1.88)	600	0.65 (0.17)	74.2 (2.921)	62.7 (2.469)	80 (3.150)	0.93 (2.05)	
1SP A1.6	1.6 (0.10)	210 (3045)	240 (3480)	260 (3770)	6000	9.6 (2.54)	400	0.61 (0.16)	75.9 (2.988)	64.4 (2.535)	80 (3.150)	0.95 (2.09)	
1SP A2.0	2.0 (0.12)	210 (3045)	240 (3480)	260 (3770)	5500	11 (2.91)	400	0.76 (0.20)	77.4 (3.047)	65.9 (2.594)	80 (3.150)	0.97 (2.14)	95*
1SP A2.5	2.5 (0.15)	210 (3045)	240 (3480)	260 (3770)	5000	12.5 (3.30)	400	0.95 (0.25)	79.4 (3.126)	67.9 (2.673)	85 (3.346)	1.00 (2.21)	
1SP A3.2	3.2 (0.20)	200 (2900)	230 (3335)	250 (3625)	4500	14.4 (3.80)	400	1.21 (0.32)	82.1 (3.232)	70.6 (2.780)	85 (3.346)	1.04 (2.29)	
1SP A3.7	3.7 (0.23)	200 (2900)	230 (3335)	250 (3625)	4000	14.8 (3.91)	400	1.40 (0.37)	84.1 (3.311)	72.6 (2.858)	90 (3.543)	1.07 (2.36)	
1SP A4.2	4.2 (0.26)	180 (2610)	210 (3045)	230 (3335)	3500	14.7 (3.88)	400	1.60 (0.42)	86 (3.386)	74.5 (2.933)	90 (3.543)	1.10 (2.43)	
1SP A5.0	5.0 (0.31)	180 (2610)	210 (3045)	230 (3335)	3000	15 (3.96)	400	1.90 (0.50)	89.1 (3.508)	77.6 (3.055)	95 (3.740)	1.14 (2.51)	
1SP A6.3	6.3 (0.38)	170 (2465)	190 (2755)	210 (3045)	2700	17 (4.49)	400	2.39 (0.63)	94.2 (3.709)	82.7 (3.256)	100 (3.937)	1.22 (2.69)	
1SP A7.8	7.76 (0.47)	170 (2465)	190 (2755)	210 (3045)	2500	19.4 (5.13)	400	2.95 (0.78)	99.9 (3.933)	88.4 (3.480)	105 (4.134)	1.30 (2.87)	
1SP A9.8	9.78 (0.60)	150 (2175)	170 (2465)	190 (2755)	2000	19.6 (5.18)	400	3.71 (0.98)	107.8 (4.244)	96.3 (3.791)	115 (4.528)	1.41 (3.11)	

* (Valori rilevati in fase di collaudo a 1500 giri/min / Value collected during the testing at 1500 rpm)

Esempio di ordinazione in codice / Example of ordering code

1SP	A	3.7	D	MC 32	-	27	G05	(VT)
------------	----------	------------	----------	--------------	----------	-----------	------------	-------------

1SP	Tipo pompa / Pump type	vedi tabella / see table
A	Materiale flangia e coperchio / Flange and cover material	A = Alluminio / Aluminium
3.7	Cilindrata / Displacement	vedi tabella / see table
D	Rotazione destra / Clockwise rotation	D = Rotazione destra / Clockwise rotation S = Rotazione sinistra / Anticlockwise rotation
MC 32	Tipo flangia / Flange type	MC 32
—		
27	Tipo albero / Shaft type	27 - 10 - 11 - 15
G05	Tipo e posizione connessioni / Connections type and position	G05
(VT)	Opzioni / Optional	(VT) Guarnizione in Viton (a richiesta) Viton seals (optional)

Conn Tipo e posizione connessioni / Connections type and position

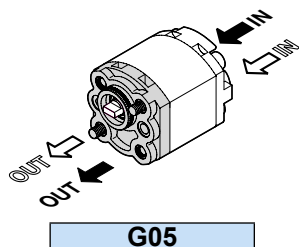

Rotazione / Rotation	
D	S

**Minicentralina
Power-pack**

MC 32

**POMPE GRUPPO
PUMPS GROUP**

1

Dimensioni / Dimensions

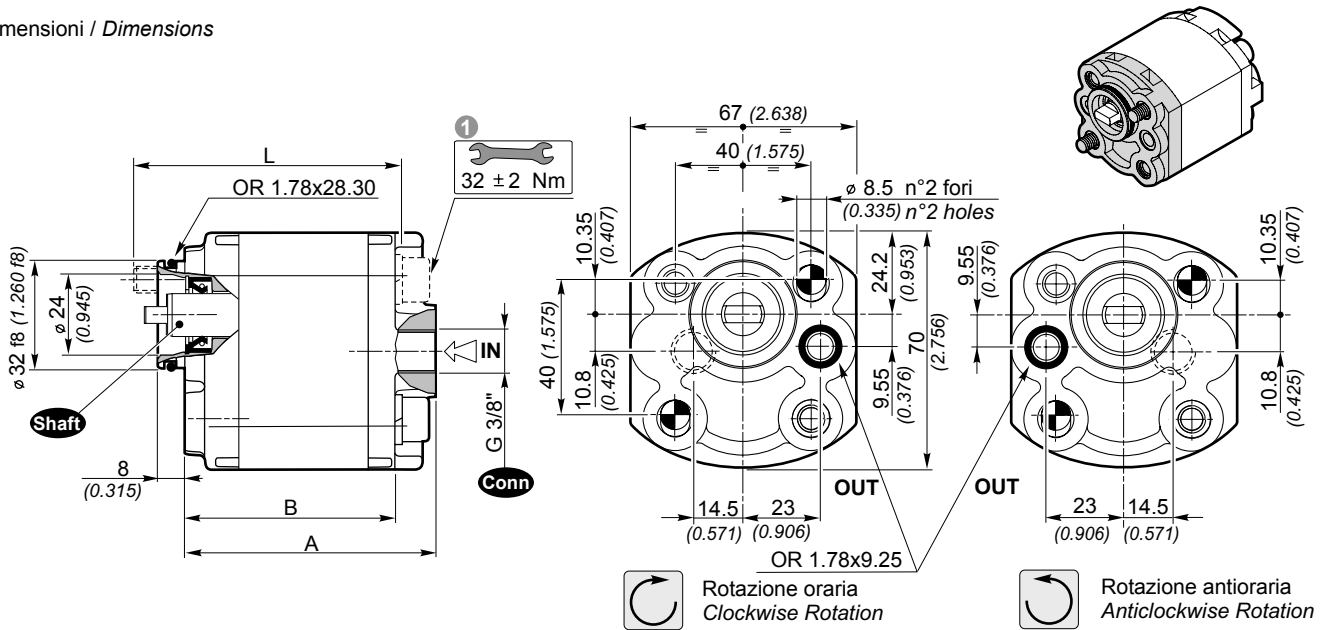

Shaft Alberi disponibili / Available shafts

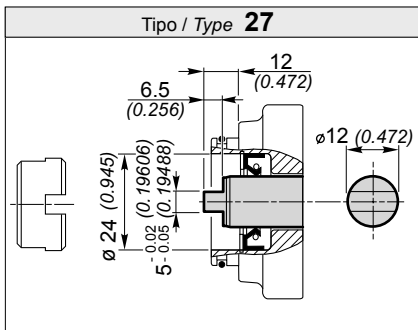
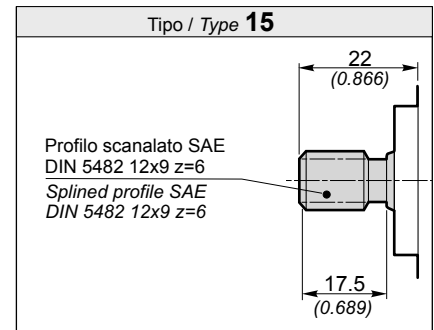
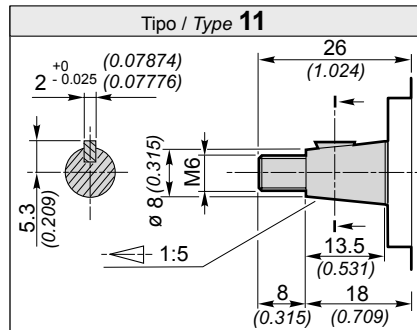
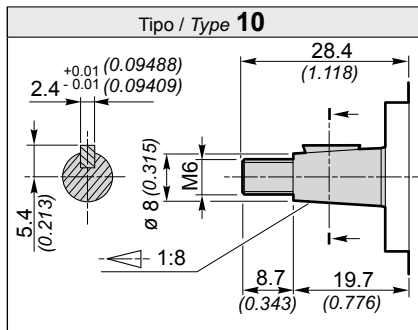

1 Coppia di serraggio viti: $32 \pm 2\text{ Nm}$. Utilizzare viti classe 10.9 - 12.9 UNI EN 20898/1.
Il Kit di viti per il fissaggio della pompa è da ordinare separatamente.
Codice di ordinazione del Kit di fissaggio:

0019W + Lunghezza **L** (vedi tabella)
+ Length **L** (see table)

Il fissaggio della pompa può essere effettuato con 2 viti prigioniere in materiale classe 10.9 - 12.9 preserrate a $25 \pm 2\text{ Nm}$.
Fissare la pompa mediante dadi autobloccanti con coppia di serraggio $32 \pm 2\text{ Nm}$.

Il senso di rotazione della pompa deve essere richiesto in fase di ordinazione perchè questo tipo di intervento deve necessariamente essere eseguito in fabbrica.

1 Tightening torque of screws: $283 \pm 18\text{ lb-in}$. Use screws type 10.9 - 12.9 UNI EN 20898/1.
The screws kit for the pump assembling should be ordered separately.
Ordering code of assembling Kit:

The assembling of the pump should be effected by 2 screw studs type 10.9 - 12.9 pre-tighten at $221 \pm 18\text{ lb-in}$.
Fix the pump by self-locking nuts with tightening torque $283 \pm 18\text{ lb-in}$.

The rotation direction shall be specified while issuing the order because this kind of operation must necessarily be carried out at our premises.

**POMPE GRUPPO
PUMPS GROUP**

1

E 32 BX

(Fissaggio da minicentralina)
(Power-pack fixing)

Dati tecnici / Technical data

Grandezza Size	Cilindrata Displacement [cm ³ /rev] (in ³ /rev)	Pressione max. d'esercizio Max. working pressure			Velocità max. Max. speed [g/min] (rpm)	Portata max. Max. flow [l/min] (Gal/min)	Velocità min. Min. speed [[g/min] (rpm)	Portata min. Min. flow [l/min] (Gal/min)	Dimensioni Dimensions				Massa Mass [Kg] (lbs)	Rendimento volumetrico min. Min. volumetric efficiency %
		P1 [bar] (PSI)	P2 [bar] (PSI)	P3 [bar] (PSI)					A [mm] (inch)	B [mm] (inch)	C [mm] (inch)	L ① [mm] (inch)		
1SP A0.9	0.89 (0.05)	210 (3045)	240 (3480)	260 (3770)	6000	5.3 (1.40)	600	0.49 (0.13)	73.6 (2.898)	34.8 (1.370)	61.6 (2.425)	80 (3.150)	0.91 (2.01)	92*
1SP A1.2	1.18 (0.07)	210 (3045)	240 (3480)	260 (3770)	6000	7.1 (1.88)	600	0.65 (0.17)	74.7 (2.941)	35.35 (1.392)	62.7 (2.469)	80 (3.150)	0.93 (2.05)	
1SP A1.6	1.6 (0.10)	210 (3045)	240 (3480)	260 (3770)	6000	9.6 (2.54)	400	0.61 (0.16)	76.4 (3.008)	36.2 (1.425)	64.4 (2.535)	80 (3.150)	0.95 (2.09)	
1SP A2.0	2.0 (0.12)	210 (3045)	240 (3480)	260 (3770)	5500	11 (2.91)	400	0.76 (0.20)	77.9 (3.067)	36.95 (1.455)	65.9 (2.594)	80 (3.150)	0.97 (2.14)	95*
1SP A2.5	2.5 (0.15)	210 (3045)	240 (3480)	260 (3770)	5000	12.5 (3.30)	400	0.95 (0.25)	79.9 (3.146)	37.95 (1.494)	67.9 (2.673)	85 (3.346)	1.00 (2.21)	
1SP A3.2	3.2 (0.20)	200 (2900)	230 (3335)	250 (3625)	4500	14.4 (3.80)	400	1.21 (0.32)	82.6 (3.252)	39.3 (1.547)	70.6 (2.780)	85 (3.346)	1.04 (2.29)	
1SP A3.7	3.7 (0.23)	200 (2900)	230 (3335)	250 (3625)	4000	14.8 (3.91)	400	1.40 (0.37)	84.6 (3.331)	40.3 (1.587)	72.6 (2.858)	90 (3.543)	1.07 (2.36)	
1SP A4.2	4.2 (0.26)	180 (2610)	210 (3045)	230 (3335)	3500	14.7 (3.88)	400	1.60 (0.42)	86.5 (3.406)	41.25 (1.624)	74.5 (2.933)	90 (3.543)	1.10 (2.43)	
1SP A5.0	5.0 (0.31)	180 (2610)	210 (3045)	230 (3335)	3000	15 (3.96)	400	1.90 (0.50)	89.6 (3.528)	42.8 (1.685)	77.6 (3.055)	95 (3.740)	1.14 (2.51)	
1SP A6.3	6.3 (0.38)	170 (2465)	190 (2755)	210 (3045)	2700	17 (4.49)	400	2.39 (0.63)	94.7 (3.728)	45.35 (1.785)	82.7 (3.256)	100 (3.937)	1.22 (2.69)	
1SP A7.8	7.76 (0.47)	170 (2465)	190 (2755)	210 (3045)	2500	19.4 (5.13)	400	2.95 (0.78)	100.4 (3.953)	48.2 (1.898)	88.4 (3.480)	105 (4.134)	1.30 (2.87)	
1SP A9.8	9.78 (0.60)	150 (2175)	170 (2465)	190 (2755)	2000	19.6 (5.18)	400	3.71 (0.98)	108.3 (4.264)	52.15 (2.053)	96.3 (3.791)	115 (4.528)	1.41 (3.11)	

* (Valori rilevati in fase di collaudo a 1500 giri/min / Value collected during the testing at 1500 rpm)

Esempio di ordinazione in codice / Example of ordering code

1SP	A	3.7	D	E32 BX	-	17	GG0	(VT)
------------	----------	------------	----------	---------------	----------	-----------	------------	-------------

1SP	Tipo pompa / Pump type	vedi tabella / see table
A	Materiale flangia e coperchio / Flange and cover material	A = Alluminio / Aluminium
3.7	Cilindrata / Displacement	vedi tabella / see table
D	Rotazione destra / Clockwise rotation	D = Rotazione destra / Clockwise rotation S = Rotazione sinistra / Anticlockwise rotation
E 32 BX	Tipo flangia / Flange type	E 32 BX
-		
17	Tipo albero / Shaft type	17 - M32
GG	Tipo connessioni / Connections type	GG - NN - TT - UU - NG - TG - UG
0	Tipo connessioni / Connections type	0 - 1 - 3 - 4
(VT)	Opzioni / Optional	(VT) Guarnizione in Viton (a richiesta) Viton seals (optional) VLP-I (N) Valvola limitatrice di pressione (pag. A-27) Pressure relief valve (page A-27)

Conn Connessioni / Connections

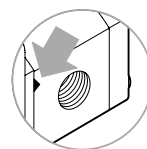
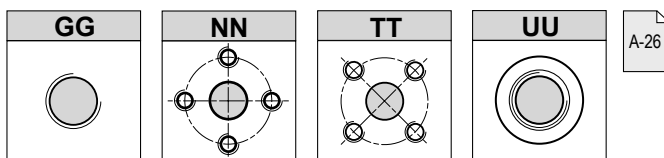

Il segno sul corpo indica il lato aspirazione per le pompe.
The sign on the body identify the suction side for the pumps.

Posizione delle connessioni / Connection positions

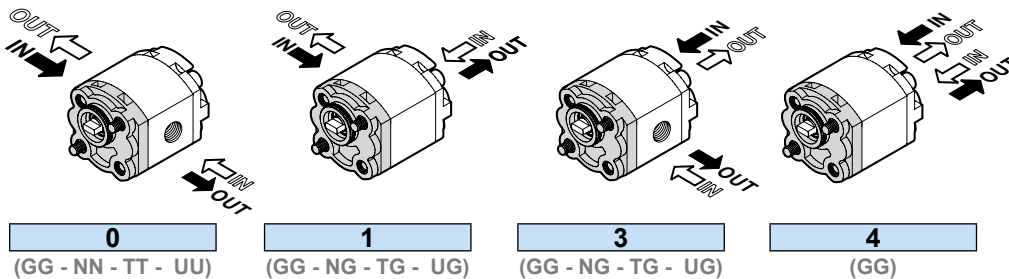

Rotazione / Rotation	
D	S

(Fissaggio da minicentralina)
(Power-pack fixing)

E 32 BX

POMPE GRUPPO
PUMPS GROUP

1

Dimensioni / Dimensions

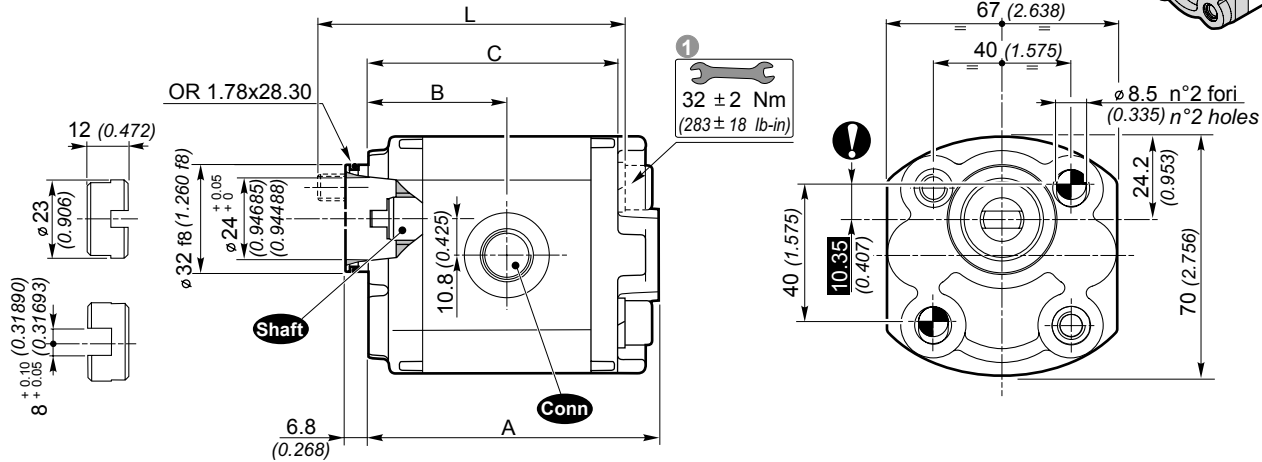
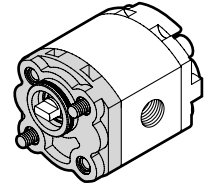

Shaft Alberi disponibili / Available shafts

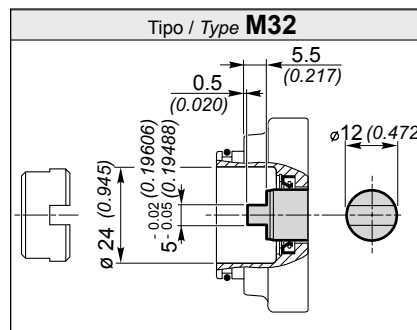
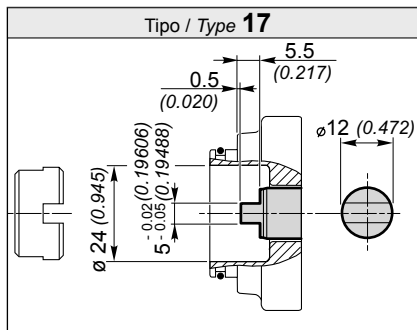

1 Coppia di serraggio viti: 32 ± 2Nm. Utilizzare viti classe 10.9 - 12.9 UNI EN 20898/1.
Il Kit di viti per il fissaggio della pompa è da ordinare separatamente.
Codice di ordinazione del Kit di fissaggio:

1 Tightening torque of screws: 283 ± 18 lb-in. Use screws type 10.9 - 12.9 UNI EN 20898/1.
The screws kit for the pump assembling should be ordered separately.
Ordering code of assembling Kit:

0019W + Lunghezza L (vedi tabella)
+ Lenght L (see table)

Il fissaggio della pompa può essere effettuato con 2 viti prigioniere in materiale classe 10.9 - 12.9 preserrate a 25 ± 2Nm.
Fissare la pompa mediante dadi autobloccanti con coppia di serraggio 32 ± 2Nm.

The assembling of the pump should be effected with 2 screw studs type 10.9 - 12.9 pre-tighten at 221 ± 18 lb-in.
Fix the pump by self-locking nuts with tightening torque 283 ± 18 lb-in.

**POMPE GRUPPO
PUMPS GROUP**

1

E 32 CX

Dati tecnici / Technical data

Grandezza Size	Cilindrata Displacement [cm ³ /rev] (in ³ /rev)	Pressione max. d'esercizio Max. working pressure			Velocità max. Max. speed [g/min] (rpm)	Portata max. Max. flow [l/min] (Gal/min)	Velocità min. Min. speed [g/min] (rpm)	Portata min. Min. flow [l/min] (Gal/min)	Dimensioni Dimensions				Massa Mass [Kg] (lbs)	Rendimento volumetrico min. Min. volumetric efficiency %
		P1 [bar] (PSI)	P2 [bar] (PSI)	P3 [bar] (PSI)					A [mm] (inch)	B [mm] (inch)	C [mm] (inch)	L ① [mm] (inch)		
1SP A0.9	0.89 (0.05)	210 (3045)	240 (3480)	260 (3770)	6000	5.3 (1.40)	600	0.49 (0.13)	73.6 (2.898)	34.8 (1.370)	61.6 (2.425)	80 (3.150)	0.91 (2.01)	92*
1SP A1.2	1.18 (0.07)	210 (3045)	240 (3480)	260 (3770)	6000	7.1 (1.88)	600	0.65 (0.17)	74.7 (2.941)	35.35 (1.392)	62.7 (2.469)	80 (3.150)	0.93 (2.05)	
1SP A1.6	1.6 (0.10)	210 (3045)	240 (3480)	260 (3770)	6000	9.6 (2.54)	400	0.61 (0.16)	76.4 (3.008)	36.2 (1.425)	64.4 (2.535)	80 (3.150)	0.95 (2.09)	
1SP A2.0	2.0 (0.12)	210 (3045)	240 (3480)	260 (3770)	5500	11 (2.91)	400	0.76 (0.20)	77.9 (3.067)	36.95 (1.455)	65.9 (2.594)	80 (3.150)	0.97 (2.14)	95*
1SP A2.5	2.5 (0.15)	210 (3045)	240 (3480)	260 (3770)	5000	12.5 (3.30)	400	0.95 (0.25)	79.9 (3.146)	37.95 (1.494)	67.9 (2.673)	85 (3.346)	1.00 (2.21)	
1SP A3.2	3.2 (0.20)	200 (2900)	230 (3335)	250 (3625)	4500	14.4 (3.80)	400	1.21 (0.32)	82.6 (3.252)	39.3 (1.547)	70.6 (2.780)	85 (3.346)	1.04 (2.29)	
1SP A3.7	3.7 (0.23)	200 (2900)	230 (3335)	250 (3625)	4000	14.8 (3.91)	400	1.40 (0.37)	84.6 (3.331)	40.3 (1.587)	72.6 (2.858)	90 (3.543)	1.07 (2.36)	
1SP A4.2	4.2 (0.26)	180 (2610)	210 (3045)	230 (3335)	3500	14.7 (3.88)	400	1.60 (0.42)	86.5 (3.406)	41.25 (1.624)	74.5 (2.933)	90 (3.543)	1.10 (2.43)	
1SP A5.0	5.0 (0.31)	180 (2610)	210 (3045)	230 (3335)	3000	15 (3.96)	400	1.90 (0.50)	89.6 (3.528)	42.8 (1.685)	77.6 (3.055)	95 (3.740)	1.14 (2.51)	
1SP A6.3	6.3 (0.38)	170 (2465)	190 (2755)	210 (3045)	2700	17 (4.49)	400	2.39 (0.63)	94.7 (3.728)	45.35 (1.785)	82.7 (3.256)	100 (3.937)	1.22 (2.69)	
1SP A7.8	7.76 (0.47)	170 (2465)	190 (2755)	210 (3045)	2500	19.4 (5.13)	400	2.95 (0.78)	100.4 (3.953)	48.2 (1.898)	88.4 (3.480)	105 (4.134)	1.30 (2.87)	
1SP A9.8	9.78 (0.60)	150 (2175)	170 (2465)	190 (2755)	2000	19.6 (5.18)	400	3.71 (0.98)	108.3 (4.264)	52.15 (2.053)	96.3 (3.791)	115 (4.528)	1.41 (3.11)	

* (Valori rilevati in fase di collaudo a 1500 giri/min / Value collected during the testing at 1500 rpm)

Esempio di ordinazione in codice / Example of ordering code

1SP	A	3.7	D	E32 CX	-	17	GG	0	(VT)
------------	----------	------------	----------	---------------	----------	-----------	-----------	----------	-------------

1SP	Tipo pompa / Pump type	vedi tabella / see table
A	Materiale flangia e coperchio / Flange and cover material	A = Alluminio / Aluminium
3.7	Cilindrata / Displacement	vedi tabella / see table
D	Rotazione destra / Clockwise rotation	D = Rotazione destra / Clockwise rotation S = Rotazione sinistra / Anticlockwise rotation
E 32 CX	Tipo flangia / Flange type	E 32 CX
—		
17	Tipo albero / Shaft type	17 - M32
GG	Tipo connessioni / Connections type	GG - NN - TT - UU - NG - TG - UG
0	Tipo connessioni / Connections type	0 - 1 - 3 - 4
(VT)	Opzioni / Optional	(VT) Guarnizione in Viton (a richiesta) Viton seals (optional) VLP-I (N) Valvola limitatrice di pressione (pag. A-27) Pressure relief valve (page A-27)

Conn Connessioni / Connections

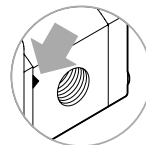
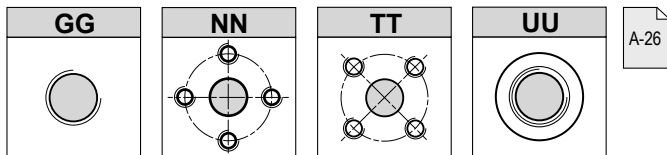

Il segno sul corpo indica il lato aspirazione per le pompe.
The sign on the body identify the suction side for the pumps.

Posizione delle connessioni / Connection positions

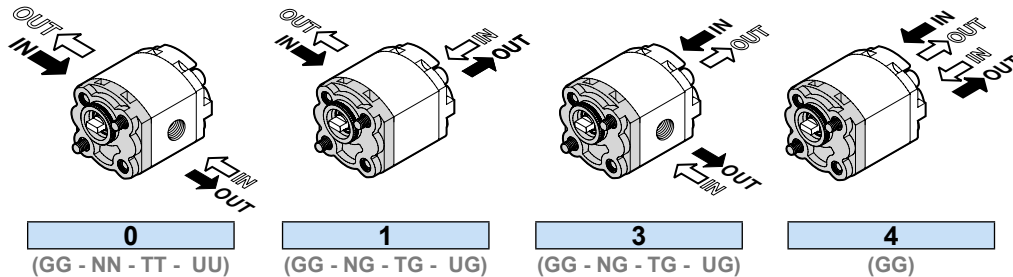

Rotazione / Rotation	
D	S

E 32 CX **POMPE GRUPPO**
PUMPS GROUP **1**

Dimensioni / Dimensions

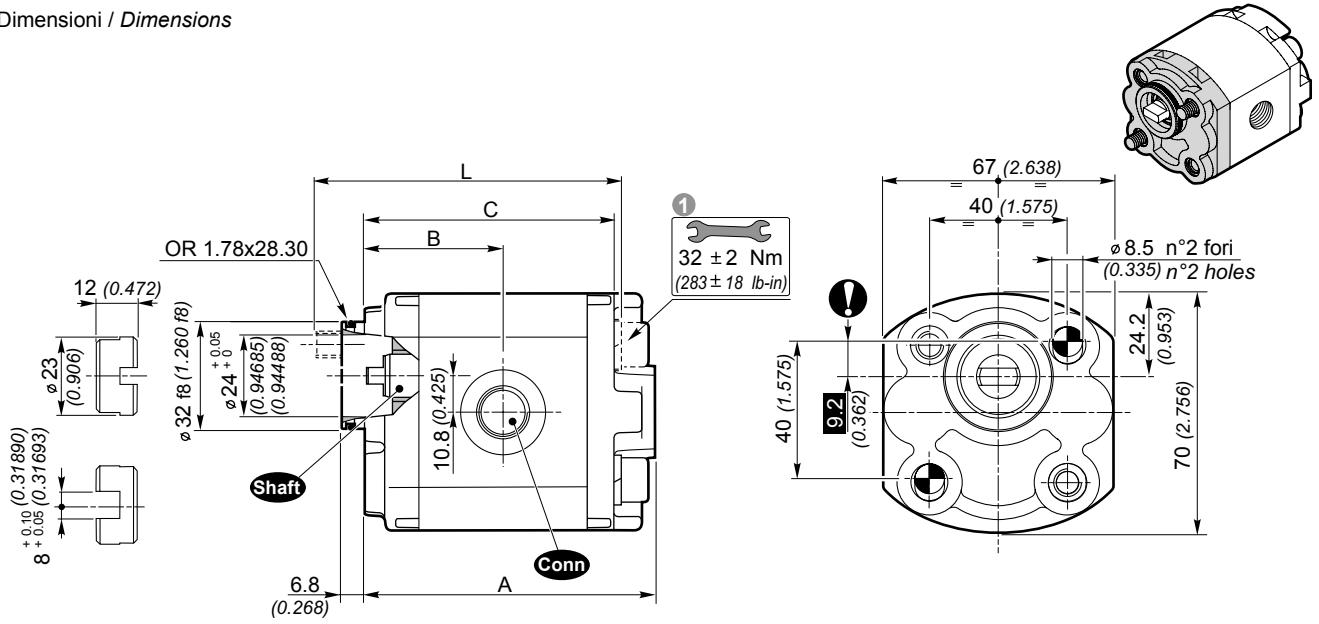

Shaft Alberi disponibili / Available shafts

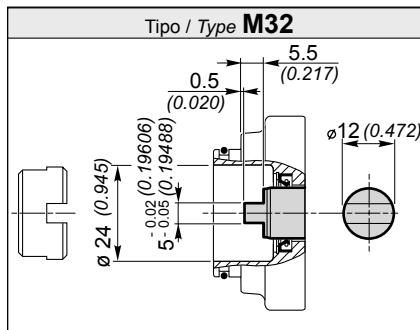
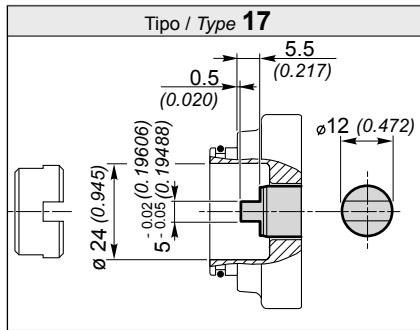

① Coppia di serraggio viti: 32 ± 2Nm. Utilizzare viti classe 10.9 - 12.9 UNI EN 20898/1.
Il Kit di viti per il fissaggio della pompa è da ordinare separatamente.
Codice di ordinazione del Kit di fissaggio:

① Tightening torque of screws: 283 ± 18 lb-in. Use screws type 10.9 - 12.9 UNI EN 20898/1.
The screws kit for the pump assembling should be ordered separately.
Ordering code of assembling Kit:

0019W + Lunghezza L (vedi tabella)
+ Length L (see table)

Il fissaggio della pompa può essere effettuato con 2 viti prigioniere in materiale classe 10.9 - 12.9 preserrate a 25 ± 2Nm.
Fissare la pompa mediante dadi autobloccanti con coppia di serraggio 32 ± 2Nm.

The assembling of the pump should be effected with 2 screw studs type 10.9 - 12.9 pre-tighten at 221 ± 18 lb-in.
Fix the pump by self-locking nuts with tightening torque 283 ± 18 lb-in.

POMPE GRUPPO
PUMPS GROUP

1

CONNESSIONI / CONNECTIONS

NN

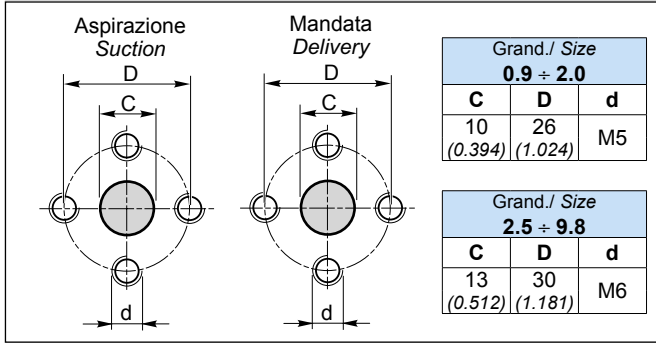

GG

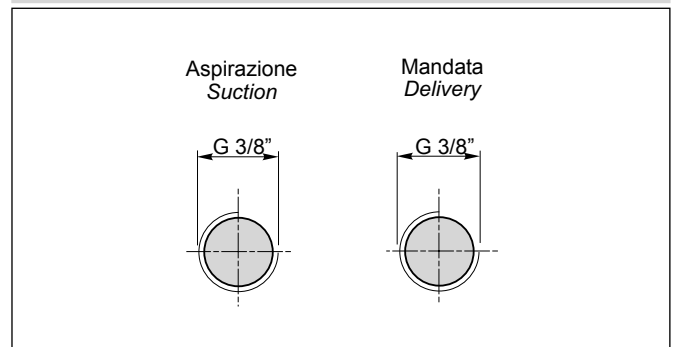

TT

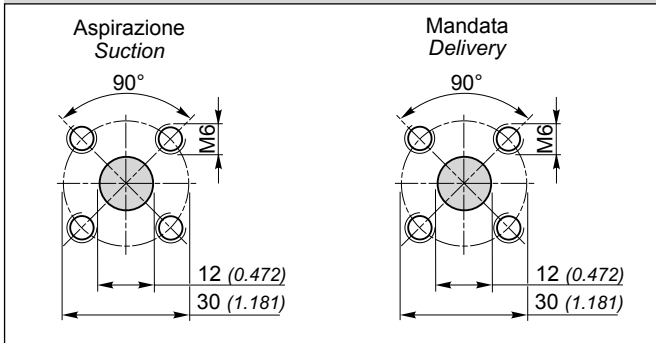

UU

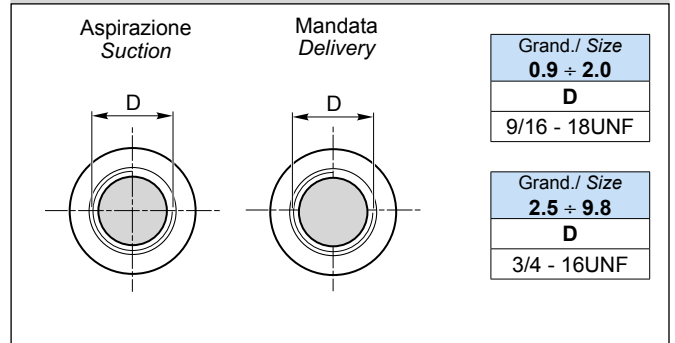

GG4

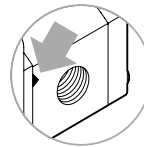
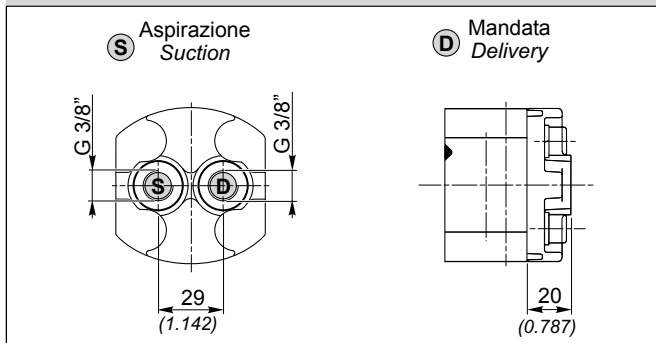

Il segno sul corpo indica il **lato aspirazione** per le pompe.
The sign on the body identify the **suction side** for the pumps.

Posizione delle connessioni / Connections positions

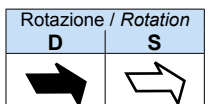
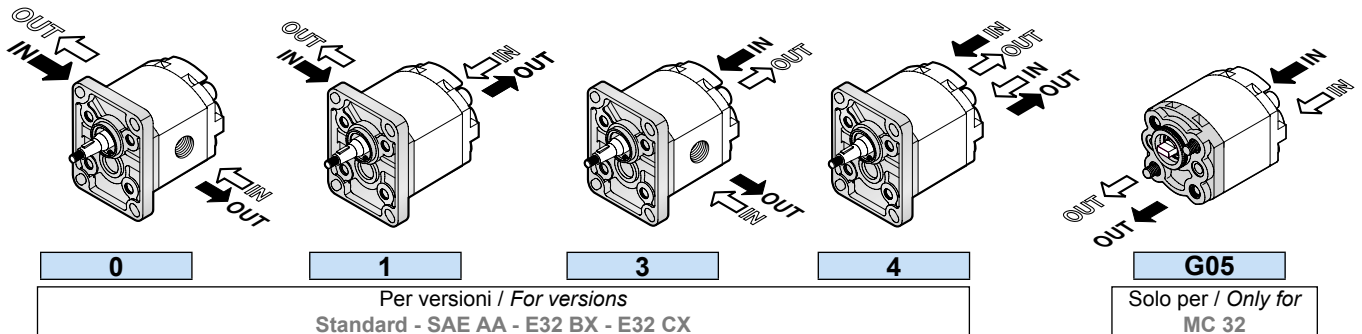

OPZIONI / OPTIONAL

POMPE GRUPPO
PUMPS GROUP

1

VLP- I (N)

Valvola limitatrice di pressione
Pressure relief valve

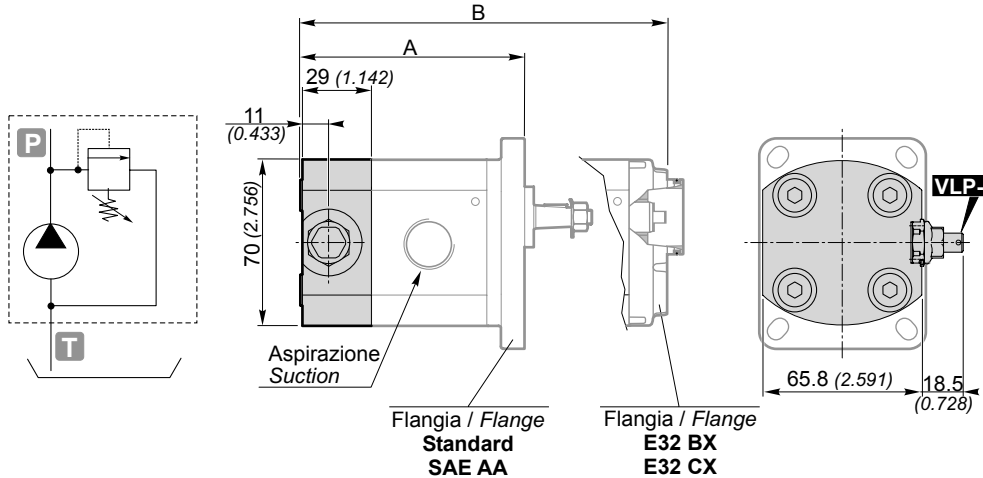
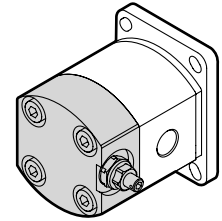

	A		B
	Standard	SAE AA	E32 BX E32 CX
1SP A0.9	82.6 (3.252)	86.1 (3.390)	82.6 (3.252)
1SP A1.2	84.2 (3.315)	87.7 (3.453)	84.2 (3.315)
1SP A1.6	85.4 (3.362)	88.9 (3.500)	85.4 (3.362)
1SP A2.0	86.9 (3.421)	90.4 (3.559)	86.9 (3.421)
1SP A2.5	89.4 (3.520)	92.9 (3.657)	89.4 (3.520)
1SP A3.2	91.6 (3.606)	95.1 (3.744)	91.6 (3.606)
1SP A3.7	94.1 (3.705)	97.6 (3.843)	94.1 (3.705)
1SP A4.2	95.5 (3.760)	99.0 (3.898)	95.5 (3.760)
1SP A5.0	99.1 (3.902)	102.6 (4.039)	99.1 (3.902)
1SP A6.3	104.2 (4.102)	107.7 (4.240)	104.2 (4.102)
1SP A7.8	109.9 (4.327)	113.4 (4.465)	109.9 (4.327)
1SP A9.8	117.3 (4.618)	120.8 (4.756)	117.3 (4.618)

NB.
La valvola limitatrice di pressione si applica sostituendo il coperchio posteriore (previsto solo scarico interno).

Warning.
The pressure relief valve can be applied by substituting the rear cover (only internal relief is set).

L'apertura della valvola limitatrice di pressione deve avvenire per tempi non superiori ai 10 secondi ogni minuto per evitare il surriscaldamento della pompa.

The opening of the pressure relief valve should be carry out for times not over 10" each minute to avoid the overheating of the pump.

Esempio di ordinazione in codice / Example of ordering code

1SP	A	2.5	D	SAE AA	-	10	GG0	VLP-I	(N)
VLP-I	Coperchio con VPL a scarico interno Cover with VPL at internal exhaust							VLP-I	
(N)	Tipo di molla / Spring type							B - N - G - R (vedi tabella / See table)	

		Tipo di molla / Spring type			
		B	N	G	R
		molla bianca white spring	molla nera black spring	molla gialla yellow spring	molla rossa red spring
Campi di taratura* Calibration fields*	[bar] (psi)	30 ÷ 80 (435 ÷ 1160)	81 ÷ 200 (1175 ÷ 2900)	201 ÷ 300 (2915 ÷ 4350)	301 ÷ 400 (4365 ÷ 5800)

* In caso di omissione del valore di taratura, esso sarà inteso standard (molla nera con taratura 120 bar).

* Without setting request, it will be considered standard (black spring: 1740 psi).

**POMPE GRUPPO
PUMPS GROUP**

2

Standard

**Flangia e coperchio in Alluminio
Flange and cover in Aluminium**

Dati tecnici / Technical data

Grandezza Size	Cilindrata Displacement [cm ³ /rev] (in ³ /rev)	Pressione max. d'esercizio Max. working pressure			Velocità max. Max. speed [g/min] (rpm)	Portata max. Max. flow [l/min] (Gal/min)	Velocità min. Min. speed [g/min] (rpm)	Portata min. Min. flow [l/min] (Gal/min)	Dimensioni Dimensions		Massa Mass [Kg] (lbs)	Rendimento volumetrico min. Min. volumetric efficiency %
		P1 [bar] (PSI)	P2 [bar] (PSI)	P3 [bar] (PSI)					A [mm] (inch)	B [mm] (inch)		
2SP A4	4 (0.24)	250 (3625)	270 (3915)	290 (4205)	4000	16 (4.23)	500	1.9 (0.50)	44.4 (1.748)	93 (3.661)	2.30 (5.07)	95*
2SP A6	6 (0.37)	250 (3625)	270 (3915)	290 (4205)	4000	24 (6.34)	500	2.85 (0.75)	46 (1.811)	96.3 (3.791)	2.45 (5.40)	
2SP A8	8.5 (0.52)	250 (3625)	270 (3915)	290 (4205)	3500	29.7 (7.85)	500	4.03 (1.06)	48.1 (1.894)	100.5 (3.957)	2.60 (5.73)	
2SP A11	11 (0.67)	250 (3625)	270 (3915)	290 (4205)	3500	38.5 (10.17)	500	5.22 (1.38)	50.2 (1.976)	104.6 (4.118)	2.70 (5.95)	
2SP A14	14 (0.85)	250 (3625)	270 (3915)	290 (4205)	3500	49 (12.95)	500	6.65 (1.76)	52.7 (2.075)	109.6 (4.315)	2.80 (6.17)	
2SP A16	16.5 (1.01)	230 (3335)	240 (3480)	250 (3625)	3500	57.7 (15.24)	500	7.83 (2.07)	54.8 (2.157)	113.8 (4.480)	2.95 (6.51)	
2SP A19	19.5 (1.19)	210 (3045)	220 (3190)	230 (3335)	3300	64.3 (16.99)	500	9.26 (2.45)	57.3 (2.256)	118.8 (4.677)	3.10 (6.84)	
2SP A22	22.5 (1.37)	190 (2755)	200 (2900)	210 (3045)	2800	63 (16.64)	500	10.68 (2.82)	59.8 (2.354)	123.8 (4.874)	3.25 (7.17)	
2SP A26	26 (1.59)	170 (2465)	180 (2610)	190 (2755)	2500	65 (17.17)	500	12.35 (3.26)	62.7 (2.469)	129.6 (5.102)	3.40 (7.50)	

* (Valori rilevati in fase di collaudo a 1500 giri/min / Value collected during the testing at 1500 rpm)

Esempio di ordinazione in codice / Example of ordering code

2SP	A	14	D	(H)	-	10	G	(VT)
------------	----------	-----------	----------	------------	----------	-----------	----------	-------------

2SP	Tipo pompa / Pump type	vedi tabella / see table
A	Flangia e coperchio / Flange and cover	A = Alluminio / Aluminium
14	Cilindrata / Displacement	vedi tabella / see table
D	Rotazione destra / Clockwise rotation	D = Rotazione destra / Clockwise rotation S = Rotazione sinistra / Anticlockwise rotation
— ⁽¹⁾	Tipo flangia / Flange type	
(H)	Anello di rinforzo per piccola pressione in aspirazione Stiffening seal for low suction pressure	(a richiesta / optional)
—		
10	Tipo albero / Shaft type	10 - 11 - 12 - 13 - 14 - 15 - 16
G	Tipo connessioni / Connections type	G - N - T - M - U - W - F
(VT)	Opzioni / Optional	(VT) Guarnizione in Viton (a richiesta) Viton seals (optional) VLP-I (N) - VLP-E (N) Valvola limitatrice di pressione (pag. A-49) Pressure relief valve (page A-49)

⁽¹⁾ Non è necessario indicare la flangia STANDARD / It is not necessary indicate STANDARD flange

Conn Connessioni / Connections

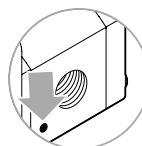
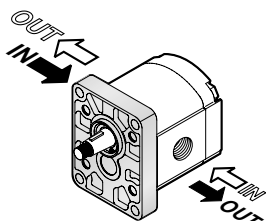
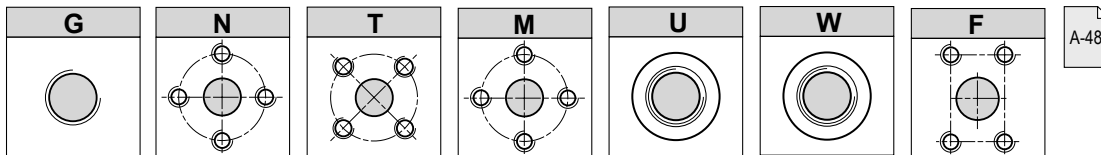

Il segno sul corpo indica il lato aspirazione per le pompe.
The sign on the body identify the suction side for the pumps.

Rotazione / Rotation	
D	S

Flangia e coperchio in Alluminio
Flange and cover in Aluminium

Standard

POMPE GRUPPO
PUMPS GROUP

2

Dimensioni / Dimensions

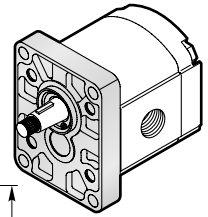
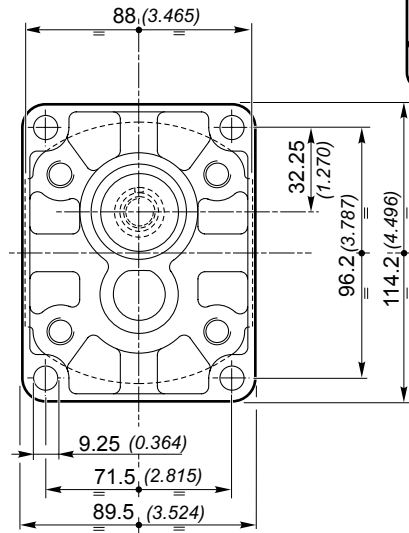
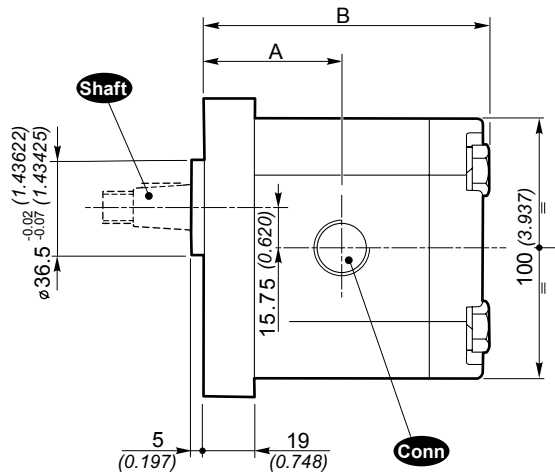

Shaft Alberi disponibili / Available shafts

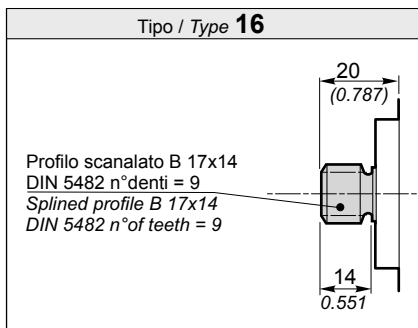
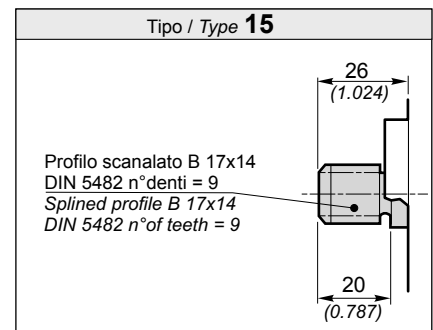
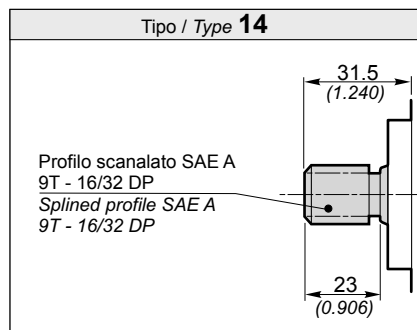
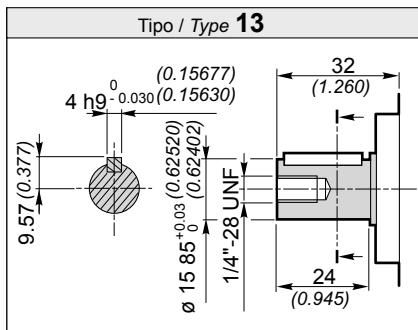
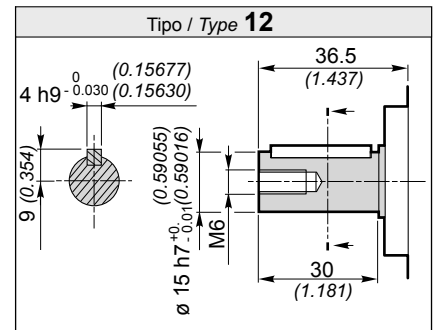
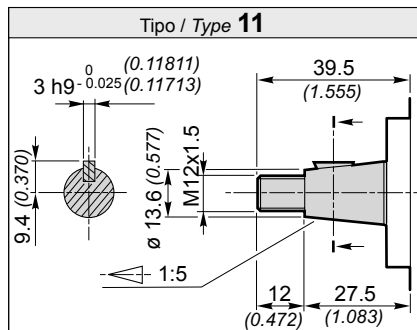
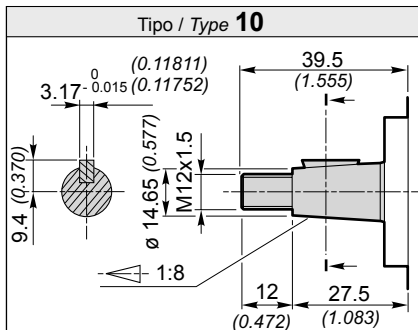

**POMPE GRUPPO
PUMPS GROUP**

2

Standard

**Flangia e coperchio in Ghisa
Flange and cover in Cast iron**

Dati tecnici / Technical data

Grandezza Size	Cilindrata Displacement [cm ³ /rev] (in ³ /rev)	Pressione max. d'esercizio Max. working pressure			Velocità max. Max. speed [g/min] (rpm)	Portata max. Max. flow [l/min] (Gal/min)	Velocità min. Min. speed [g/min] (rpm)	Portata min. Min. flow [l/min] (Gal/min)	Dimensioni Dimensions		Massa Mass [Kg] (lbs)	Rendimento volumetrico min. Min. volumetric efficiency %
		P1 [bar] (PSI)	P2 [bar] (PSI)	P3 [bar] (PSI)					A [mm] (inch)	B [mm] (inch)		
2SP G4	4 (0.24)	280 (4060)	300 (4350)	320 (4640)	4000	16 (4.23)	500	1.9 (0.50)	44.4 (1.748)	93 (3.661)	3.40 (7.50)	95*
2SP G6	6 (0.37)	280 (4060)	300 (4350)	320 (4640)	4000	24 (6.34)	500	2.85 (0.75)	46 (1.811)	96.3 (3.791)	3.55 (7.83)	
2SP G8	8.5 (0.52)	280 (4060)	300 (4350)	320 (4640)	3500	29.7 (7.85)	500	4.03 (1.06)	48.1 (1.894)	100.5 (4.118)	3.70 (8.16)	
2SP G11	11 (0.67)	280 (4060)	300 (4350)	320 (4640)	3500	38.5 (10.17)	500	5.22 (1.38)	50.2 (1.976)	104.6 (4.118)	3.80 (8.38)	
2SP G14	14 (0.85)	270 (3915)	280 (4060)	290 (4205)	3500	49 (12.95)	500	6.65 (1.76)	52.7 (2.075)	109.6 (4.315)	3.90 (8.60)	
2SP G16	16.5 (1.01)	230 (3335)	240 (3480)	250 (3625)	3500	57.7 (15.24)	500	7.83 (2.07)	54.8 (2.157)	113.8 (4.480)	4.05 (8.93)	
2SP G19	19.5 (1.19)	210 (3045)	220 (3190)	230 (3335)	3300	64.3 (16.99)	500	9.26 (2.45)	57.3 (2.256)	118.8 (4.677)	4.20 (9.26)	
2SP G22	22.5 (1.37)	190 (2755)	200 (2900)	210 (3045)	2800	63 (16.64)	500	10.68 (2.82)	59.8 (2.354)	123.8 (4.874)	4.35 (9.59)	
2SP G26	26 (1.59)	170 (2465)	180 (2610)	190 (2755)	2500	65 (17.17)	500	12.35 (3.26)	62.7 (2.469)	129.6 (5.102)	4.50 (9.92)	

* (Valori rilevati in fase di collaudo a 1500 giri/min / Value collected during the testing at 1500 rpm)

Esempio di ordinazione in codice / Example of ordering code

2SP	G	14	D	(H)	-	10	G	(VT)
------------	----------	-----------	----------	------------	----------	-----------	----------	-------------

2SP	Tipo pompa / Pump type	vedi tabella / see table
G	Flangia e coperchio / Flange and cover	G = Ghisa / Cast iron
14	Cilindrata / Displacement	vedi tabella / see table
D	Rotazione destra / Clockwise rotation	D = Rotazione destra / Clockwise rotation S = Rotazione sinistra / Anticlockwise rotation
— ⁽¹⁾	Tipo flangia / Flange type	
(H)	Anello di rinforzo per piccola pressione in aspirazione Stiffening seal for low suction pressure	(a richiesta / optional)
—		
10	Tipo albero / Shaft type	10 - 11 - 12 - 13 - 14 - 15 - 16
G	Tipo connessioni / Connections type	G - N - T - M - U - W - F
(VT)	Opzioni / Optional	(VT) Guarnizione in Viton (a richiesta) Viton seals (optional) VLP-I (N) - VLP-E (N) Valvola limitatrice di pressione (pag. A-49) Pressure relief valve (page A-49)

⁽¹⁾ Non è necessario indicare la flangia STANDARD / It is not necessary indicate STANDARD flange

Conn Connessioni / Connections

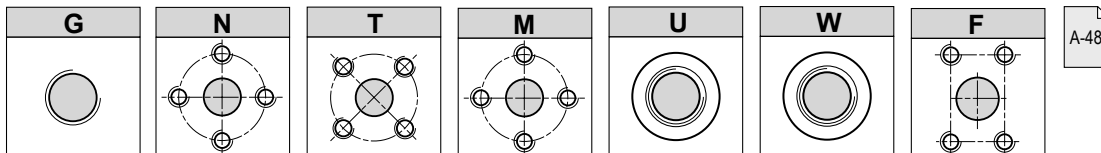

A-48

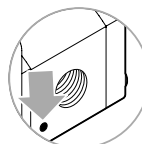
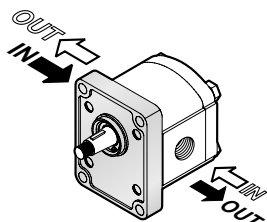

Il segno sul corpo indica il **lato aspirazione** per le pompe.
The sign on the body identify the **suction side** for the pumps.

Rotazione / Rotation	
D	S

Flangia e coperchio in Ghisa
Flange and cover in Cast iron

Standard

POMPE GRUPPO
PUMPS GROUP

2

Dimensioni / Dimensions

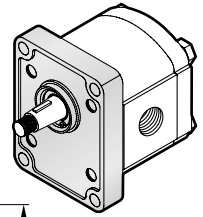
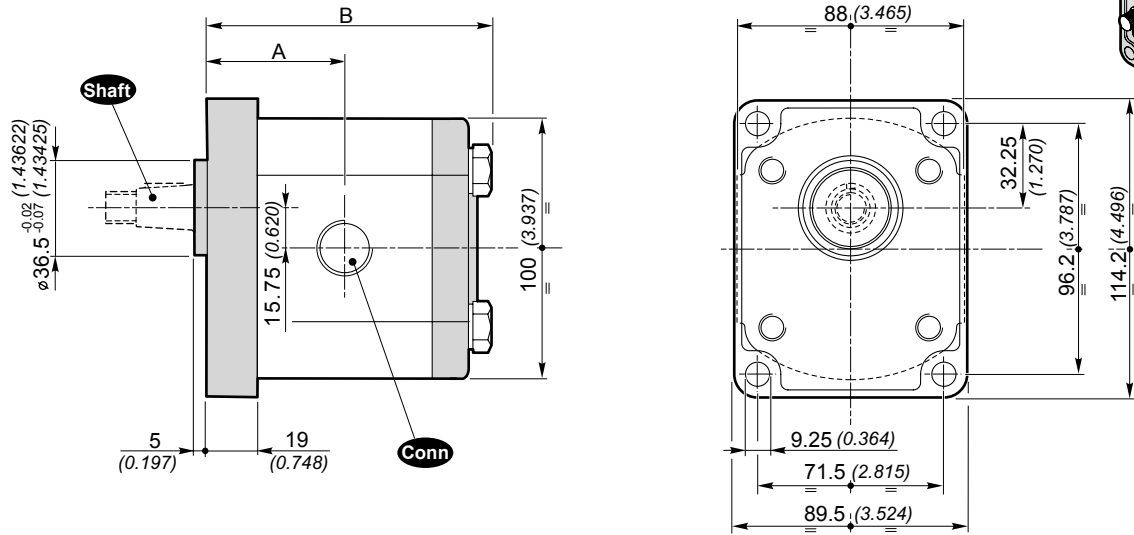

Shaft Alberi disponibili / Available shafts

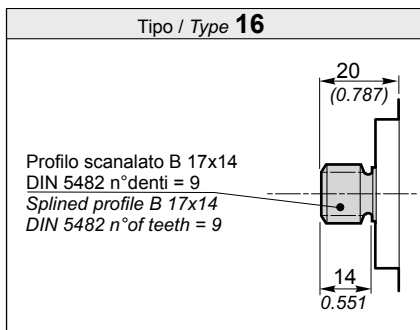
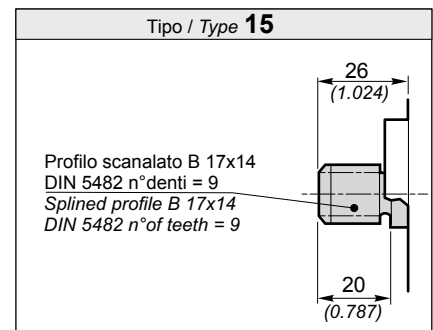
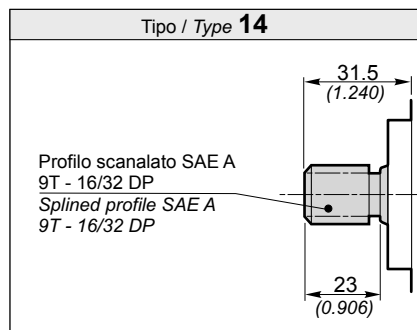
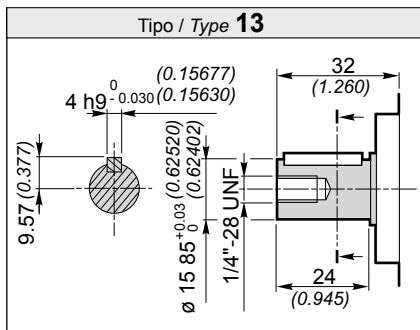
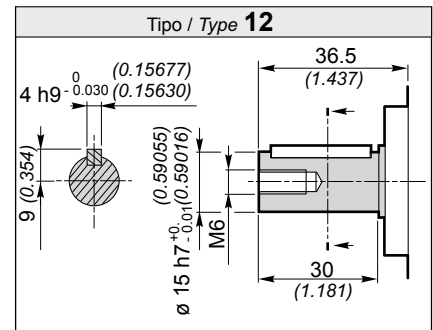
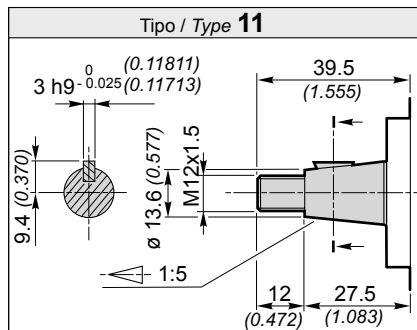
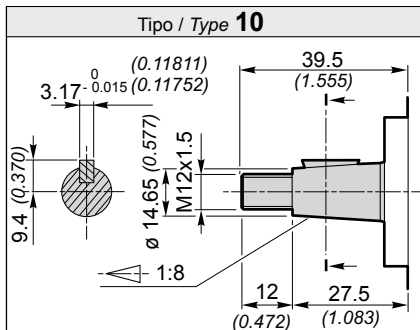

**POMPE GRUPPO
PUMPS GROUP**

2

SAE A , SAE A-OR

**Flangia e coperchio in Alluminio
Flange and cover in Aluminium**

Dati tecnici / Technical data

Grandezza Size	Cilindrata Displacement [cm³/rev] (in³/rev)	Pressione max. d'esercizio Max. working pressure			Velocità max. Max. speed [g/min] (rpm)	Portata max. Max. flow [l/min] (Gal/min)	Velocità min. Min. speed [g/min] (rpm)	Portata min. Min. flow [l/min] (Gal/min)	Dimensioni Dimensions		Massa Mass [Kg] (lbs)	Rendimento volumetrico min. Min. volumetric efficiency %
		P1 [bar] (PSI)	P2 [bar] (PSI)	P3 [bar] (PSI)					A [mm] (inch)	B [mm] (inch)		
2SP A4	4 (0.24)	250 (3625)	270 (3915)	290 (4205)	4000	16 (4.23)	500	1.9 (0.50)	44.4 (1.748)	93 (3.661)	2.30 (5.07)	95*
2SP A6	6 (0.37)	250 (3625)	270 (3915)	290 (4205)	4000	24 (6.34)	500	2.85 (0.75)	46 (1.811)	96.3 (3.791)	2.45 (5.40)	
2SP A8	8.5 (0.52)	250 (3625)	270 (3915)	290 (4205)	3500	29.7 (7.85)	500	4.03 (1.06)	48.1 (1.894)	100.5 (3.957)	2.60 (5.73)	
2SP A11	11 (0.67)	250 (3625)	270 (3915)	290 (4205)	3500	38.5 (10.17)	500	5.22 (1.38)	50.2 (1.976)	104.6 (4.118)	2.70 (5.95)	
2SP A14	14 (0.85)	250 (3625)	270 (3915)	290 (4205)	3500	49 (12.95)	500	6.65 (1.76)	52.7 (2.075)	109.6 (4.315)	2.80 (6.17)	
2SP A16	16.5 (1.01)	230 (3335)	240 (3480)	250 (3625)	3500	57.7 (15.24)	500	7.83 (2.07)	54.8 (2.157)	113.8 (4.480)	2.95 (6.51)	
2SP A19	19.5 (1.19)	210 (3045)	220 (3190)	230 (3335)	3300	64.3 (16.99)	500	9.26 (2.45)	57.3 (2.256)	118.8 (4.677)	3.10 (6.84)	
2SP A22	22.5 (1.37)	190 (2755)	200 (2900)	210 (3045)	2800	63 (16.64)	500	10.68 (2.82)	59.8 (2.354)	123.8 (4.874)	3.25 (7.17)	
2SP A26	26 (1.59)	170 (2465)	180 (2610)	190 (2755)	2500	65 (17.17)	500	12.35 (3.26)	62.7 (2.469)	129.6 (5.102)	3.40 (7.50)	

* (Valori rilevati in fase di collaudo a 1500 giri/min / Value collected during the testing at 1500 rpm)

Esempio di ordinazione in codice / Example of ordering code

2SP	A	14	D	SAE A	(H)	-	10	G	(VT)
------------	----------	-----------	----------	--------------	------------	----------	-----------	----------	-------------

2SP	Tipo pompa / Pump type	vedi tabella / see table
A	Flangia e coperchio / Flange and cover	A = Alluminio / Aluminium
14	Cilindrata / Displacement	vedi tabella / see table
D	Rotazione destra / Clockwise rotation	D = Rotazione destra / Clockwise rotation S = Rotazione sinistra / Anticlockwise rotation
SAE A	Tipo flangia / Flange type	SAE A - SAE A-OR
(H)	Anello di rinforzo per piccola pressione in aspirazione Stiffening seal for low suction pressure	(a richiesta / (optional))
-		
10	Tipo albero / Shaft type	10 - 11 - 12 - 13 - 14 - 15 - 16
G	Tipo connessioni / Connections type	G - N - T - M - U - W - F
(VT)	Opzioni / Optional	(VT) Guarnizione in Viton (a richiesta) Viton seals (optional) VLP-I (N) - VLP-E (N) Valvola limitatrice di pressione (pag. A-49) Pressure relief valve (page A-49)

Conn Connessioni / Connections

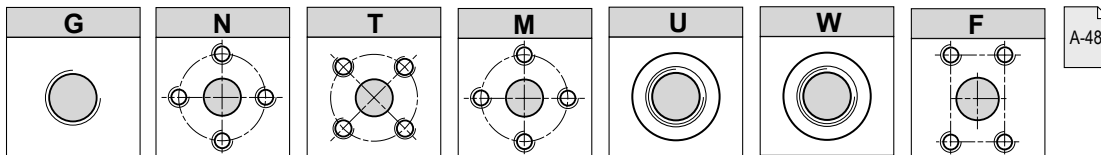

A-48

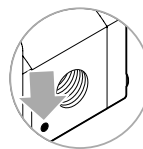
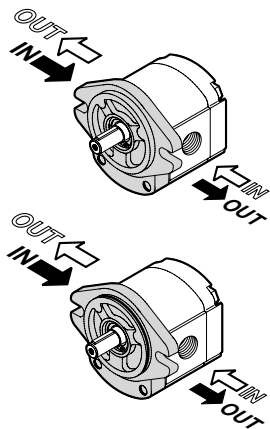

Il segno sul corpo indica il lato aspirazione per le pompe.
The sign on the body identify the suction side for the pumps.

Rotazione / Rotation	
D	S

Flangia e coperchio in Alluminio
Flange and cover in Aluminium

SAE A , SAE A-OR

POMPE GRUPPO
PUMPS GROUP

2

Dimensioni / Dimensions

SAE A-OR

SAE A

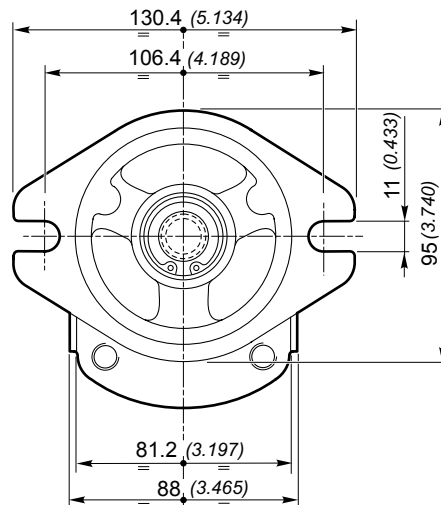
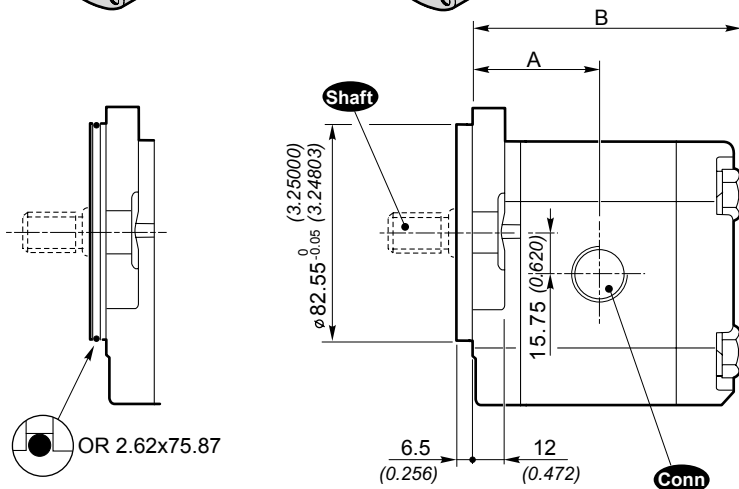
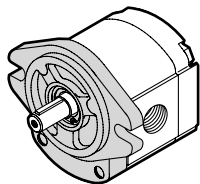
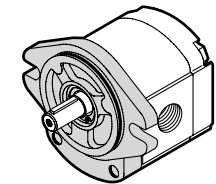

Shaft Alberi disponibili / Available shafts

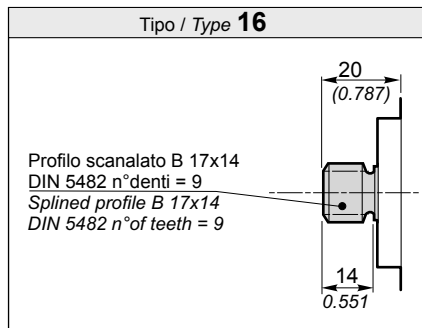
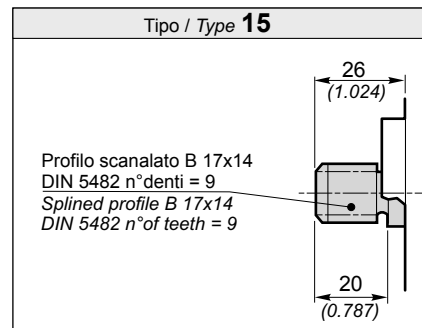
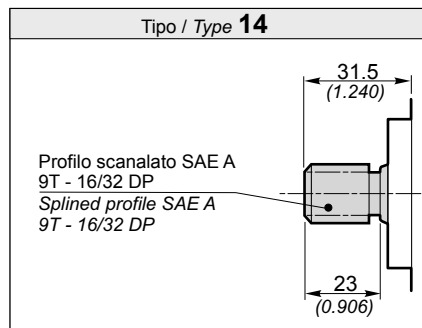
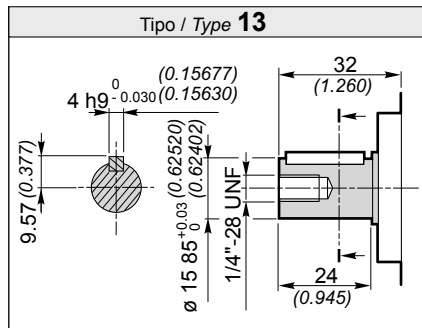
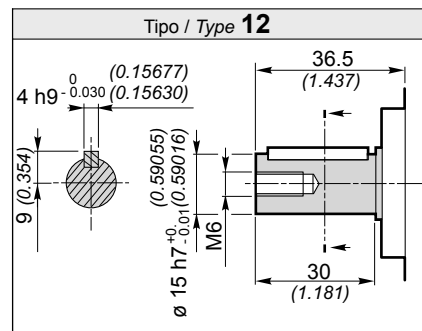
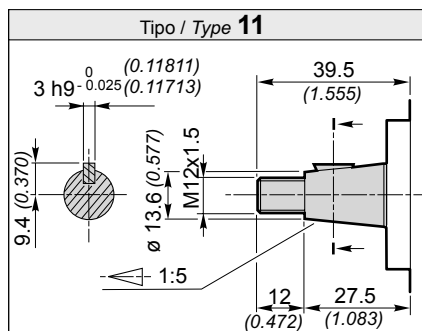
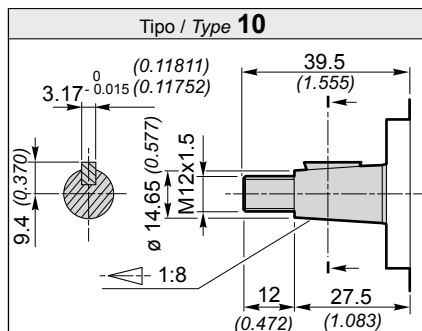

**POMPE GRUPPO
PUMPS GROUP**

2

SAE A , SAE A-OR

**Flangia e coperchio in Ghisa
Flange and cover in Cast iron**

Dati tecnici / Technical data

Grandezza Size	Cilindrata Displacement [cm ³ /rev] (in ³ /rev)	Pressione max. d'esercizio Max. working pressure			Velocità max. Max. speed [g/min] (rpm)	Portata max. Max. flow [l/min] (Gal/min)	Velocità min. Min. speed [g/min] (rpm)	Portata min. Min. flow [l/min] (Gal/min)	Dimensioni Dimensions		Massa Mass [Kg] (lbs)	Rendimento volumetrico min. Min. volumetric efficiency %
		P1 [bar] (PSI)	P2 [bar] (PSI)	P3 [bar] (PSI)					A [mm] (inch)	B [mm] (inch)		
2SP G4	4 (0.24)	280 (4060)	300 (4350)	320 (4640)	4000	16 (4.23)	500	1.9 (0.50)	44.4 (1.748)	93 (3.661)	3.40 (7.50)	95*
2SP G6	6 (0.37)	280 (4060)	300 (4350)	320 (4640)	4000	24 (6.34)	500	2.85 (0.75)	46 (1.811)	96.3 (3.791)	3.55 (7.83)	
2SP G8	8.5 (0.52)	280 (4060)	300 (4350)	320 (4640)	3500	29.7 (7.85)	500	4.03 (1.06)	48.1 (1.894)	100.5 (3.957)	3.70 (8.16)	
2SP G11	11 (0.67)	280 (4060)	300 (4350)	320 (4640)	3500	38.5 (10.17)	500	5.22 (1.38)	50.2 (1.976)	104.6 (4.118)	3.80 (8.38)	
2SP G14	14 (0.85)	270 (3915)	280 (4060)	290 (4205)	3500	49 (12.95)	500	6.65 (1.76)	52.7 (2.075)	109.6 (4.315)	3.90 (8.60)	
2SP G16	16.5 (1.01)	230 (3335)	240 (3480)	250 (3625)	3500	57.7 (15.24)	500	7.83 (2.07)	54.8 (2.157)	113.8 (4.480)	4.05 (8.93)	
2SP G19	19.5 (1.19)	210 (3045)	220 (3190)	230 (3335)	3300	64.3 (16.99)	500	9.26 (2.45)	57.3 (2.256)	118.8 (4.677)	4.20 (9.26)	
2SP G22	22.5 (1.37)	190 (2755)	200 (2900)	210 (3045)	2800	63 (16.64)	500	10.68 (2.82)	59.8 (2.354)	123.8 (4.874)	4.35 (9.59)	
2SP G26	26 (1.59)	170 (2465)	180 (2610)	190 (2755)	2500	65 (17.17)	500	12.35 (3.26)	62.7 (2.469)	129.6 (5.102)	4.50 (9.92)	

* (Valori rilevati in fase di collaudo a 1500 giri/min / Value collected during the testing at 1500 rpm)

Esempio di ordinazione in codice / Example of ordering code

2SP G 14 D SAE A (H) - 14 G (VT)

2SP	Tipo pompa / Pump type	vedi tabella / see table
G	Flangia e coperchio / Flange and cover	G = Ghisa / Cast iron
14	Cilindrata (vedi tabella) / Displacement (see table)	vedi tabella / see table
D	Rotazione destra / Clockwise rotation	D = Rotazione destra / Clockwise rotation S = Rotazione sinistra / Anticlockwise rotation
SAE A	Tipo flangia / Flange type	SAE A - SAE A-OR
(H)	Anello di rinforzo per piccola pressione in aspirazione (a richiesta) Stiffening seal for low suction pressure (optional)	(a richiesta / (optional))
-		
14	Tipo albero / Shaft type	10 - 11 - 12 - 13 - 14 - 15 - 16
G	Tipo connessioni / Connections type	G - N - T - M - U - W - F
(VT)	Opzioni / Optional	(VT) Guarnizione in Viton (a richiesta) Viton seals (optional) VLP-I (N) - VLP-E (N) Valvola limitatrice di pressione (pag. A-49) Pressure relief valve (page A-49)

Conn Connessioni / Connections

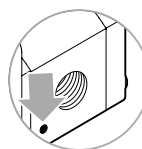
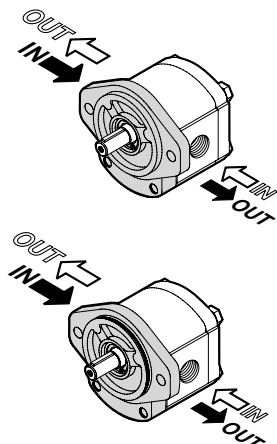
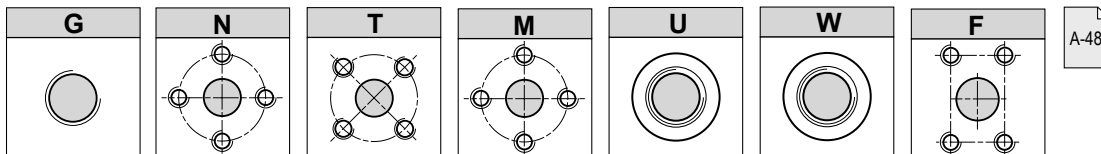

Il segno sul corpo indica il **lato aspirazione** per le pompe.
The sign on the body identify the **suction side** for the pumps.

Rotazione / Rotation	
D	S

Flangia e coperchio in Ghisa
Flange and cover in Cast iron

SAE A , SAE A-OR

POMPE GRUPPO
PUMPS GROUP

2

Dimensioni / Dimensions

SAE A-OR

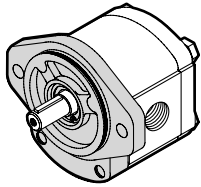

SAE A

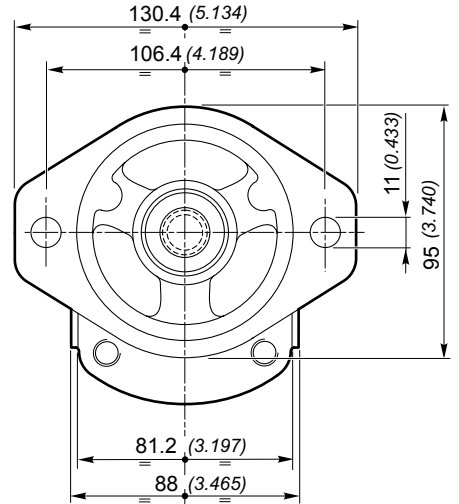
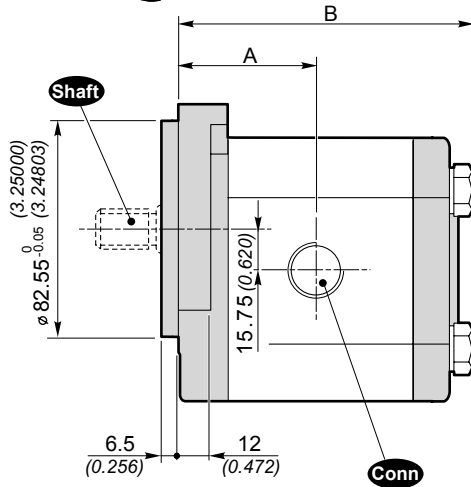
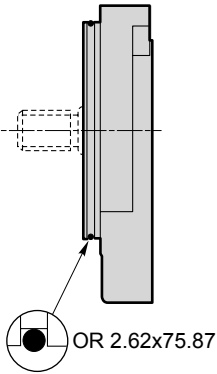
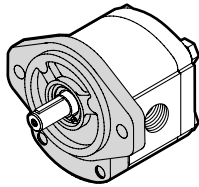

Shaft Alberi disponibili / Available shafts

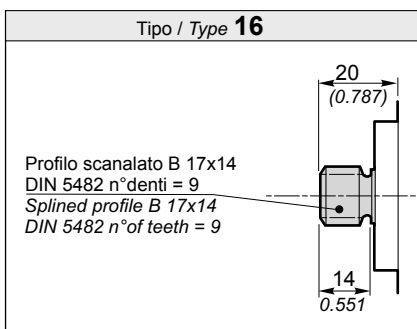
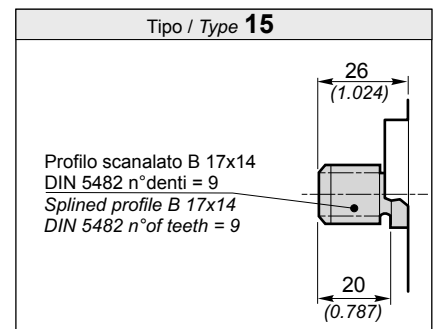
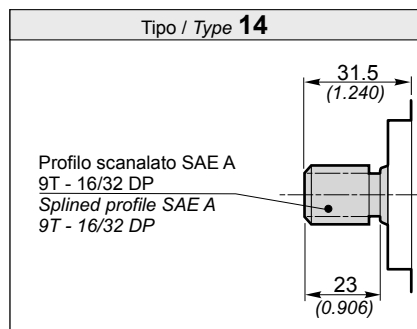
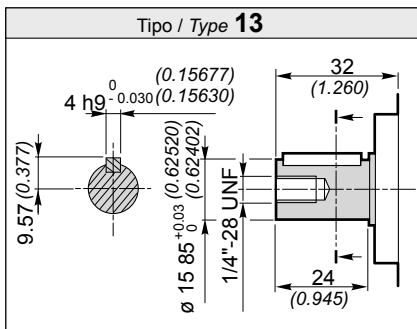
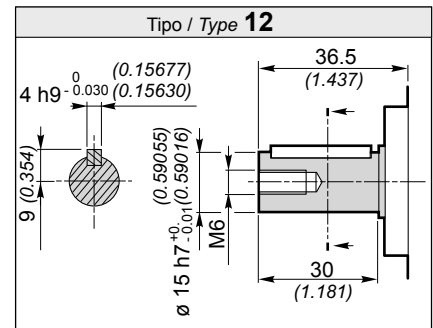
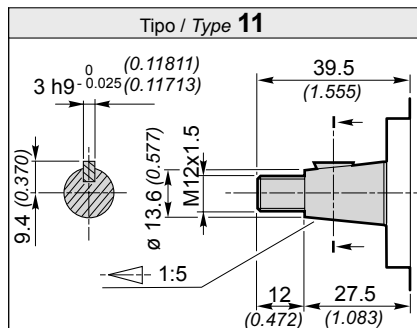
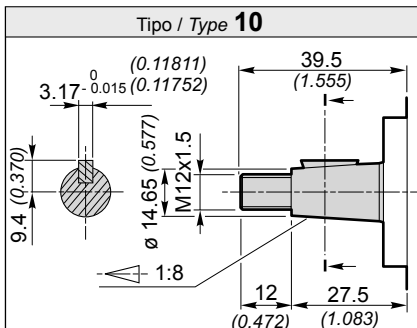

**POMPE GRUPPO
PUMPS GROUP**

2

B80C

Dati tecnici / Technical data

Grandezza Size	Cilindrata Displacement [cm ³ /rev] (in ³ /rev)	Pressione max. d'esercizio Max. working pressure			Velocità max. Max. speed [g/min] (rpm)	Portata max. Max. flow [l/min] (Gal/min)	Velocità min. Min. speed [g/min] (rpm)	Portata min. Min. flow [l/min] (Gal/min)	Dimensioni Dimensions		Massa Mass [Kg] (lbs)	Rendimento volumetrico min. Min. volumetric efficiency %
		P1 [bar] (PSI)	P2 [bar] (PSI)	P3 [bar] (PSI)					A [mm] (inch)	B [mm] (inch)		
2SP A4	4 (0.24)	250 (3625)	270 (3915)	290 (4205)	4000	16 (4.23)	500	1.9 (0.50)	46.4 1.827	95 3.740	2.30 (5.07)	95*
2SP A6	6 (0.37)	250 (3625)	270 (3915)	290 (4205)	4000	24 (6.34)	500	2.85 (0.75)	48 1.890	98.3 3.870	2.45 (5.40)	
2SP A8	8.5 (0.52)	250 (3625)	270 (3915)	290 (4205)	3500	29.7 (7.85)	500	4.03 (1.06)	50.1 1.972	102.5 4.035	2.60 (5.73)	
2SP A11	11 (0.67)	250 (3625)	270 (3915)	290 (4205)	3500	38.5 (10.17)	500	5.22 (1.38)	52.2 2.055	106.6 4.197	2.70 (5.95)	
2SP A14	14 (0.85)	250 (3625)	270 (3915)	290 (4205)	3500	49 (12.95)	500	6.65 (1.76)	54.7 2.154	111.6 4.394	2.80 (6.17)	
2SP A16	16.5 (1.01)	230 (3335)	240 (3480)	250 (3625)	3500	57.7 (15.24)	500	7.83 (2.07)	56.8 2.236	115.8 4.559	2.95 (6.51)	
2SP A19	19.5 (1.19)	210 (3045)	220 (3190)	230 (3335)	3300	64.3 (16.99)	500	9.26 (2.45)	59.3 2.335	120.8 4.756	3.10 (6.84)	
2SP A22	22.5 (1.37)	190 (2755)	200 (2900)	210 (3045)	2800	63 (16.64)	500	10.68 (2.82)	61.8 2.433	125.8 4.953	3.25 (7.17)	
2SP A26	26 (1.59)	170 (2465)	180 (2610)	190 (2755)	2500	65 (17.17)	500	12.35 (3.26)	64.7 2.547	131.6 5.181	3.40 (7.50)	

* (Valori rilevati in fase di collaudo a 1500 giri/min / Value collected during the testing at 1500 rpm)

Esempio di ordinazione in codice / Example of ordering code

2SP | A | 14 | D | (H) | - | 10 | G | (VT)

2SP	Tipo pompa / Pump type	vedi tabella / see table
A	Flangia e coperchio / Flange and cover	A = Alluminio / Aluminium
14	Cilindrata / Displacement	vedi tabella / see table
D	Rotazione destra / Clockwise rotation	D = Rotazione destra / Clockwise rotation S = Rotazione sinistra / Anticlockwise rotation
	Tipo flangia / Flange type	B80C
(H)	Anello di rinforzo per piccola pressione in aspirazione Stiffening seal for low suction pressure	(a richiesta / optional)
-		
10	Tipo albero / Shaft type	10 - 11 - 12 - 13 - 14 - 15 - 16
G	Tipo connessioni / Connections type	G - N - T - M - U - W - F
(VT)	Opzioni / Optional	(VT) Guarnizione in Viton (a richiesta) Viton seals (optional) VLP-I (N) - VLP-E (N) Valvola limitatrice di pressione (pag. A-49) Pressure relief valve (page A-49)

Conn Connessioni / Connections

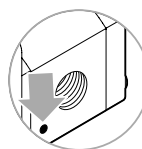
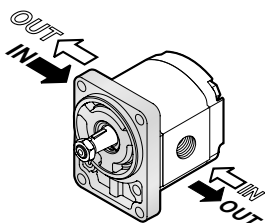
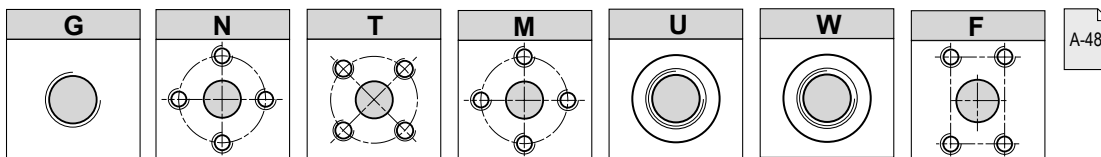

Il segno sul corpo indica il **lato aspirazione** per le pompe.
The sign on the body identify the **suction side** for the pumps.

Rotazione / Rotation	
D	S

B80C **POMPE GRUPPO**
PUMPS GROUP **2**

Dimensioni / Dimensions

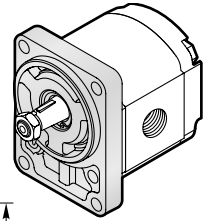
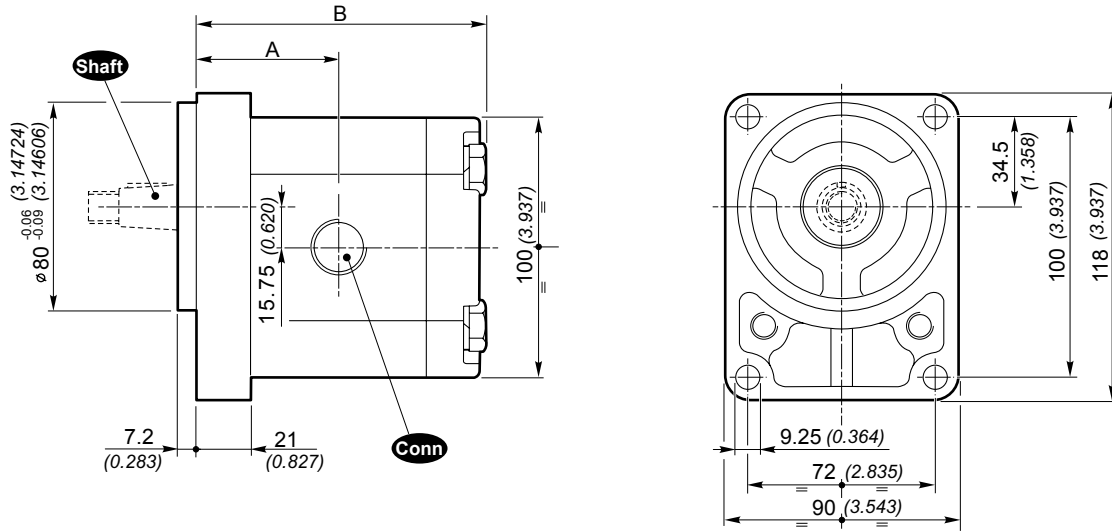

Shaft Alberi disponibili / Available shafts

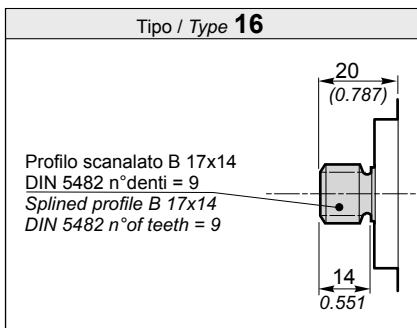
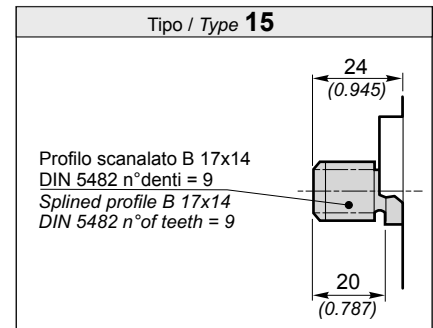
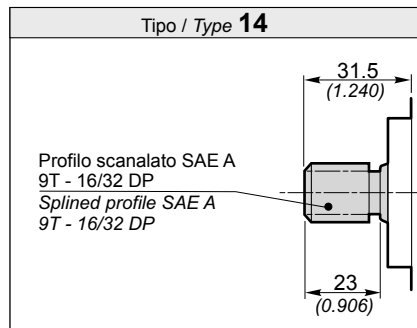
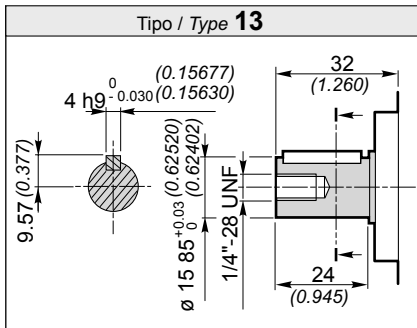
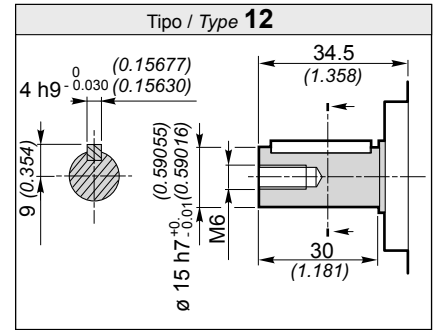
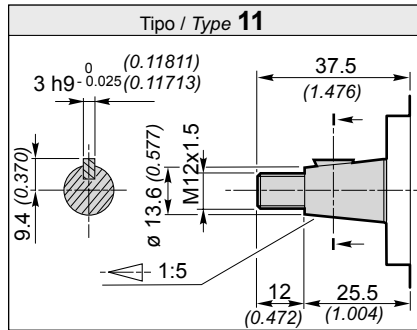
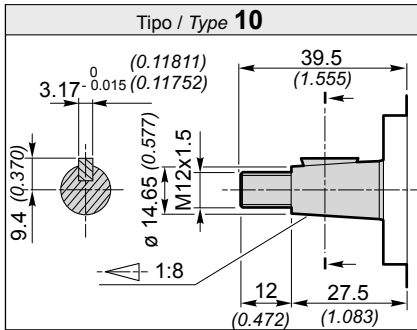

**POMPE GRUPPO
PUMPS GROUP**

2

B50C

Dati tecnici / Technical data

Grandezza Size	Cilindrata Displacement [cm ³ /rev] (in ³ /rev)	Pressione max. d'esercizio Max. working pressure			Velocità max. Max. speed [g/min] (rpm)	Portata max. Max. flow [l/min] (Gal/min)	Velocità min. Min. speed [g/min] (rpm)	Portata min. Min. flow [l/min] (Gal/min)	Dimensioni Dimensions				Massa Mass [Kg] (lbs)	Rendimento volumetrico min. Min. volumetric efficiency %
		P1 [bar] (PSI)	P2 [bar] (PSI)	P3 [bar] (PSI)					A [mm] (inch)	B [mm] (inch)	C [mm] (inch)	L ¹ [mm] (inch)		
2SP A4	4 (0.24)	250 (3625)	270 (3915)	290 (4205)	4000	16 (4.23)	500	1.9 (0.50)	44.4 (1.748)	93 (3.661)	84 (3.307)	105 (4.134)	2.30 (5.07)	95*
2SP A6	6 (0.37)	250 (3625)	270 (3915)	290 (4205)	4000	24 (6.34)	500	2.85 (0.75)	46 (1.811)	96.3 (3.791)	87.3 (3.437)	105 (4.134)	2.45 (5.40)	
2SP A8	8.5 (0.52)	250 (3625)	270 (3915)	290 (4205)	3500	29.7 (7.85)	500	4.03 (1.06)	48.1 (1.894)	100.5 (3.957)	91.5 (3.602)	110 (4.331)	2.60 (5.73)	
2SP A11	11 (0.67)	250 (3625)	270 (3915)	290 (4205)	3500	38.5 (10.17)	500	5.22 (1.38)	50.2 (1.976)	104.6 (4.118)	95.6 (3.764)	115 (4.528)	2.70 (5.95)	
2SP A14	14 (0.85)	250 (3625)	270 (3915)	290 (4205)	3500	49 (12.95)	500	6.65 (1.76)	52.7 (2.075)	109.6 (4.315)	100.6 (3.961)	120 (4.724)	2.80 (6.17)	
2SP A16	16.5 (1.01)	230 (3335)	240 (3480)	250 (3625)	3500	57.7 (15.24)	500	7.83 (2.07)	54.8 (2.157)	113.8 (4.480)	104.8 (4.126)	125 (4.921)	2.95 (6.51)	
2SP A19	19.5 (1.19)	210 (3045)	220 (3190)	230 (3335)	3300	64.3 (16.99)	500	9.26 (2.45)	57.3 (2.256)	118.8 (4.677)	109.8 (4.323)	130 (5.118)	3.10 (6.84)	
2SP A22	22.5 (1.37)	190 (2755)	200 (2900)	210 (3045)	2800	63 (16.64)	500	10.68 (2.82)	59.8 (2.354)	123.8 (4.874)	114.8 (4.520)	135 (5.315)	3.25 (7.17)	
2SP A26	26 (1.59)	170 (2465)	180 (2610)	190 (2755)	2500	65 (17.17)	500	12.35 (3.26)	62.7 (2.469)	129.6 (5.102)	120.6 (4.748)	140 (5.512)	3.40 (7.50)	

* (Valori rilevati in fase di collaudo a 1500 giri/min / Value collected during the testing at 1500 rpm)

Esempio di ordinazione in codice / Example of ordering code

2SP | A | 14 | D | (H) | - | 10 | G | (VT)

2SP	Tipo pompa / Pump type	vedi tabella / see table
A	Flangia e coperchio / Flange and cover	A = Alluminio / Aluminium
14	Cilindrata / Displacement	vedi tabella / see table
D	Rotazione destra / Clockwise rotation	D = Rotazione destra / Clockwise rotation S = Rotazione sinistra / Anticlockwise rotation
	Tipo flangia / Flange type	B50CX - B50CY
(H)	Anello di rinforzo per piccola pressione in aspirazione Stiffening seal for low suction pressure	(a richiesta / (optional))
-		
10	Tipo albero / Shaft type	10 - 11 - 12 - 13 - 14 - 15 - 16
G	Tipo connessioni / Connections type	G - N - T - M - U - W - F
(VT)	Opzioni / Optional	(VT) Guarnizione in Viton (a richiesta) Viton seals (optional) VLP-I (N) - VLP-E (N) Valvola limitatrice di pressione (pag. A-49) Pressure relief valve (page A-49)

Conn Connessioni / Connections

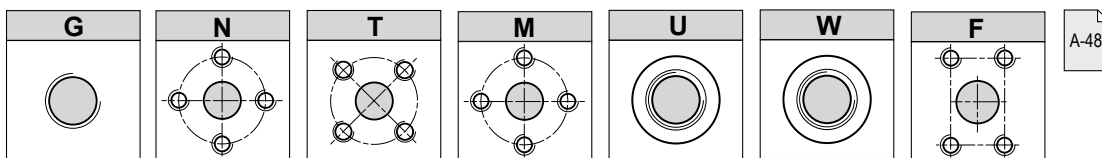

Versione
Version
B50CX

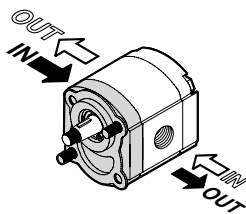

Versione
Version
B50CY

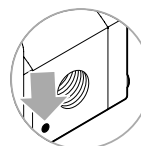
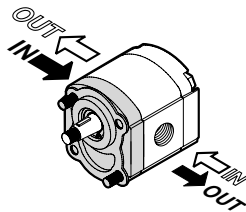

Il segno sul corpo indica il lato aspirazione per le pompe.
The sign on the body identify the suction side for the pumps.

Rotazione / Rotation	
D	S

B50C

POMPE GRUPPO
PUMPS GROUP

2

Dimensioni / Dimensions

Versione
Version
B50CX

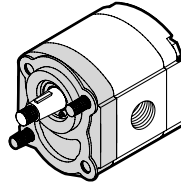

Versione
Version
B50CY

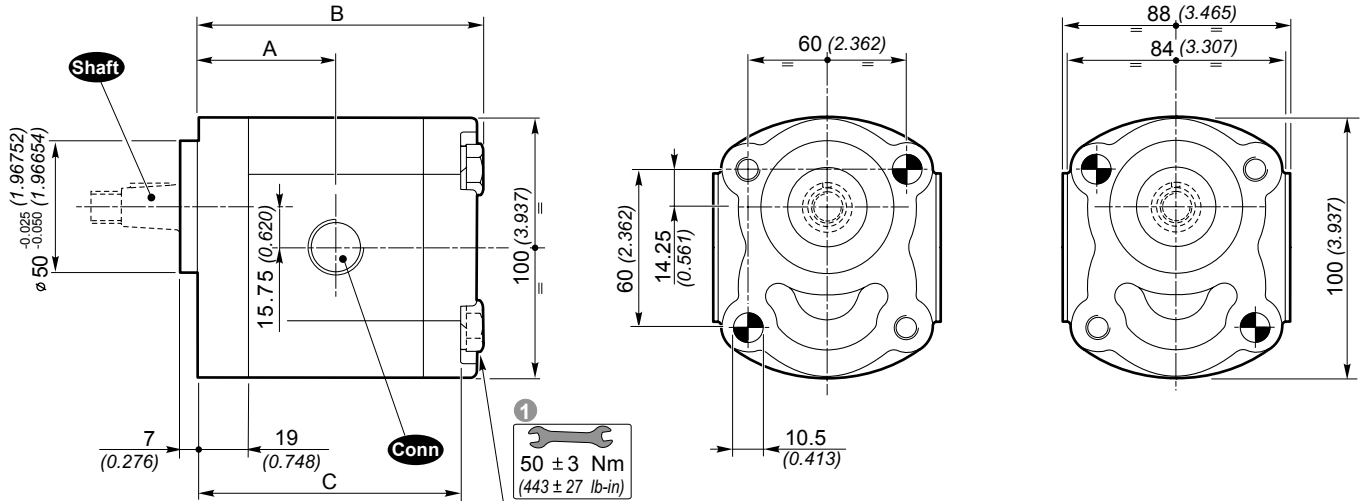
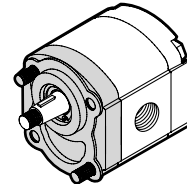

Shaft Alberi disponibili / Available shafts

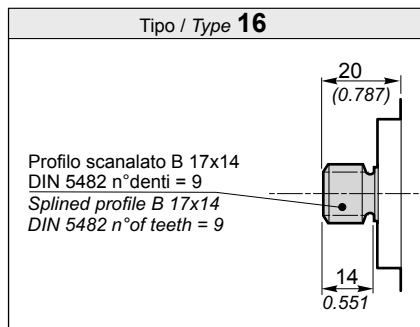
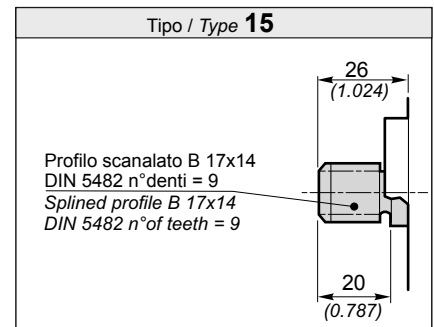
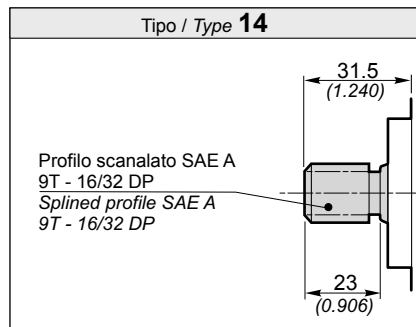
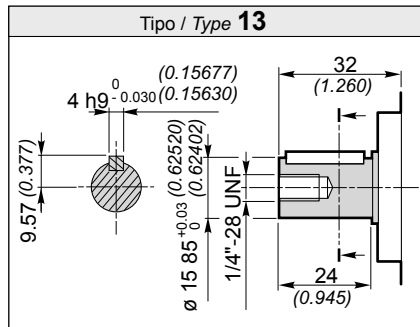
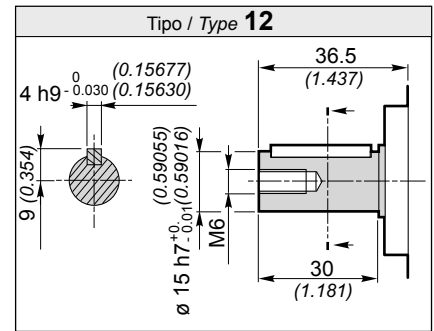
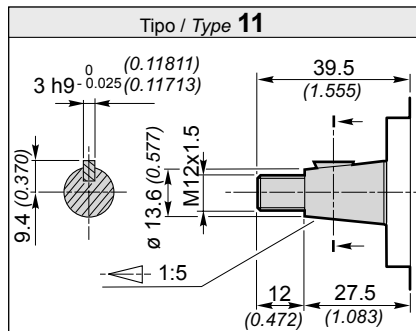
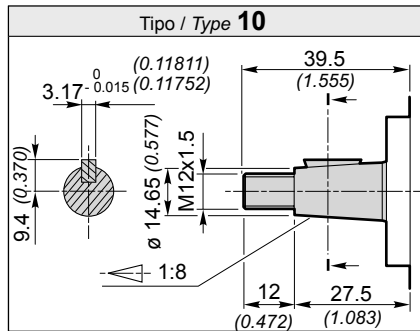

1 Coppia di serraggio viti: 50 ± 3 Nm. Utilizzare viti classe 10.9 - 12.9 UNI EN 20898/1.

Il fissaggio della pompa può essere effettuato con 2 viti prigioniere in materiale classe 10.9 - 12.9 preserrate a 40 ± 3 Nm.
Fissare la pompa mediante dadi autobloccanti con coppia di serraggio 50 ± 3 Nm.

1 Tightening torque of screws: 443 ± 27 lb-in. Use screws type 10.9 - 12.9 UNI EN 20898/1.

The assembling of the pump should be effected with 2 screw studs type 10.9 - 12.9 pre-tighten at 354 ± 27 lb-in.
Fix the pump by self-locking nuts with tightening torque 443 ± 27 lb-in.

Il Kit di viti per il fissaggio della pompa è da ordinare separatamente. Codice di ordinazione del Kit di fissaggio:

The screws kit for the pump assembling should be ordered separately. Ordering code of fixing Kit:

0029W + Lunghezza L (vedi tabella)
+ Length L (see table)

**POMPE GRUPPO
PUMPS GROUP**

2

E52C

Dati tecnici / Technical data

Grandezza Size	Cilindrata Displacement [cm ³ /rev] (in ³ /rev)	Pressione max. d'esercizio Max. working pressure			Velocità max. Max. speed [g/min] (rpm)	Portata max. Max. flow [l/min] (Gal/min)	Velocità min. Min. speed [g/min] (rpm)	Portata min. Min. flow [l/min] (Gal/min)	Dimensioni Dimensions				Massa Mass [Kg] (lbs)	Rendimento volumetrico min. Min. volumetric efficiency %
		P1 [bar] (PSI)	P2 [bar] (PSI)	P3 [bar] (PSI)					A [mm] (inch)	B [mm] (inch)	C [mm] (inch)	L ① [mm] (inch)		
2SP A4	4 (0.24)	250 (3625)	270 (3915)	290 (4205)	4000	16 (4.23)	500	1.9 (0.50)	41.7 (1.642)	90.3 (3.555)	81.3 (3.201)	100 (3.937)	2.30 (5.07)	95*
2SP A6	6 (0.37)	250 (3625)	270 (3915)	290 (4205)	4000	24 (6.34)	500	2.85 (0.75)	43.3 (1.705)	93.6 (3.685)	84.6 (3.331)	105 (4.134)	2.45 (5.40)	
2SP A8	8.5 (0.52)	250 (3625)	270 (3915)	290 (4205)	3500	29.7 (7.85)	500	4.03 (1.06)	45.4 (1.787)	97.8 (3.850)	88.8 (3.496)	110 (4.331)	2.60 (5.73)	
2SP A11	11 (0.67)	250 (3625)	270 (3915)	290 (4205)	3500	38.5 (10.17)	500	5.22 (1.38)	47.5 (1.870)	101.9 (4.012)	92.9 (3.657)	115 (4.528)	2.70 (5.95)	
2SP A14	14 (0.85)	250 (3625)	270 (3915)	290 (4205)	3500	49 (12.95)	500	6.65 (1.76)	50 (1.969)	106.9 (4.209)	97.9 (3.854)	120 (4.724)	2.80 (6.17)	
2SP A16	16.5 (1.01)	230 (3335)	240 (3480)	250 (3625)	3500	57.7 (15.24)	500	7.83 (2.07)	52.1 (2.051)	111.1 (4.374)	102.1 (4.020)	120 (4.724)	2.95 (6.51)	
2SP A19	19.5 (1.19)	210 (3045)	220 (3190)	230 (3335)	3300	64.3 (16.99)	500	9.26 (2.45)	54.6 (2.150)	116.1 (4.571)	107.1 (4.217)	125 (4.921)	3.10 (6.84)	
2SP A22	22.5 (1.37)	190 (2755)	200 (2900)	210 (3045)	2800	63 (16.64)	500	10.68 (2.82)	57.1 (2.248)	121.1 (4.768)	112.1 (4.413)	130 (5.118)	3.25 (7.17)	
2SP A26	26 (1.59)	170 (2465)	180 (2610)	190 (2755)	2500	65 (17.17)	500	12.35 (3.26)	60 (2.362)	126.9 (4.996)	117.9 (4.642)	140 (5.512)	3.40 (7.50)	

* (Valori rilevati in fase di collaudo a 1500 giri/min / Value collected during the testing at 1500 rpm)

Esempio di ordinazione in codice / Example of ordering code

2SP | A | 14 | D | E53CX | (H) | - | 10 | G | (VT)

2SP	Tipo pompa / Pump type	vedi tabella / see table
A	Flangia e coperchio / Flange and cover	A = Alluminio / Aluminium
14	Cilindrata / Displacement	vedi tabella / see table
D	Rotazione destra / Clockwise rotation	D = Rotazione destra / Clockwise rotation S = Rotazione sinistra / Anticlockwise rotation
E52CX	Tipo flangia / Flange type	E52CX - E52CY
(H)	Anello di rinforzo per piccola pressione in aspirazione Stiffening seal for low suction pressure	(a richiesta / (optional))
-		
10	Tipo albero / Shaft type	17
G	Tipo connessioni / Connections type	G - N - T - M - U - W - F
(VT)	Opzioni / Optional	(VT) Guarnizione in Viton (a richiesta) Viton seals (optional) VLP-I (N) - VLP-E (N) Valvola limitatrice di pressione (pag. A-49) Pressure relief valve (page A-49)

Conn Connessioni / Connections

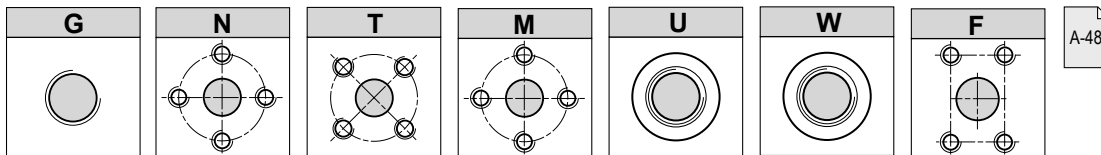

Versione
Version
E52CX

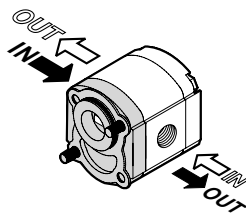

Versione
Version
E52CY

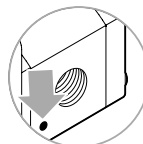
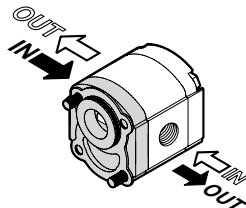

Il segno sul corpo indica il lato aspirazione per le pompe.
The sign on the body identify the suction side for the pumps.

Rotazione / Rotation	
D	S

E52C

POMPE GRUPPO
PUMPS GROUP

2

Dimensioni / Dimensions

Versione
Version
E52CX

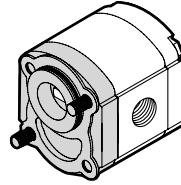

Versione
Version
E52CY

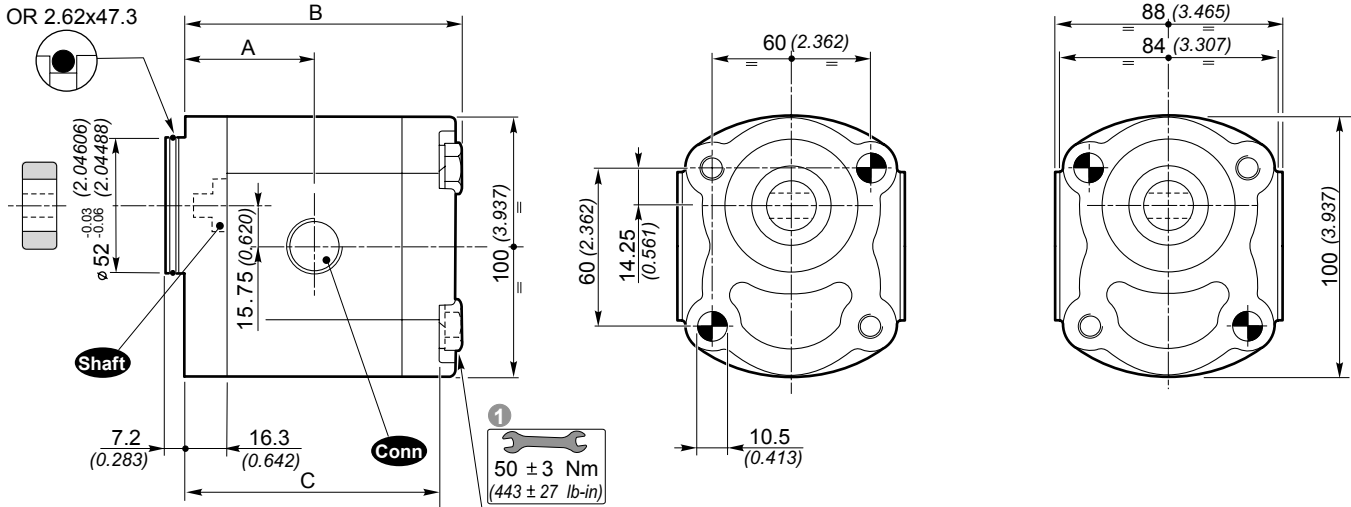
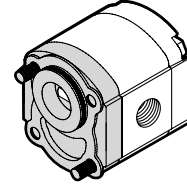

Shaft Alberi disponibili / Available shafts

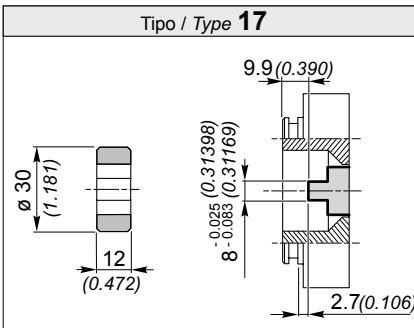

① Coppia di serraggio viti: $50 \pm 3 \text{ Nm}$. Utilizzare viti classe 10.9 - 12.9 UNI EN 20898/1.

Il fissaggio della pompa può essere effettuato con 2 viti prigioniere in materiale classe 10.9 - 12.9 preserrate a $40 \pm 3 \text{ Nm}$.
Fissare la pompa mediante dadi autobloccanti con coppia di serraggio $50 \pm 3 \text{ Nm}$.

Il Kit di viti per il fissaggio della pompa è da ordinare separatamente.
Codice di ordinazione del Kit di fissaggio:

① Tightening torque of screws: $443 \pm 27 \text{ lb-in}$. Use screws type 10.9 - 12.9 UNI EN 20898/1.

The assembling of the pump should be effected with 2 screw studs type 10.9 - 12.9 pre-tighten at $354 \pm 27 \text{ lb-in}$.
Fix the pump by self-locking nuts with tightening torque $443 \pm 27 \text{ lb-in}$.

The screws kit for the pump assembling should be ordered separately.
Ordering code of fixing Kit:

0029W + Lunghezza L (vedi tabella)
+ Lenght L (see table)

**POMPE GRUPPO
PUMPS GROUP**

2

PRKS 400 D

Dati tecnici / Technical data

Grandezza Size	Cilindrata Displacement [cm ³ /rev] (in ³ /rev)	Pressione max. d'esercizio Max. working pressure			Velocità max. Max. speed [g/min] (rpm)	Portata max. Max. flow [l/min] (Gal/min)	Velocità min. Min. speed [g/min] (rpm)	Portata min. Min. flow [l/min] (Gal/min)	Dimensioni Dimensions		Massa Mass [Kg] (lbs)	Rendimento volumetrico min. Min. volumetric efficiency %
		P1 [bar] (PSI)	P2 [bar] (PSI)	P3 [bar] (PSI)					A [mm] (inch)	B [mm] (inch)		
2SP A4	4 (0.24)	250 (3625)	270 (3915)	290 (4205)	4000	16 (4.23)	500	1.9 (0.50)	44.4 (1.748)	93 (3.661)	2.30 (5.07)	95*
2SP A6	6 (0.37)	250 (3625)	270 (3915)	290 (4205)	4000	24 (6.34)	500	2.85 (0.75)	46 (1.811)	96.3 (3.791)	2.45 (5.40)	
2SP A8	8.5 (0.52)	250 (3625)	270 (3915)	290 (4205)	3500	29.7 (7.85)	500	4.03 (1.06)	48.1 (1.894)	100.5 (3.957)	2.60 (5.73)	
2SP A11	11 (0.67)	250 (3625)	270 (3915)	290 (4205)	3500	38.5 (10.17)	500	5.22 (1.38)	50.2 (1.976)	104.6 (4.118)	2.70 (5.95)	
2SP A14	14 (0.85)	250 (3625)	270 (3915)	290 (4205)	3500	49 (12.95)	500	6.65 (1.76)	52.7 (2.075)	109.6 (4.315)	2.80 (6.17)	
2SP A16	16.5 (1.01)	230 (3335)	240 (3480)	250 (3625)	3500	57.7 (15.24)	500	7.83 (2.07)	54.8 (2.157)	113.8 (4.480)	2.95 (6.51)	
2SP A19	19.5 (1.19)	210 (3045)	220 (3190)	230 (3335)	3300	64.3 (16.99)	500	9.26 (2.45)	57.3 (2.256)	118.8 (4.677)	3.10 (6.84)	
2SP A22	22.5 (1.37)	190 (2755)	200 (2900)	210 (3045)	2800	63 (16.64)	500	10.68 (2.82)	59.8 (2.354)	123.8 (4.874)	3.25 (7.17)	
2SP A26	26 (1.59)	170 (2465)	180 (2610)	190 (2755)	2500	65 (17.17)	500	12.35 (3.26)	62.7 (2.469)	129.6 (5.102)	3.40 (7.50)	

* (Valori rilevati in fase di collaudo a 1500 giri/min / Value collected during the testing at 1500 rpm)

Esempio di ordinazione in codice / Example of ordering code

2SP | A | 14 | D | PRKS 400 D | - | G

2SP	Tipo pompa / Pump type	vedi tabella / see table
A	Flangia e coperchio / Flange and cover	A = Alluminio / Aluminium
14	Cilindrata / Displacement	vedi tabella / see table
D	Rotazione destra / Clockwise rotation	D = Rotazione destra (fornitura normale) Clockwise rotation (usually supplied) S = Rotazione sinistra / Anticlockwise rotation
PRKS0400 D	Flangia Perkins/ Perkins flange	PRKS 400 D
-		
G	Tipo connessioni / Connections type	G - N - T - M - U - W - F

Conn Connessioni / Connections

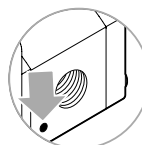
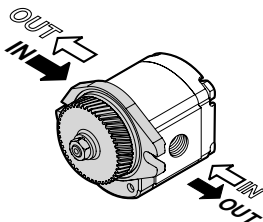
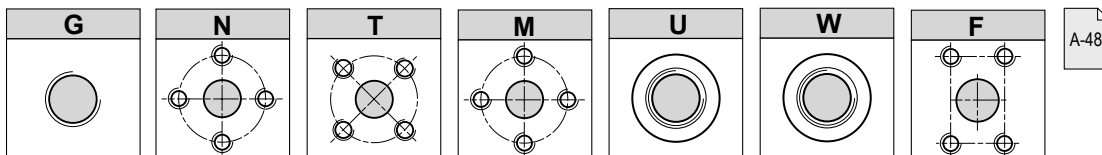

Il segno sul corpo indica il **lato aspirazione** per le pompe.
The sign on the body identify the **suction side** for the pumps.

Rotazione / Rotation	
D	S

PRKS 400 D POMPE GRUPPO PUMPS GROUP **2**

Dimensioni / Dimensions

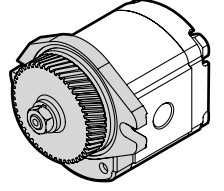
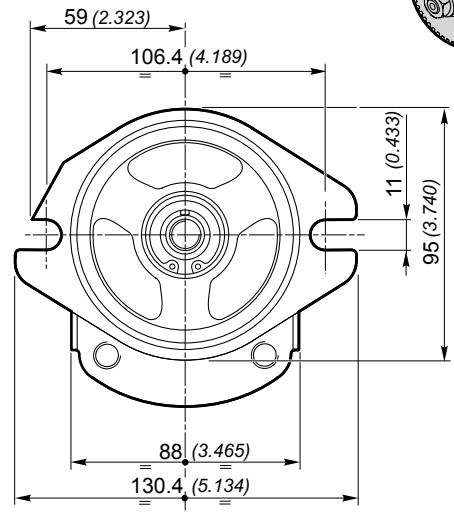
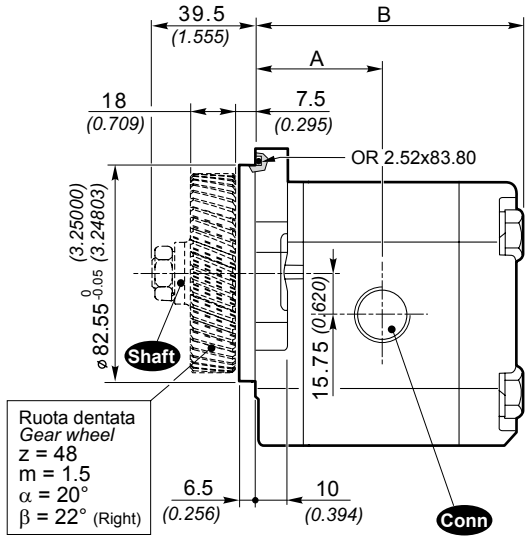

Shaft Alberi disponibili / Available shafts

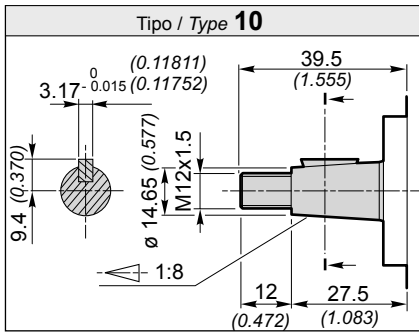

**POMPE GRUPPO
PUMPS GROUP**

2

SAE A 14*(z = 10), SAE A 14(z=11)**

Dati tecnici / Technical data

SAE A 14* z = 10

Grandezza Size	Cilindrata Displacement [cm³/rev] (in³/rev)	Pressione max. d'esercizio Max. working pressure			Velocità max. Max. speed [g/min] (rpm)	Portata max. Max. flow [lt/min] (Gal/min)	Velocità min. Min. speed [g/min] (rpm)	Portata min. Min. flow [lt/min] (Gal/min)	Dimensioni Dimensions		Massa Mass [Kg] (lbs)	Rendimento volumetrico min. Min. volumetric efficiency %
		P1 [bar] (PSI)	P2 [bar] (PSI)	P3 [bar] (PSI)					A [mm] (inch)	B [mm] (inch)		
2SP ...8	8.5 (0.52)	250 (3625)	270 (3915)	290 (4205)	3500	29.7 (7.85)	500	4.03 (1.06)	48.1 (1.894)	100.5 (3.957)	2.65 (5.84)	95*
2SP ...11	11 (0.67)	250 (3625)	270 (3915)	290 (4205)	3500	38.5 (10.17)	500	5.22 (1.38)	50.2 (1.976)	104.6 (4.118)	2.75 (6.06)	
2SP ...26	26 (1.59)	170 (2465)	180 (2610)	190 (2755)	2500	65 (17.17)	500	12.35 (3.26)	62.7 (2.469)	129.6 (5.102)	3.45 (7.61)	

SAE A 14 z = 11**

Grandezza Size	Cilindrata Displacement [cm³/rev] (in³/rev)	Pressione max. d'esercizio Max. working pressure			Velocità max. Max. speed [rpm]	Portata max. Max. flow [lt/min] (Gal/min)	Velocità min. Min. speed [rpm]	Portata min. Min. flow [lt/min] (Gal/min)	Dimensioni Dimensions		Massa Mass [Kg] (lbs)	Rendimento volumetrico min. Min. volumetric efficiency %
		P1 [bar] (PSI)	P2 [bar] (PSI)	P3 [bar] (PSI)					A [mm]	B [mm]		
2SP ...6	6 (0.37)	250 (3625)	270 (3915)	290 (4205)	4000	24 (6.34)	500	2.85 (0.75)	46 (1.811)	96.3 (3.791)	2.45 (5.40)	95*
2SP ...11	11 (0.67)	250 (3625)	270 (3915)	290 (4205)	3500	38.5 (10.17)	500	5.22 (1.38)	50.2 (1.976)	104.6 (4.118)	2.70 (5.95)	
2SP ...14	14 (0.85)	250 (3625)	270 (3915)	290 (4205)	3500	49 (12.95)	500	6.65 (1.76)	52.7 (2.075)	109.6 (4.315)	2.80 (6.17)	

* (Valori rilevati in fase di collaudo a 1500 giri/min / Value collected during the testing at 1500 rpm)

Esempio di ordinazione in codice / Example of ordering code

2SP | A | 26 | D | SAEA | - | 14* | G

2SP	Tipo pompa / Pump type	vedi tabella / see table
A	Flangia e coperchio / Flange and cover	A = Alluminio / Aluminium G = flangia e coperchio in ghisa Cast-iron flange and cover
26	Cilindrata / Displacement	vedi tabella / see table
D	Rotazione destra / Clockwise rotation	D = Rotazione destra / Clockwise rotation S = Rotazione sinistra / Anticlockwise rotation
SAEA	Tipo flangia / Flange type	SAE A
-		
14*	Tipo albero / Shaft type	14* - 14**
G	Tipo connessioni / Connections type	G - N - T - M - U - W - F

Conn Connessioni / Connections

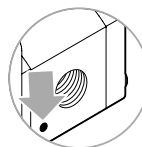
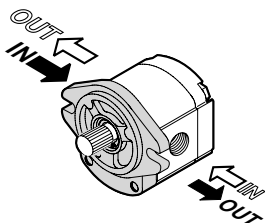
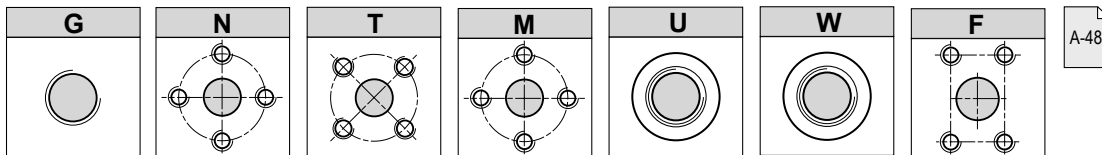

Il segno sul corpo indica il lato aspirazione per le pompe.
The sign on the body identify the suction side for the pumps.

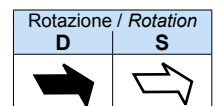

SAE A 14*(z = 10), SAE A 14 (z=11)**

**POMPE GRUPPO
PUMPS GROUP**

2

Dimensioni / Dimensions

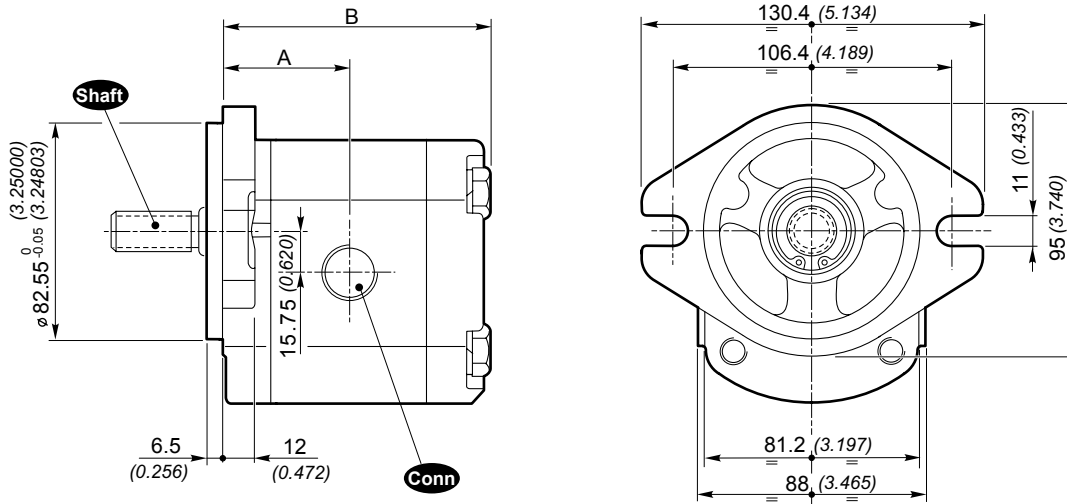
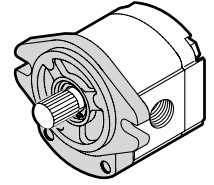

Shaft Alberi disponibili / Available shafts

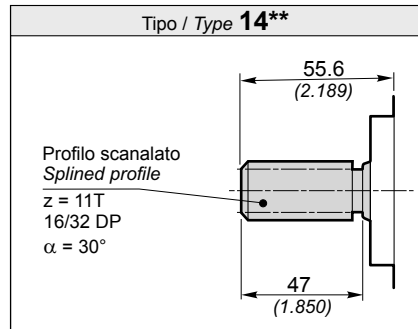
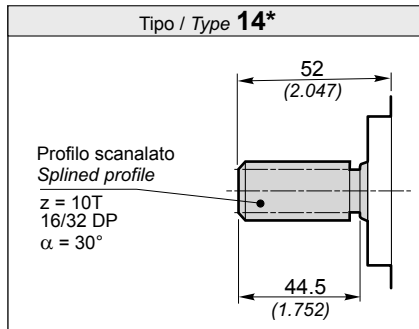

**POMPE GRUPPO
PUMPS GROUP**

GR 2

SUPP.STND

Versione da utilizzare in presenza di carichi assiali e/o radiali
Version to use with axial and/or radial loads

Dati tecnici / Technical data

Grandezza Size	Cilindrata Displacement [cm ³ /rev] (in ³ /rev)	Pressione max. d'esercizio Max. working pressure			Velocità max. Max. speed [g/min] (rpm)	Portata max. Max. flow [l/min] (Gal/min)	Velocità min. Min. speed [g/min] (rpm)	Portata min. Min. flow [l/min] (Gal/min)	Dimensioni Dimensions		Massa Mass [Kg] (lbs)	Rendimento volumetrico min. Min. volumetric efficiency %
		P1 [bar] (PSI)	P2 [bar] (PSI)	P3 [bar] (PSI)					A [mm] (inch)	B [mm] (inch)		
2SP A4	4 (0.24)	250 (3625)	270 (3915)	290 (4205)	4000	16 (4.23)	500	1.9 (0.50)	61.4 (2.417)	110 (4.331)	2.8 (6.17)	95*
2SP A6	6 (0.37)	250 (3625)	270 (3915)	290 (4205)	4000	24 (6.34)	500	2.85 (0.75)	63 (2.480)	113.3 (4.461)	2.95 (6.50)	
2SP A8	8.5 (0.52)	250 (3625)	270 (3915)	290 (4205)	3500	29.7 (7.85)	500	4.03 (1.06)	65.1 (2.563)	117.5 (4.626)	3.1 (6.84)	
2SP A11	11 (0.67)	250 (3625)	270 (3915)	290 (4205)	3500	38.5 (10.17)	500	5.22 (1.38)	67.2 (2.646)	121.6 (4.787)	3.2 (7.06)	
2SP A14	14 (0.85)	250 (3625)	270 (3915)	290 (4205)	3500	49 (12.95)	500	6.65 (1.76)	69.7 (2.744)	126.6 (4.984)	3.3 (7.28)	
2SP A16	16.5 (1.01)	230 (3335)	240 (3480)	250 (3625)	3500	57.7 (15.24)	500	7.83 (2.07)	71.8 (2.827)	130.8 (5.150)	3.45 (7.61)	
2SP A19	19.5 (1.19)	210 (3045)	220 (3190)	230 (3335)	3300	64.3 (16.99)	500	9.26 (2.45)	74.3 (2.925)	135.8 (5.346)	3.6 (7.94)	
2SP A22	22.5 (1.37)	190 (2755)	200 (2900)	210 (3045)	2800	63 (16.64)	500	10.68 (2.82)	76.8 (3.024)	140.8 (5.543)	3.75 (8.27)	
2SP A26	26 (1.59)	170 (2465)	180 (2610)	190 (2755)	2500	65 (17.17)	500	12.35 (3.26)	79.7 (3.138)	148.8 (5.858)	3.9 (8.60)	

* (Valori rilevati in fase di collaudo a 1500 giri/min / Value collected during the testing at 1500 rpm)

Esempio di ordinazione in codice / Example of ordering code

2SP	A	14	D	SUPP.STND	-	10	G	(VT)
------------	----------	-----------	----------	------------------	----------	-----------	----------	-------------

2SP	Tipo pompa / Pump type	vedi tabella / see table
A	Flangia e coperchio / Flange and cover	A = Alluminio / Aluminium
14	Cilindrata / Displacement	vedi tabella / see table
D	Rotazione destra / Clockwise rotation	D = Rotazione destra / Clockwise rotation S = Rotazione sinistra / Anticlockwise rotation
SUPP.STND	Tipo supporto / Support type	SUPP.STND
-		
10	Tipo albero / Shaft type	10
G	Tipo connessioni / Connections type	G - N - T - M - U - W - F
(VT)	Opzioni / Optional	(VT) Guarnizione in Viton (a richiesta) Viton seals (optional) VLP-I (N) - VLP-E (N) Valvola limitatrice di pressione (pag. A-49) Pressure relief valve (page A-49)

Non è necessario indicare la flangia STANDARD

It is not necessary indicate STANDARD flange

Conn Connessioni / Connections

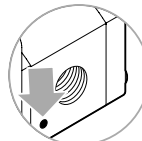
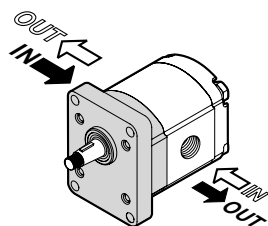
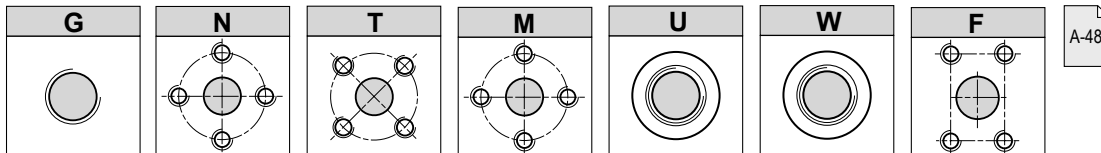

Il segno sul corpo indica il lato aspirazione per le pompe.
The sign on the body identify the suction side for the pumps.

Rotazione / Rotation	
D	S

Versione da utilizzare in presenza di carichi assiali e/o radiali
Version to be chosen with axial and/or radial loads

SUPP.STND

POMPE GRUPPO
PUMPS GROUP

GR 2

Dimensioni / Dimensions

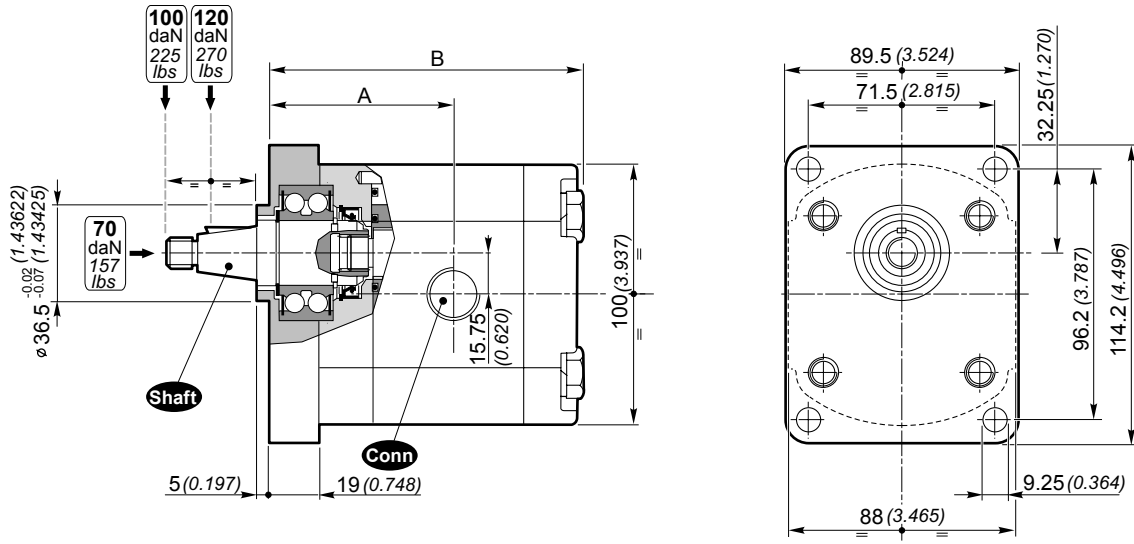
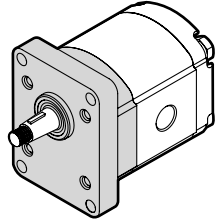

Shaft Alberi disponibili / Available shafts

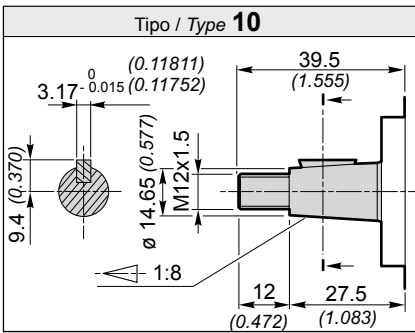

POMPE GRUPPO
PUMPS GROUP

2

CONNESSIONI / CONNECTIONS

G

Aspirazione
Suction

Mandata
Delivery

Grand./ Size	4 ÷ 8	
C	G 1/2"	

Grand./ Size	11 ÷ 26	
C	G 3/4"	

N

Aspirazione
Suction

Mandata
Delivery

Grand./ Size	4 ÷ 8		
C	D	d	
13 (0.512)	30 (1.181)	M6	

Grand./ Size	11 ÷ 26		
C	D	d	
19 (0.748)	40 (1.575)	M8	

T

Aspirazione
Suction

Mandata
Delivery

M

Aspirazione
Suction

Mandata
Delivery

Grand./ Size	11 ÷ 26	
C	D	
19 (0.748)	40 (1.575)	

U

Aspirazione
Suction

Mandata
Delivery

Grand./ Size	4 ÷ 8	
C	7/8 14UNF	

Grand./ Size	11 ÷ 26	
C	1" 1/16 12UN	

W

Aspirazione
Suction

Mandata
Delivery

F

Aspirazione
Suction

Mandata
Delivery

Grand./ Size	4 ÷ 11		
C	D	E	
20 (0.787)	38 (1.496)	17.4 (0.685)	

Grand./ Size	14 ÷ 26		
C	D	E	
26 (1.024)	22.4 (0.882)	47.6 (1.874)	

Il segno sul corpo indica il lato aspirazione per le pompe.
The sign on the body identify the suction side for the pumps.

Posizione delle connessioni / Connections positions

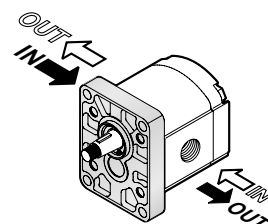

Rotazione / Rotation	
D	S

OPZIONI / OPTIONAL

POMPE GRUPPO
PUMPS GROUP

2

VLP- I (N)

Valvola limitatrice di pressione a scarico interno
Pressure relief valve with internal exhaust

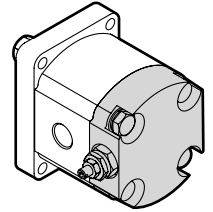
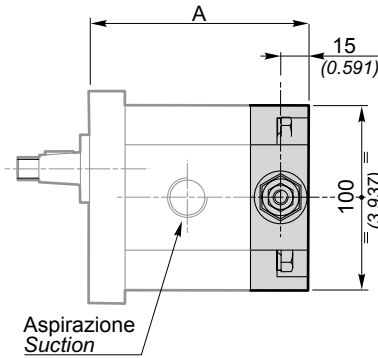
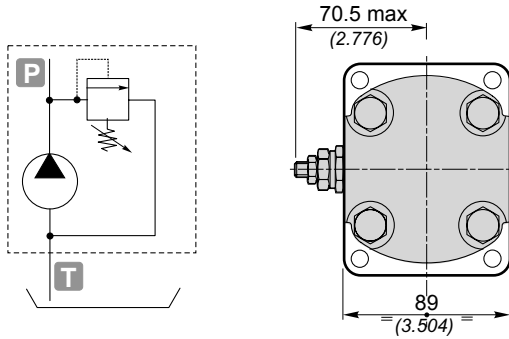

	A		
	Standard SAE A B50C	B80C	E52C
2SP A4	44.4 (1.748)	46.4 (1.827)	41.7 (1.642)
2SP A6	46 (1.811)	48.0 (1.890)	43.3 (1.705)
2SP A8	48.1 (1.894)	50.1 (1.972)	45.4 (1.787)
2SP A11	50.2 (1.976)	52.2 (2.055)	47.5 (1.870)
2SP A14	52.7 (2.075)	54.7 (2.154)	50.0 (1.969)
2SP A16	54.8 (2.157)	56.8 (2.236)	52.1 (2.051)
2SP A19	57.3 (2.256)	59.3 (2.335)	54.6 (2.150)
2SP A22	59.8 (2.354)	61.8 (2.433)	57.1 (2.248)
2SP A26	62.7 (2.469)	64.7 (2.547)	60.0 (2.362)

VLP- E (N)

Valvola limitatrice di pressione a scarico esterno
Pressure relief valve with external exhaust

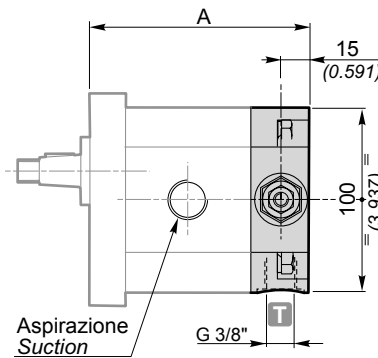
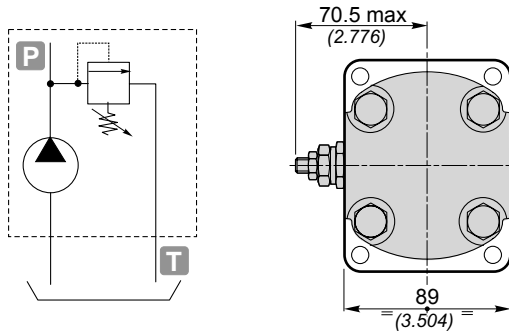

NB.
La valvola limitatrice di pressione si applica sostituendo il coperchio posteriore.
Fornitura solo con flangia e coperchio in Alluminio.
Sono rappresentate pompe con rotazione sinistra.

Warning.
The pressure relief valve can be applied by substituting the rear cover.
It is supplied only with aluminium flange and cover.
The showed pumps are anticlockwise rotation.

L'apertura della valvola limitatrice di pressione deve avvenire per tempi non superiori ai 10 secondi ogni minuto per evitare il surriscaldamento della pompa.

The opening of the pressure relief valve should be carry out for times not over 10" each minute to avoid the overheating of the pump.

Esempio di ordinazione in codice / Example of ordering code

2SP	A	14	D	SAE A	-	10	G	(VT)	VLP-I	(N)
VLP-I	Coperchio con VLP Cover with VLP					VPL-I (a scarico interno /at internal exhaust) VLP-E (a scarico esterno /at external exhaust)				
(N)	Tipo di molla / Spring type					B - N - R (vedi tabella / See table)				

		Tipo di molla / Spring type		
		B	N	R
		molla bianca white spring	molla nera black spring	molla rossa red spring
Campi di taratura* Calibration fields*	[bar] (psi)	10 ÷ 100 (145 ÷ 1450)	30 ÷ 280 (435 ÷ 4060)	80 ÷ 380 (1160 ÷ 5510)

* In caso di omissione del valore di taratura, esso sarà inteso standard (molla nera con taratura 150 bar).

* Without setting request, it will be considered standard (black spring: 2175 psi).

VRF

Valvola regolatrice di flusso
Priority flow divider valve

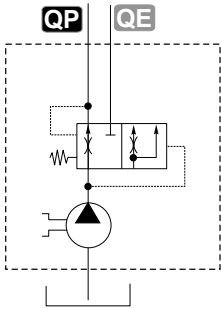
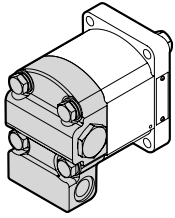

Flusso eccedente per
utilizzi o serbatoio
Exceeding flow to
actuator or to tank

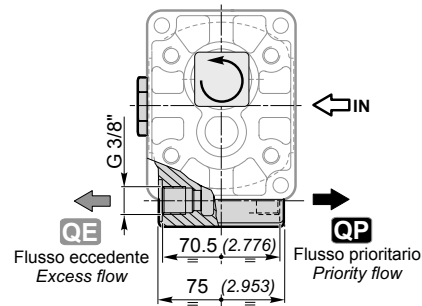
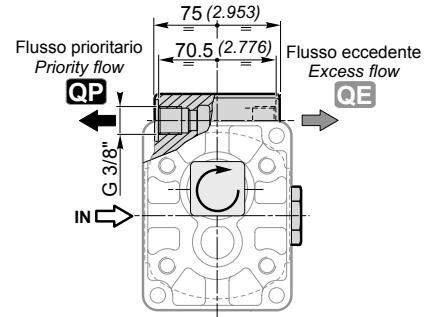
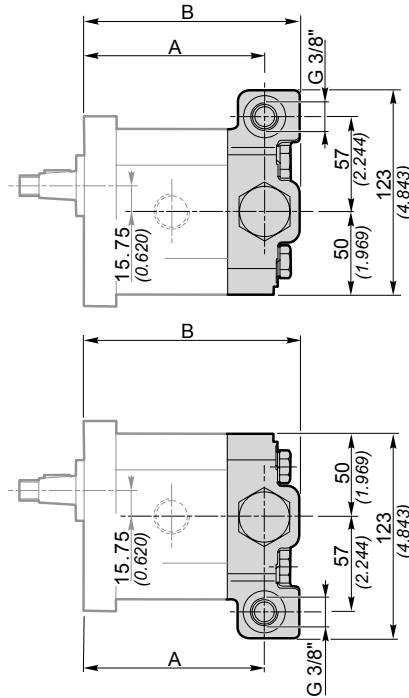

		2SP...4	2SP...6	2SP...8	2SP...11	2SP...14	2SP...16	2SP...19	2SP...22	2SP...26
A	Standard	91.8 (3.614)	95.1 (3.744)	99.3 (3.909)	103.4 (4.071)	108.4 (4.268)	112.6 (4.433)	117.6 (4.630)	122.6 (4.827)	128.4 (5.055)
	SAE AA	93.8 (3.693)	97.1 (3.823)	101.3 (3.988)	105.4 (4.150)	110.4 (4.346)	114.6 (4.512)	119.6 (4.709)	124.6 (4.906)	130.4 (5.134)
	E32 BX	89.1 (3.508)	92.4 (3.638)	92.4 (3.638)	100.7 (3.965)	105.7 (4.161)	109.9 (4.327)	114.9 (4.524)	119.9 (4.720)	125.7 (4.949)
	E32 CX									
B	Standard	112.8 (4.441)	116.1 (4.571)	120.3 (4.736)	124.4 (4.898)	129.4 (5.094)	133.6 (5.260)	138.6 (5.457)	143.6 (5.654)	149.4 (5.882)
	SAE AA	114.8 (4.520)	118.1 (4.650)	122.3 (4.815)	126.4 (4.976)	131.4 (5.173)	135.6 (5.339)	140.6 (5.535)	145.6 (5.732)	151.4 (5.961)
	E32 BX	110.1 (4.335)	113.4 (4.465)	117.6 (4.630)	121.7 (4.791)	126.7 (4.988)	130.9 (5.154)	135.9 (5.350)	140.9 (5.547)	146.7 (5.776)
	E32 CX									

Esempio di ordinazione in codice / Example of ordering code

2SP	A	14	D	SAE A	-	10	G	(VT)	VRF	(d)	
VRF	Coperchio con VRF Cover with VRF						VRF				
(d)	Diametro del foro calibrato Diameter of calibrated orifice						2.5 - 3 - 3.25 - 4 - 4.25 - 5.5 (Vedi tabella / See table)				

d [mm]	Q [l/min] (US.gal/min)
2.5	5 (1.32)
3	7 (1.32)
3.25	8 (1.32)
4	11 (1.32)
4.25	14 (1.32)
5.5	21 (1.32)

OPZIONI / OPTIONAL

POMPE GRUPPO
PUMPS GROUP

2

VRF - VLP-I

Valvola regolatrice di flusso e valvola li mitatrice di pressione
Priority flow divider valve and pressure relief valve

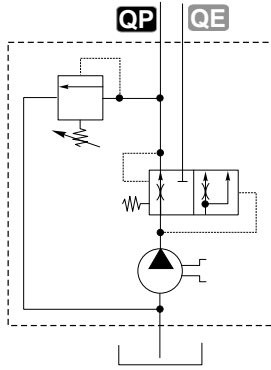
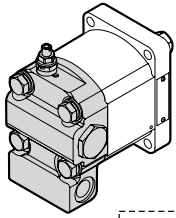

Flusso eccedente per utilizzi o serbatoio
Exceeding flow to actuator or to tank

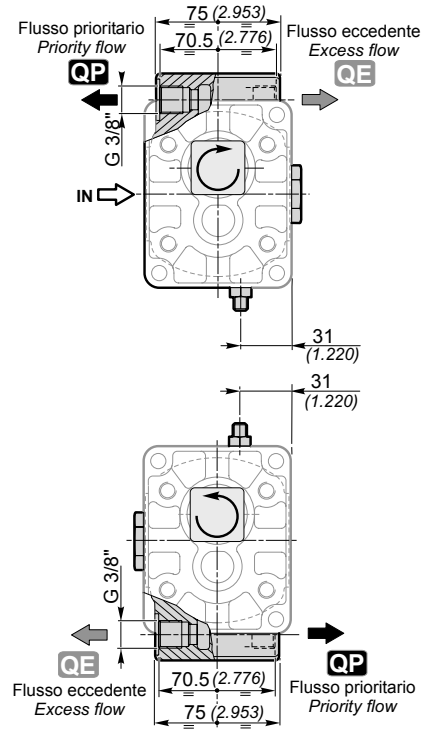
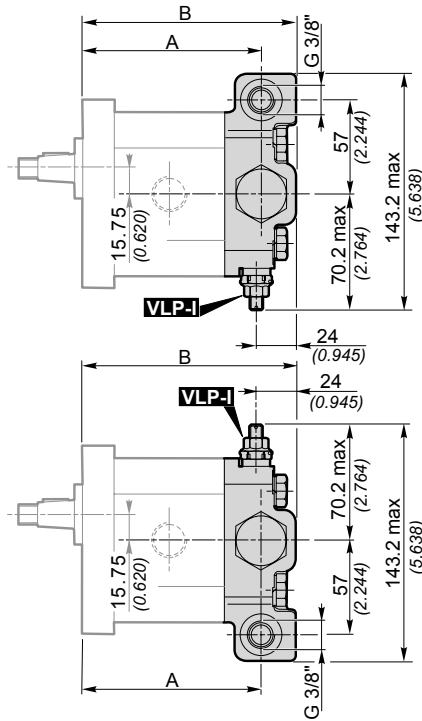

		2SP...4	2SP...6	2SP...8	2SP...11	2SP...14	2SP...16	2SP...19	2SP...22	2SP...26
A	Standard	91.8 (3.614)	95.1 (3.744)	99.3 (3.909)	103.4 (4.071)	108.4 (4.268)	112.6 (4.433)	117.6 (4.630)	122.6 (4.827)	128.4 (5.055)
	SAE AA	93.8 (3.693)	97.1 (3.823)	101.3 (3.988)	105.4 (4.150)	110.4 (4.346)	114.6 (4.512)	119.6 (4.709)	124.6 (4.906)	130.4 (5.134)
	E32 BX E32 CX	89.1 (3.508)	92.4 (3.638)	92.4 (3.638)	100.7 (3.965)	105.7 (4.161)	109.9 (4.327)	114.9 (4.524)	119.9 (4.720)	125.7 (4.949)
B	Standard	112.8 (4.441)	116.1 (4.571)	120.3 (4.736)	124.4 (4.898)	129.4 (5.094)	133.6 (5.260)	138.6 (5.457)	143.6 (5.654)	149.4 (5.882)
	SAE AA	114.8 (4.520)	118.1 (4.650)	122.3 (4.815)	126.4 (4.976)	131.4 (5.173)	135.6 (5.339)	140.6 (5.535)	145.6 (5.732)	151.4 (5.961)
	E32 BX E32 CX	110.1 (4.335)	113.4 (4.465)	117.6 (4.630)	121.7 (4.791)	126.7 (4.988)	130.9 (5.154)	135.9 (5.350)	140.9 (5.547)	146.7 (5.776)

Esempio di ordinazione in codice / Example of ordering code

2SP	A	14	D	SAE A	-	10	G	(VT)	VRF	(d)	-	VLP-I	(N)
VRF	Coperchio con VRF Cover with VRF								VRF				
(d)	Diametro del foro calibrato Diameter of calibrated orifice								2.5 - 3 - 3.25 - 4 - 4.25 - 5.5 (Vedi tabella / See table)				
VLP-I	Coperchio con VLP Cover with VLP								VLP-I (a scarico interno / at internal exhaust)				
(N)	Tipo di molla / Spring type								B - N - R (vedi tabella / See table)				

		Tipo di molla / Spring type		
		B	N	R
		molla bianca white spring	molla nera black spring	molla rossa red spring
Campi di taratura* Calibration fields*	[bar] (psi)	10 ÷ 100 (145 ÷ 1450)	30 ÷ 280 (435 ÷ 4060)	80 ÷ 380 (1160 ÷ 5510)
Il range completo si ottiene mediante l'aggiunta di spessori The complete range can be obtained with additional thickness				

d	Q
[mm]	[l/min] (US.gal/min)
2.5	5 (1.32)
3	7 (1.32)
3.25	8 (1.32)
4	11 (1.32)
4.25	14 (1.32)
5.5	21 (1.32)

* In caso di omissione del valore di taratura, esso sarà inteso standard (molla nera con taratura 150 bar).

* Without setting request, it will be considered standard (black spring: 2175 psi).

**POMPE GRUPPO
PUMPS GROUP**

3

Standard

**Flangia e coperchio in Alluminio
Flange and cover in Aluminium**

Dati tecnici / Technical data

Grandezza Size	Cilindrata Displacement [cm ³ /rev] (in ³ /rev)	Pressione max. d'esercizio Max. working pressure			Velocità max. Max. speed [g/min] (rpm)	Portata max. Max. flow [l/min] (Gal/min)	Velocità min. Min. speed [g/min] (rpm)	Portata min. Min. flow [l/min] (Gal/min)	Dimensioni Dimensions		Massa Mass [Kg] (lbs)	Rendimento volumetrico min. Min. volumetric efficiency %
		P1 [bar] (PSI)	P2 [bar] (PSI)	P3 [bar] (PSI)					A [mm] (inch)	B [mm] (inch)		
3SP A19	19 (1.16)	250 (3625)	270 (3915)	300 (4350)	3500	66.5 (17.57)	700	12.64 (3.34)	62.4 (2.457)	128.3 (5.051)	5.23 (11.53)	95*
3SP A22	22.3 (1.36)	240 (3480)	260 (3770)	290 (4205)	3500	78 (20.61)	700	14.83 (3.92)	63.9 (2.516)	131.3 (5.169)	5.36 (11.82)	
3SP A29	29.3 (1.79)	220 (3190)	240 (3480)	260 (3770)	3300	96.7 (25.55)	700	19.48 (5.15)	66.9 (2.634)	137.3 (5.406)	5.64 (12.44)	
3SP A33	32.9 (2.01)	220 (3190)	230 (3335)	260 (3770)	3300	108.6 (28.69)	700	21.88 (5.78)	68.4 (2.693)	140.3 (5.524)	5.78 (12.75)	
3SP A36	36.4 (2.22)	210 (3045)	230 (3335)	250 (3625)	3300	120.1 (31.73)	700	24.21 (6.40)	69.9 (2.752)	143.3 (5.642)	5.91 (13.03)	
3SP A44	43.5 (2.65)	200 (2900)	220 (3190)	240 (3480)	3000	130.5 (34.48)	700	28.93 (7.64)	72.9 (2.870)	149.3 (5.878)	6.19 (13.65)	
3SP A52	51.7 (3.15)	200 (2900)	210 (3045)	240 (3480)	3000	155.1 (40.98)	700	34.38 (9.08)	76.4 (3.008)	156.3 (6.154)	6.50 (14.33)	
3SP A62	61.1 (3.73)	180 (2610)	190 (2755)	200 (2900)	2500	152.7 (40.34)	700	40.63 (10.73)	80.4 (3.165)	164.3 (6.469)	6.87 (15.15)	

* (Valori rilevati in fase di collaudo a 1500 giri/min / Value collected during the testing at 1500 rpm)

Esempio di ordinazione in codice / Example of ordering code

3SP | A | 22 | D | (H) | - | 10 | G | (VT)

3SP	Tipo pompa / Pump type	vedi tabella / see table
A	Flangia e coperchio / Flange and cover	A = Alluminio / Aluminium
22	Cilindrata / Displacement	vedi tabella / see table
D	Rotazione destra / Clockwise rotation	D = Rotazione destra / Clockwise rotation S = Rotazione sinistra / Anticlockwise rotation
(H)	Anello di rinforzo per piccola pressione in aspirazione Stiffening seal for low suction pressure	(a richiesta / optional)
-		
10	Tipo albero / Shaft type	10 - 13 - 14
G	Tipo connessioni / Connections type	G - N - W - F - T
(VT)	Opzioni / Optional	(VT) Guarnizione in Viton (a richiesta) Viton seals (optional) VLP-I (N) Valvola limitatrice di pressione (pag. A-63) Pressure relief valve (page A-63)

Conn Connessioni / Connections

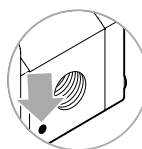
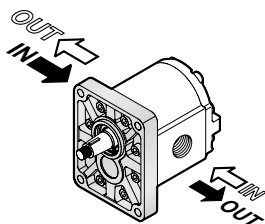
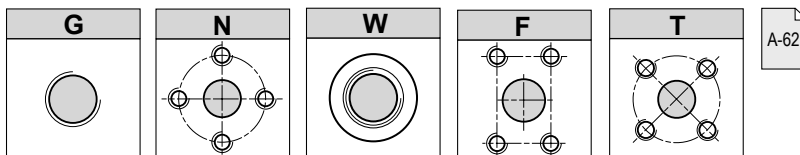

Il segno sul corpo indica il **lato aspirazione** per le pompe.
The sign on the body identify the **suction side** for the pumps.

Rotazione / Rotation	
D	S

Flangia e coperchio in Alluminio
Flange and cover in Aluminium

Standard

POMPE GRUPPO
PUMPS GROUP

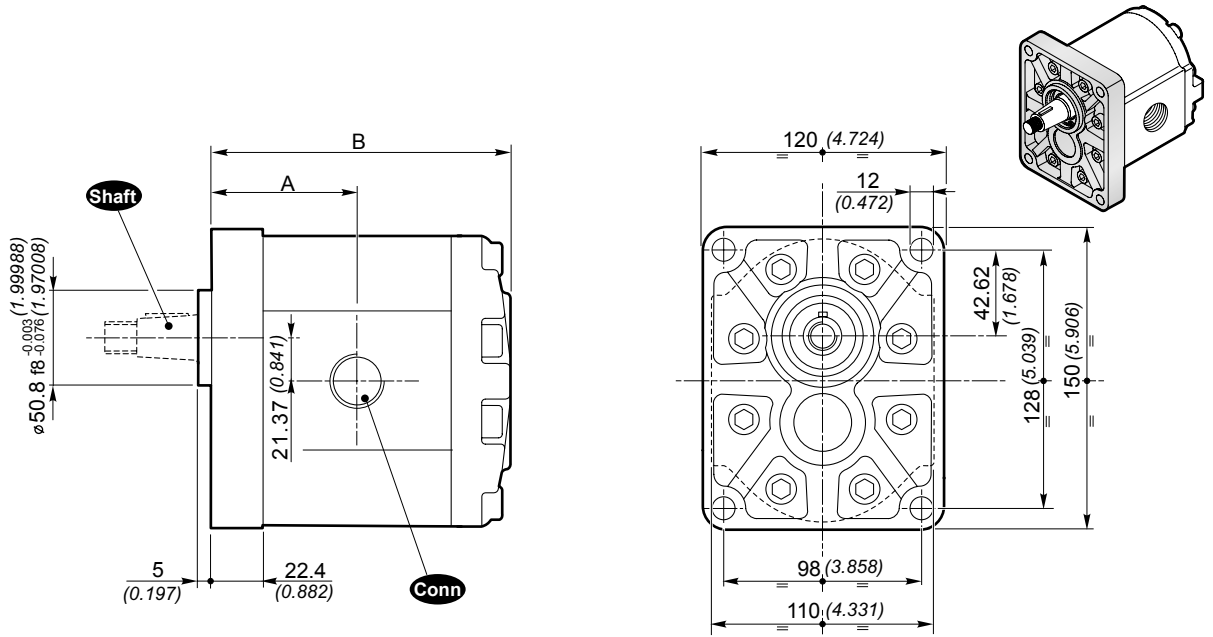

Shaft Alberi disponibili / Available shafts

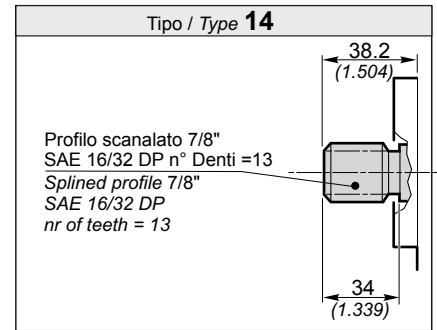
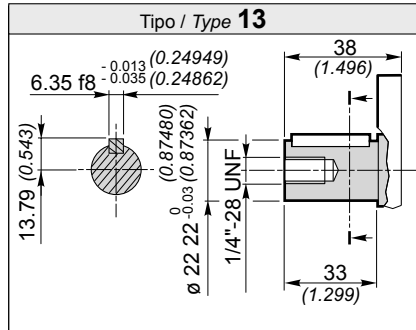
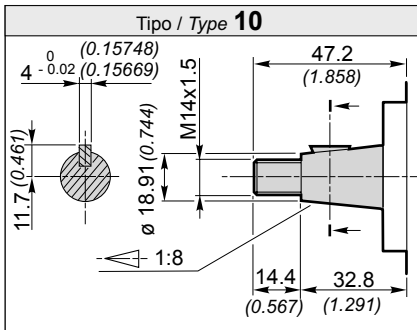

**POMPE GRUPPO
PUMPS GROUP**

3

Standard

**Flangia e coperchio in Ghisa
Flange and cover in Cast iron**

Dati tecnici / Technical data

Grandezza Size	Cilindrata Displacement [cm ³ /rev] (in ³ /rev)	Pressione max. d'esercizio Max. working pressure			Velocità max. Max. speed [g/min] (rpm)	Portata max. Max. flow [l/min] (Gal/min)	Velocità min. Min. speed [g/min] (rpm)	Portata min. Min. flow [l/min] (Gal/min)	Dimensioni Dimensions		Massa Mass [Kg] (lbs)	Rendimento volumetrico min. Min. volumetric efficiency %
		P1 [bar] (PSI)	P2 [bar] (PSI)	P3 [bar] (PSI)					A [mm] (inch)	B [mm] (inch)		
3SP G19	19 (1.16)	270 (3915)	290 (4205)	320 (4640)	3500	66.5 (17.57)	700	12.64 (3.34)	62.4 (2.457)	128.3 (5.051)	7.53 (16.60)	95*
3SP G22	22.3 (1.36)	260 (3770)	280 (4060)	300 (4350)	3500	78 (20.61)	700	14.83 (3.92)	63.9 (2.516)	131.3 (5.169)	7.66 (16.89)	
3SP G29	29.3 (1.79)	240 (3480)	260 (3770)	280 (4060)	3300	96.7 (25.55)	700	19.48 (5.15)	66.9 (2.634)	137.3 (5.406)	7.94 (17.51)	
3SP G33	32.9 (2.01)	240 (3480)	260 (3770)	280 (4060)	3300	108.6 (28.69)	700	21.88 (5.78)	68.4 (2.693)	140.3 (5.524)	8.08 (17.82)	
3SP G36	36.4 (2.22)	230 (3335)	250 (3625)	270 (3915)	3300	120.1 (31.73)	700	24.21 (6.40)	69.9 (2.752)	143.3 (5.642)	8.21 (18.10)	
3SP G44	43.5 (2.65)	200 (2900)	220 (3190)	240 (3480)	3000	130.5 (34.48)	700	28.93 (7.64)	72.9 (2.870)	149.3 (5.878)	8.49 (18.72)	
3SP G52	51.7 (3.15)	200 (2900)	220 (3190)	240 (3480)	3000	155.1 (40.98)	700	34.38 (9.08)	76.4 (3.008)	156.3 (6.154)	8.80 (19.40)	
3SP G62	61.1 (3.73)	180 (2610)	190 (2755)	200 (2900)	2500	152.7 (40.34)	700	40.63 (10.73)	80.4 (3.165)	164.3 (6.469)	9.17 (20.22)	

* (Valori rilevati in fase di collaudo a 1500 giri/min / Value collected during the testing at 1500 rpm)

Esempio di ordinazione in codice / Example of ordering code

3SP G 22 D (H) - 10 G (VT)

3SP	Tipo pompa / Pump type	vedi tabella / see table
G	Flangia e coperchio / Flange and cover	G = Ghisa / Cast iron
22	Cilindrata / Displacement	vedi tabella / see table
D	Rotazione destra / Clockwise rotation	D = Rotazione destra / Clockwise rotation S = Rotazione sinistra / Anticlockwise rotation
(H)	Anello di rinforzo per piccola pressione in aspirazione Stiffening seal for low suction pressure	(a richiesta / optional)
-		
10	Tipo albero / Shaft type	10 - 13 - 14
G	Tipo connessioni / Connections type	G - N - W - F - T
(VT)	Opzioni / Optional	(VT) Guarnizione in Viton (a richiesta) Viton seals (optional) VLP-I (N) Valvola limitatrice di pressione (pag. A-63) Pressure relief valve (page A-63)

Conn Connessioni / Connections

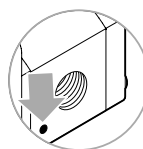
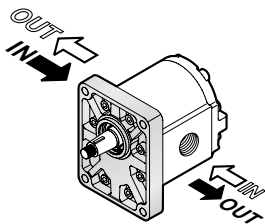
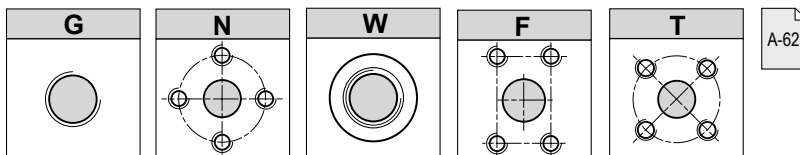

Il segno sul corpo indica il **lato aspirazione** per le pompe.
The sign on the body identify the **suction side** for the pumps.

Rotazione / Rotation	
D	S

Flangia e coperchio in Ghisa
Flange and cover in Cast iron

Standard

POMPE GRUPPO
PUMPS GROUP

3

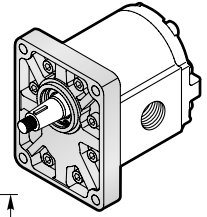
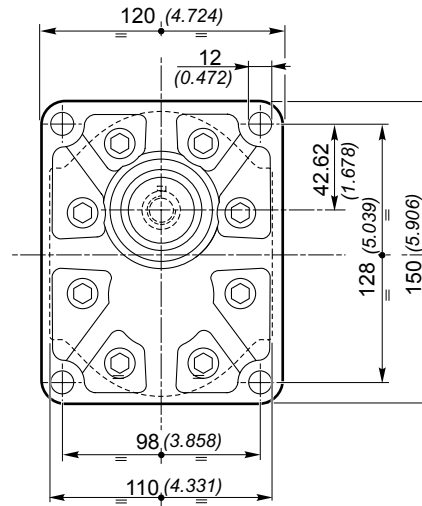
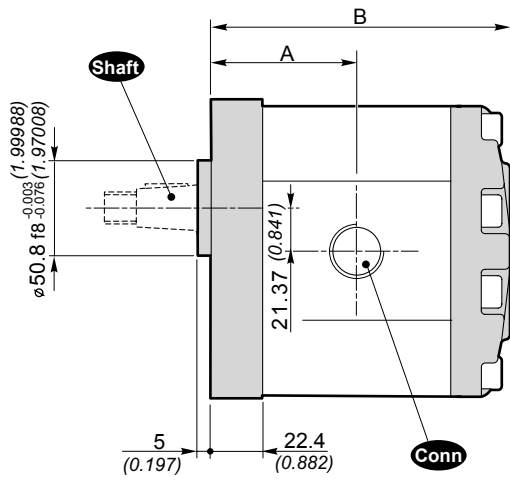

Shaft Alberi disponibili / Available shafts

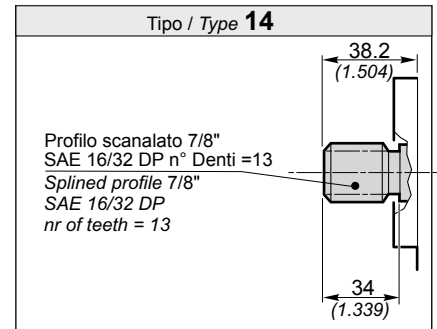
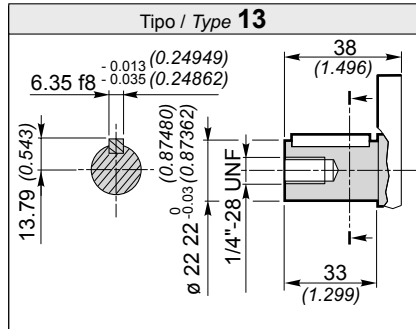
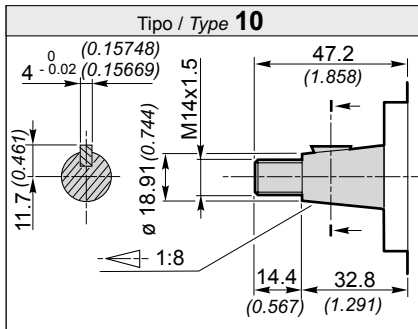

**POMPE GRUPPO
PUMPS GROUP**

3

SAE B, SAE B-OR

**Flangia e coperchio in Alluminio
Flange and cover in Aluminium**

Dati tecnici / Technical data

Grandezza Size	Cilindrata Displacement [cm ³ /rev] (in ³ /rev)	Pressione max. d'esercizio Max. working pressure			Velocità max. Max. speed [g/min] (rpm)	Portata max. Max. flow [l/min] (Gal/min)	Velocità min. Min. speed [g/min] (rpm)	Portata min. Min. flow [l/min] (Gal/min)	Dimensioni Dimensions		Massa Mass [Kg] (lbs)	Rendimento volumetrico min. Min. volumetric efficiency %
		P1 [bar] (PSI)	P2 [bar] (PSI)	P3 [bar] (PSI)					A [mm] (inch)	B [mm] (inch)		
3SP A19	19 (1.16)	250 (3625)	270 (3915)	300 (4350)	3500	66.5 (17.57)	700	12.64 (3.34)	59.4 (2.339)	125.3 (4.933)	5.23 (11.53)	95*
3SP A22	22.3 (1.36)	240 (3480)	260 (3770)	290 (4205)	3500	78 (20.61)	700	14.83 (3.92)	60.9 (2.398)	128.3 (5.051)	5.36 (11.82)	
3SP A29	29.3 (1.79)	220 (3190)	240 (3480)	260 (3770)	3300	96.7 (25.55)	700	19.48 (5.15)	63.9 (2.516)	134.3 (5.287)	5.64 (12.44)	
3SP A33	32.9 (2.01)	220 (3190)	230 (3335)	260 (3770)	3300	108.6 (28.69)	700	21.88 (5.78)	65.4 (2.575)	137.3 (5.406)	5.78 (12.75)	
3SP A36	36.4 (2.22)	210 (3045)	230 (3335)	250 (3625)	3300	120.1 (31.73)	700	24.21 (6.40)	66.9 (2.634)	140.3 (5.124)	5.91 (13.03)	
3SP A44	43.5 (2.65)	200 (2900)	220 (3190)	240 (3480)	3000	130.5 (34.48)	700	28.93 (7.64)	69.9 (2.752)	146.3 (5.760)	6.19 (13.65)	
3SP A52	51.7 (3.15)	200 (2900)	210 (3045)	240 (3480)	3000	155.1 (40.98)	700	34.38 (9.08)	73.4 (2.890)	153.3 (6.035)	6.50 (14.33)	
3SP A62	61.1 (3.73)	180 (2610)	190 (2755)	200 (2900)	2500	152.7 (40.34)	700	40.63 (10.73)	77.4 (3.047)	161.3 (6.350)	6.87 (15.15)	

* (Valori rilevati in fase di collaudo a 1500 giri/min / Value collected during the testing at 1500 rpm)

Esempio di ordinazione in codice / Example of ordering code

3SP | A | 22 | D | (H) | SAEB | - | 14 | G | (VT)

3SP	Tipo pompa / Pump type	vedi tabella / see table
A	Flangia e coperchio / Flange and cover	A = Alluminio / Aluminium
22	Cilindrata / Displacement	vedi tabella / see table
D	Rotazione destra / Clockwise rotation	D = Rotazione destra / Clockwise rotation S = Rotazione sinistra / Anticlockwise rotation
(H)	Anello di rinforzo per piccola pressione in aspirazione Stiffening seal for low suction pressure	(a richiesta / optional)
SAEB	Tipo flangia / Flange type	SAE B - SAE B - OR
-		
14	Tipo albero / Shaft type	10 - 13 - 14
G	Tipo connessioni / Connections type	G - N - W - F - T
(VT)	Opzioni / Optional	(VT) Guarnizione in Viton (a richiesta) Viton seals (optional) VLP-I (N) Valvola limitatrice di pressione (pag. A-63) Pressure relief valve (page A-63)

Conn Connessioni / Connections

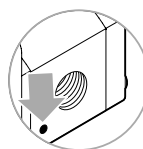
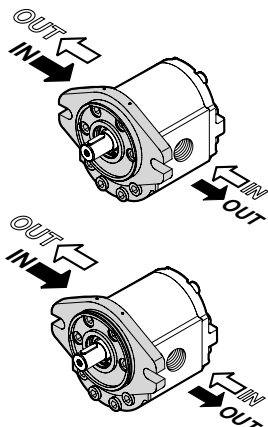
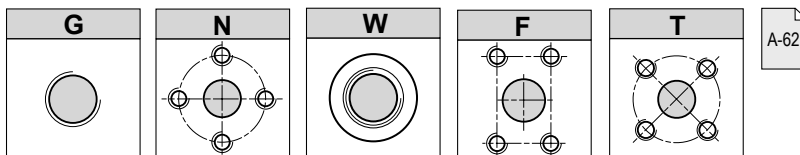

Il segno sul corpo indica il **lato aspirazione** per le pompe.
The sign on the body identify the **suction side** for the pumps.

Rotazione / Rotation	
D	S

Flangia e coperchio in Alluminio
Flange and cover in Aluminium

SAE B, SAE B-OR

POMPE GRUPPO
PUMPS GROUP

3

SAE B-OR

SAE B

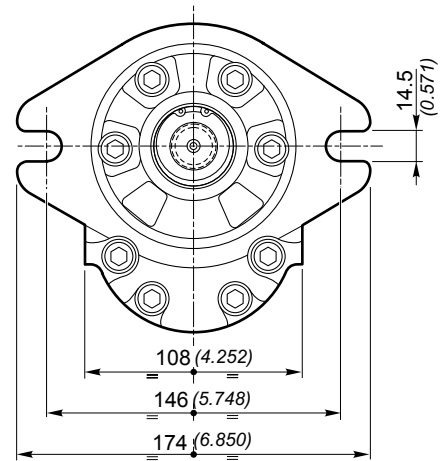
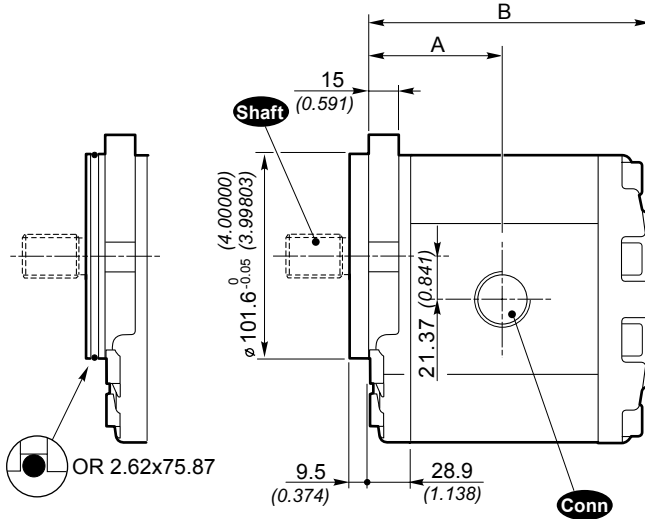
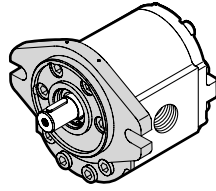
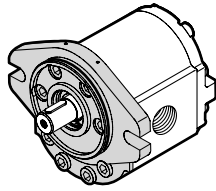

Shaft Alberi disponibili / Available shafts

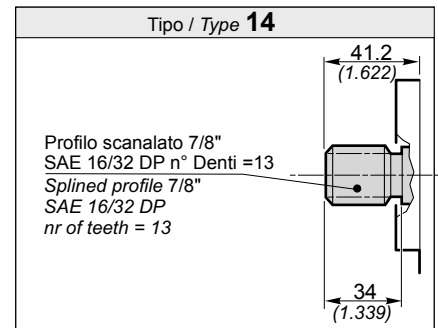
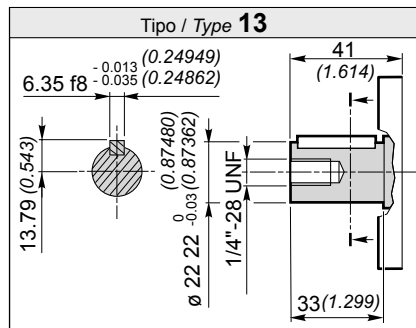
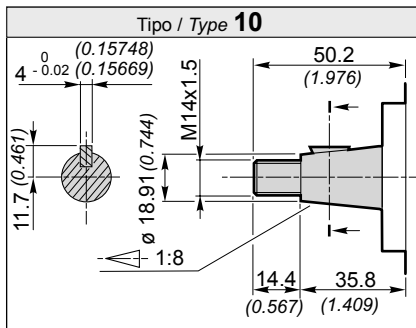

**POMPE GRUPPO
PUMPS GROUP**

3

SAE B, SAE B-OR

**Flangia e coperchio in Ghisa
Flange and cover in Cast iron**

Dati tecnici / Technical data

Grandezza Size	Cilindrata Displacement [cm ³ /rev] (in ³ /rev)	Pressione max. d'esercizio Max. working pressure			Velocità max. Max. speed [g/min] (rpm)	Portata max. Max. flow [l/min] (Gal/min)	Velocità min. Min. speed [g/min] (rpm)	Portata min. Min. flow [l/min] (Gal/min)	Dimensioni Dimensions		Massa Mass [Kg] (lbs)	Rendimento volumetrico min. Min. volumetric efficiency %
		P1 [bar] (PSI)	P2 [bar] (PSI)	P3 [bar] (PSI)					A [mm] (inch)	B [mm] (inch)		
3SP G19	19 (1.16)	270 (3915)	290 (4205)	320 (4640)	3500	66.5 (17.57)	700	12.64 (3.34)	59.4 (2.339)	125.3 (4.933)	7.59 (16.74)	95*
3SP G22	22.3 (1.36)	260 (3770)	280 (4060)	300 (4350)	3500	78 (20.61)	700	14.83 (3.92)	60.9 (2.398)	128.3 (5.051)	7.72 (17.02)	
3SP G29	29.3 (1.79)	240 (3480)	260 (3770)	280 (4060)	3300	96.7 (25.55)	700	19.48 (5.15)	63.9 (2.516)	134.3 (5.287)	8.00 (17.64)	
3SP G33	32.9 (2.01)	240 (3480)	260 (3770)	280 (4060)	3300	108.6 (28.69)	700	21.88 (5.78)	65.4 (2.575)	137.3 (5.406)	8.14 (17.95)	
3SP G36	36.4 (2.22)	230 (3335)	250 (3625)	270 (3915)	3300	120.1 (31.73)	700	24.21 (6.40)	66.9 (2.634)	140.3 (5.524)	8.27 (18.24)	
3SP G44	43.5 (2.65)	200 (2900)	220 (3190)	240 (3480)	3000	130.5 (34.48)	700	28.93 (7.64)	69.9 (2.752)	146.3 (5.760)	8.55 (18.85)	
3SP G52	51.7 (3.15)	200 (2900)	220 (3190)	240 (3480)	3000	155.1 (40.98)	700	34.38 (9.08)	73.4 (2.890)	153.3 (6.035)	8.86 (19.54)	
3SP G62	61.1 (3.73)	180 (2610)	190 (2755)	200 (2900)	2500	152.7 (40.34)	700	40.63 (10.73)	77.4 (3.047)	161.3 (6.350)	9.23 (20.35)	

* (Valori rilevati in fase di collaudo a 1500 giri/min / Value collected during the testing at 1500 rpm)

Esempio di ordinazione in codice / Example of ordering code

3SP | G | 22 | D | (H) | SAE B | - | 14 | G | (VT)

3SP	Tipo pompa / Pump type	vedi tabella / see table
G	Flangia e coperchio / Flange and cover	G = Ghisa / Cast iron
22	Cilindrata / Displacement	vedi tabella / see table
D	Rotazione destra / Clockwise rotation	D = Rotazione destra / Clockwise rotation
(H)	Anello di rinforzo per piccola pressione in aspirazione Stiffening seal for low suction pressure	S = Rotazione sinistra / Anticlockwise rotation (a richiesta / optional)
SAEB	Tipo flangia / Flange type	SAE B - SAE B - OR
-		
14	Tipo albero / Shaft type	10 - 13 - 14
G	Tipo connessioni / Connections type	G - N - W - F - T
(VT)	Opzioni / Optional	(VT) Guarnizione in Viton (a richiesta) Viton seals (optional) VLP-I (N) Valvola limitatrice di pressione (pag. A-63) Pressure relief valve (page A-63)

Conn Connessioni / Connections

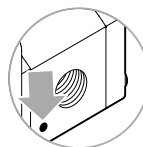
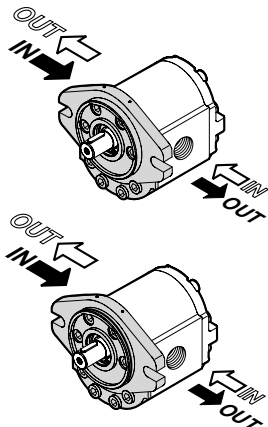
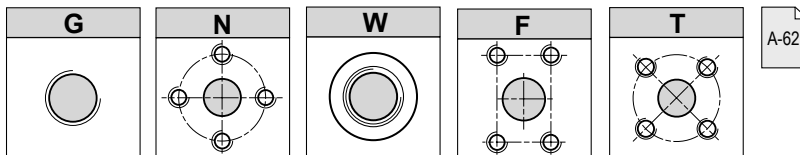

Il segno sul corpo indica il **lato aspirazione** per le pompe.
The sign on the body identify the **suction side** for the pumps.

Rotazione / Rotation	
D	S

Flangia e coperchio in Ghisa
Flange and cover in Cast iron

SAE B, SAE B-OR

POMPE GRUPPO
PUMPS GROUP

3

SAE B-OR

SAE B

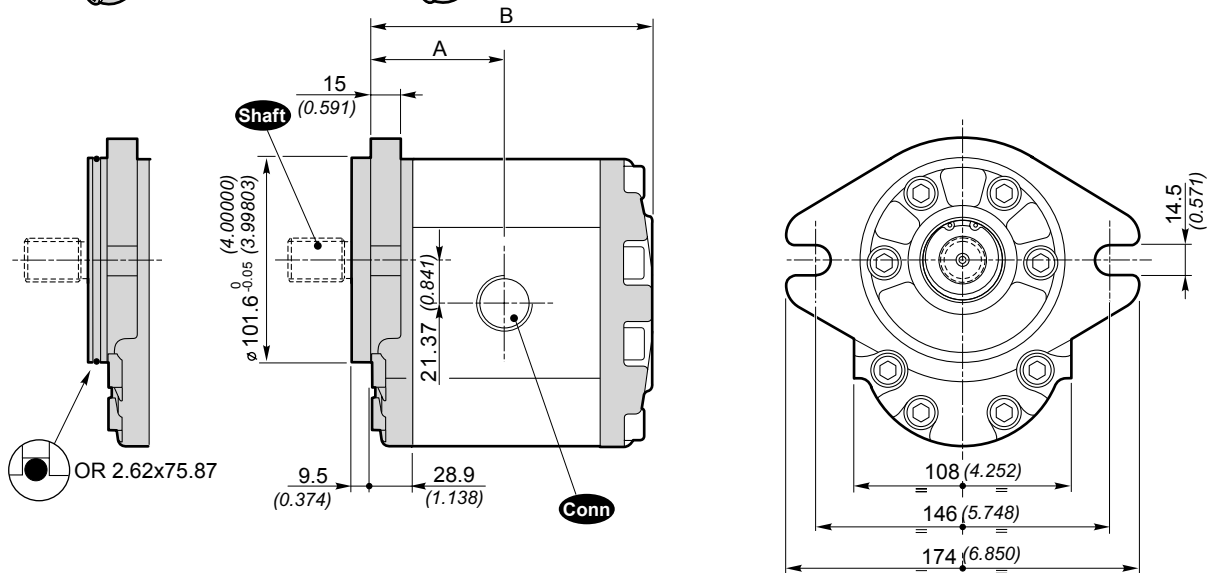
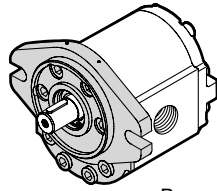
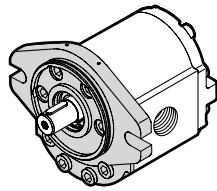

Shaft Alberi disponibili / Available shafts

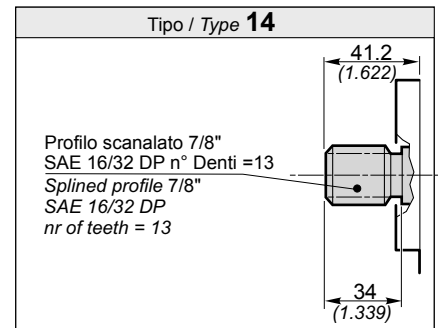
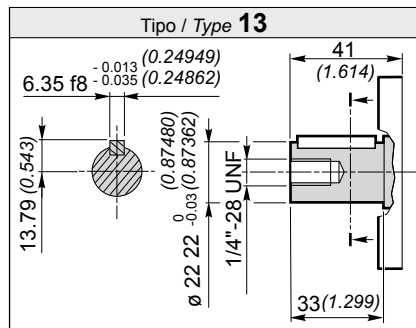
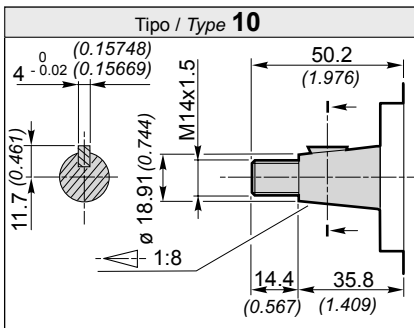

**POMPE GRUPPO
PUMPS GROUP**

3

ZFC

Dati tecnici / Technical data

Grandezza Size	Cilindrata Displacement [cm ³ /rev] (in ³ /rev)	Pressione max. d'esercizio Max. working pressure			Velocità max. Max. speed [g/min] (rpm)	Portata max. Max. flow [l/min] (Gal/min)	Velocità min. Min. speed [g/min] (rpm)	Portata min. Min. flow [l/min] (Gal/min)	Dimensioni Dimensions		Massa Mass [Kg] (lbs)	Rendimento volumetrico min. Min. volumetric efficiency %
		P1 [bar] (PSI)	P2 [bar] (PSI)	P3 [bar] (PSI)					A [mm] (inch)	B [mm] (inch)		
3SP G19	19 (1.16)	270 (3915)	290 (4205)	320 (4640)	3500	66.5 (17.57)	700	12.64 (3.34)	110.5 (4.350)	176.4 (6.945)	7.58 (16.71)	95*
3SP G22	22.3 (1.36)	260 (3770)	280 (4060)	300 (4350)	3500	78 (20.61)	700	14.83 (3.92)	112.0 (4.409)	179.4 (7.063)	7.72 (17.02)	
3SP G29	29.3 (1.79)	240 (3480)	260 (3770)	280 (4060)	3300	96.7 (25.55)	700	19.48 (5.15)	115.0 (4.528)	185.4 (7.299)	8.0 (17.64)	
3SP G33	32.9 (2.01)	240 (3480)	260 (3770)	280 (4060)	3300	108.6 (28.69)	700	21.88 (5.78)	116.5 (4.587)	188.4 (7.417)	8.14 (17.95)	
3SP G36	36.4 (2.22)	230 (3335)	250 (3625)	270 (3915)	3300	120.1 (31.73)	700	24.21 (6.40)	118.0 (4.646)	191.4 (7.535)	8.28 (18.26)	
3SP G44	43.5 (2.65)	200 (2900)	220 (3190)	240 (3480)	3000	130.5 (34.48)	700	28.93 (7.64)	121.0 (4.764)	197.4 (7.772)	8.55 (18.85)	
3SP G52	51.7 (3.15)	200 (2900)	220 (3190)	240 (3480)	3000	155.1 (40.98)	700	34.38 (9.08)	124.5 (4.902)	204.4 (8.047)	8.88 (19.58)	
3SP G62	61.1 (3.73)	180 (2610)	190 (2755)	200 (2900)	2500	152.7 (40.34)	700	40.63 (10.73)	128.5 (5.059)	212.4 (8.362)	9.25 (20.40)	

* (Valori rilevati in fase di collaudo a 1500 giri/min / Value collected during the testing at 1500 rpm)

Esempio di ordinazione in codice / Example of ordering code

3SP | G | 22 | D | ZFC | - | 24 | G | (VT)

3SP	Tipo pompa / Pump type	vedi tabella / see table
G	Flangia e coperchio / Flange and cover	G = Ghisa / Cast iron
22	Cilindrata / Displacement	vedi tabella / see table
D	Rotazione destra / Clockwise rotation	D = Rotazione destra / Clockwise rotation S = Rotazione sinistra / Anticlockwise rotation
ZFC	Tipo flangia / Flange type	SAE B - SAE B - OR
-		
14	Tipo albero / Shaft type	10 - 13 - 14
G	Tipo connessioni / Connections type	G - N - W - F - T
(VT)	Opzioni / Optional	(VT) Guarnizione in Viton (a richiesta) Viton seals (optional)

Conn Connessioni / Connections

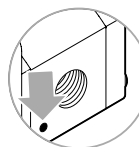
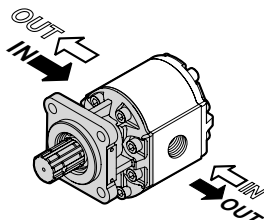
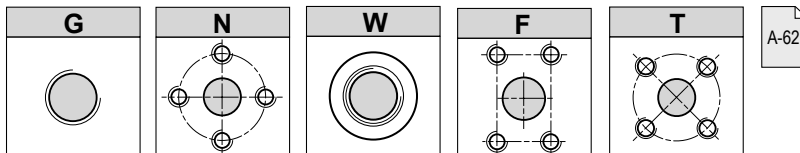

Il segno sul corpo indica il lato aspirazione per le pompe.
The sign on the body identify the suction side for the pumps.

Rotazione / Rotation	
D	S

ZFC

**POMPE GRUPPO
PUMPS GROUP**

3

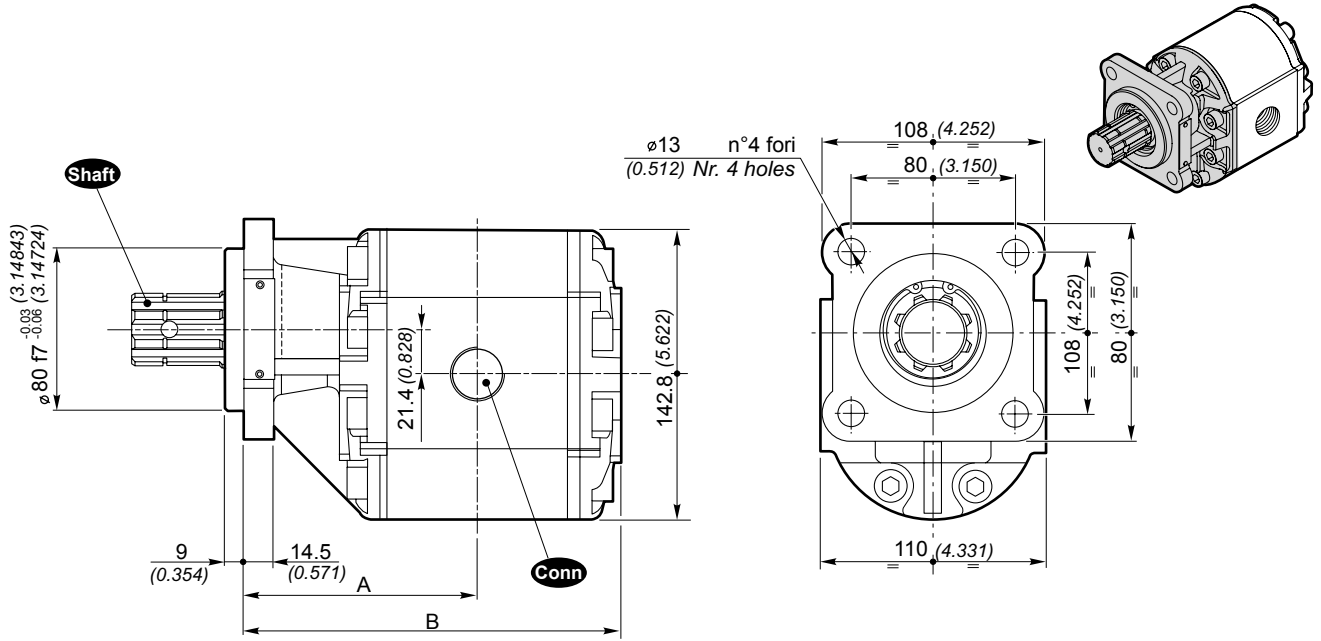

Shaft Alberi disponibili / Available shafts

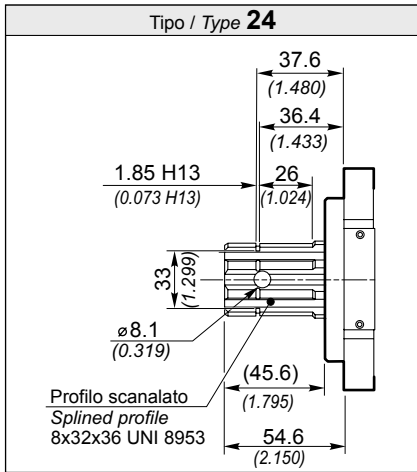

POMPE GRUPPO
PUMPS GROUP

3

CONNESSIONI / CONNECTIONS

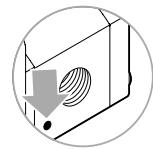
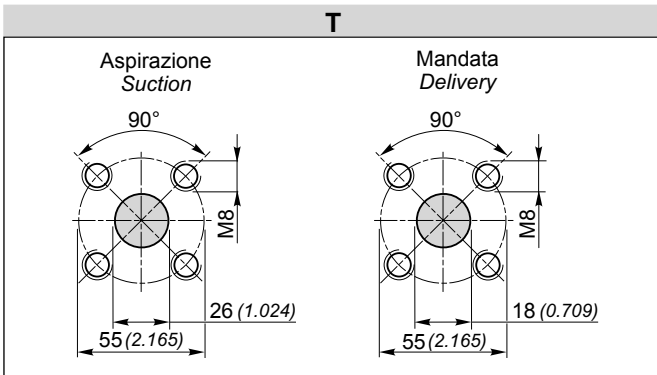
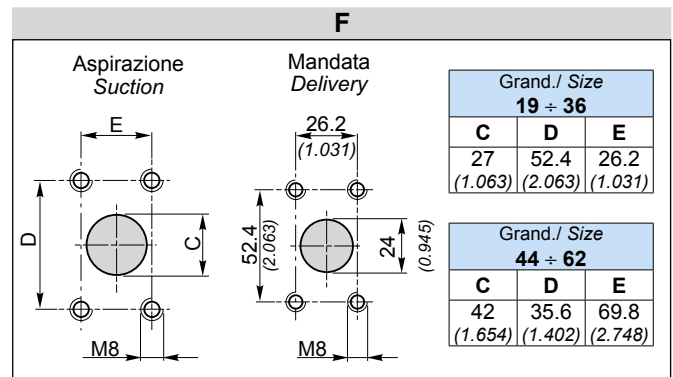
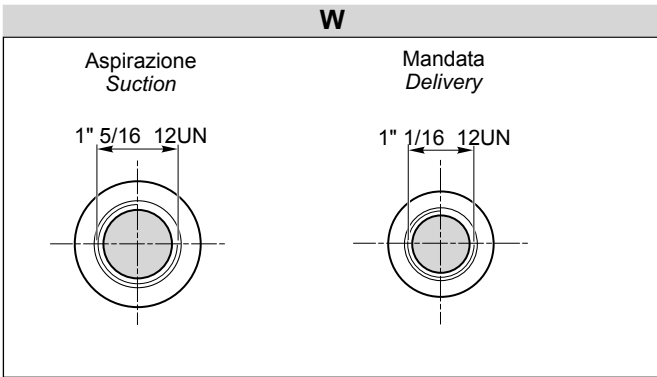
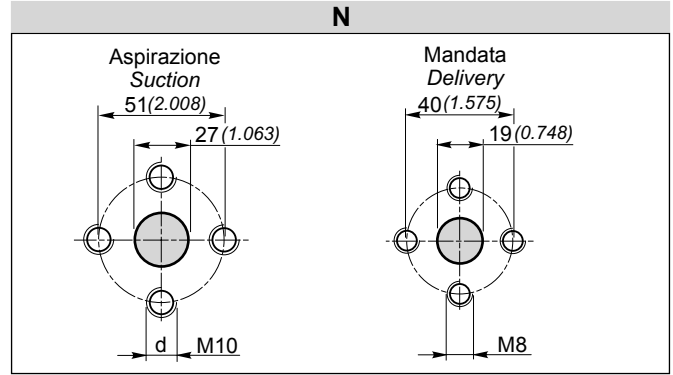
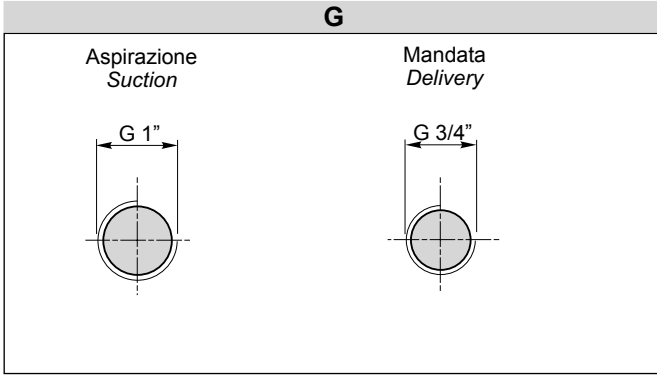

Il segno sul corpo indica il lato aspirazione per le pompe.
The sign on the body identify the suction side for the pumps.

Posizione delle connessioni / Connections positions

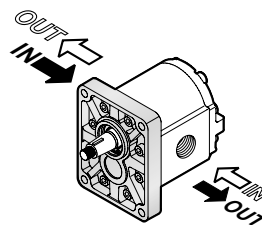

Rotazione / Rotation	
D	S

VLP- I (N)

Valvola limitatrice di pressione a scarico interno
Pressure relief valve with internal exhaust

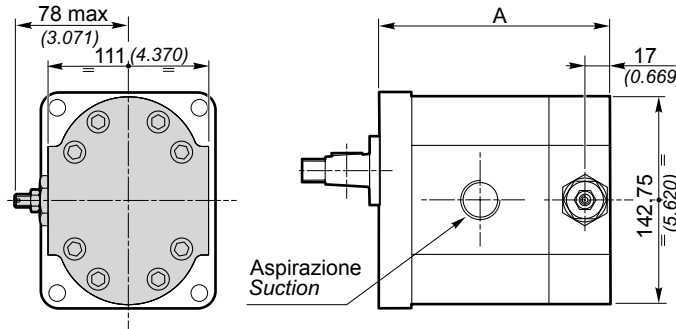
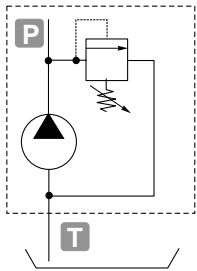
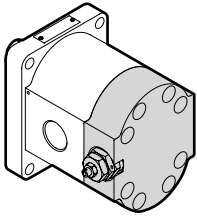

	A		
	Standard	SAE AA	E32 BX E32 CX
3SP A19	127.3 (5.012)	129.3 (5.091)	124.6 (4.906)
3SP A22	130.3 (5.130)	132.3 (5.209)	127.6 (5.024)
3SP A29	136.3 (5.366)	138.3 (5.445)	133.6 (5.260)
3SP A33	139.3 (5.484)	141.3 (5.563)	136.6 (5.378)
3SP A36	142.3 (5.602)	144.3 (5.681)	139.6 (5.496)
3SP A44	148.3 (5.839)	150.3 (5.917)	145.6 (5.732)
3SP A52	155.3 (6.114)	157.3 (6.193)	152.6 (6.008)
3SP A62	163.3 (6.429)	165.3 (6.508)	160.6 (6.323)

NB.
La valvola limitatrice di pressione si applica sostituendo il coperchio posteriore.
Fornitura solo con flangia e coperchio in Alluminio.
E' rappresentata una pompa con rotazione sinistra.

Warning.
The pressure relief valve can be applied by substituting the rear cover.
It is supplied only with aluminium flange and cover.
The showed pump is anticlockwise rotation.

L'apertura della valvola limitatrice di pressione deve avvenire per tempi non superiori ai 7 secondi ogni minuto per evitare il surriscaldamento della pompa.

The opening of the pressure relief valve should be carry out for times not over 7" each minute to avoid the overheating of the pump.

Esempio di ordinazione in codice / Example of ordering code

3SP	A	22	D	SAE B	-	10	G	(VT)	VLP-I	(N)	
VLP-I	Coperchio con VLP Cover with VLP						VPL-I (a scarico interno /at internal exhaust)				
(N)	Tipo di molla / Spring type						B - N - R (vedi tabella / See table)				

		Tipo di molla / Spring type		
		B	N	R
		molla bianca white spring	molla nera black spring	molla rossa red spring
Campi di taratura* Calibration fields*	[bar] (psi)	10 ÷ 100 (145 ÷ 1450)	30 ÷ 280 (435 ÷ 4060)	80 ÷ 380 (1160 ÷ 5510)

* In caso di omissione del valore di taratura, esso sarà inteso standard (molla nera con taratura 150 bar).

* Without setting request, it will be considered standard (black spring: 2175 psi).

**POMPE GRUPPO
PUMPS GROUP**

4

Standard

**Flangia e coperchio in Ghisa
Flange and cover in Cast iron**

Dati tecnici / Technical data

Grandezza Size	Cilindrata Displacement [cm ³ /rev] (in ³ /rev)	Pressione max. d'esercizio Max. working pressure			Velocità max. Max. speed [g/min] (rpm)	Portata max. Max. flow [l/min] (Gal/min)	Velocità min. Min. speed [g/min] (rpm)	Portata min. Min. flow [l/min] (Gal/min)	Dimensioni Dimensions		Massa Mass [Kg] (lbs)	Rendimento volumetric min. Min. volumetric efficiency %
		P1 [bar] (PSI)	P2 [bar] (PSI)	P3 [bar] (PSI)					A [mm] (inch)	B [mm] (inch)		
4SP G60	60.3 (3.68)	190 (2755)	210 (3045)	220 (3190)	2300	138.7 (36.64)	800	45.82 (12.11)	88.6 (3.488)	176.2 (6.937)	22.2 (49.0)	92*
4SP G70	69 (4.21)	180 (2610)	200 (2900)	210 (3045)	2200	151.8 (40.11)	800	52.44 (13.85)	90.6 (3.567)	180.2 (7.094)	22.7 (49.9)	
4SP G86	86 (5.25)	180 (2610)	200 (2900)	210 (3045)	2200	189.2 (49.99)	800	65.36 (17.27)	94.6 (3.724)	188.2 (7.409)	23.5 (51.8)	
4SP G103	103 (6.29)	170 (2465)	190 (2755)	200 (2900)	2000	206 (54.43)	800	78.28 (20.68)	98.6 (3.882)	196.2 (7.724)	24.3 (53.6)	
4SP G120	120 (7.32)	150 (2175)	160 (2320)	180 (2610)	2000	240 (63.41)	800	91.2 (24.10)	102.6 (4.039)	204.2 (8.039)	25.0 (55.1)	

* (Valori rilevati in fase di collaudo a 1500 giri/min / Value collected during the testing at 1500 rpm)

Esempio di ordinazione in codice / Example of ordering code

4SP | G | 60 | D | - | 10 | N | (VT)

4SP	Tipo pompa / Pump type	vedi tabella / see table
G	Flangia e coperchio / Flange and cover	G = Ghisa / Cast iron
60	Cilindrata / Displacement	vedi tabella / see table
D	Rotazione destra / Clockwise rotation	D = Rotazione destra / Clockwise rotation S = Rotazione sinistra / Anticlockwise rotation
10	Tipo albero / Shaft type	10
G	Tipo connessioni / Connections type	G - N
(VT)	Opzioni / Optional	(VT) Guarnizione in Viton (a richiesta) Viton seals (optional)

Conn Connessioni / Connections

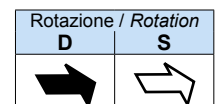
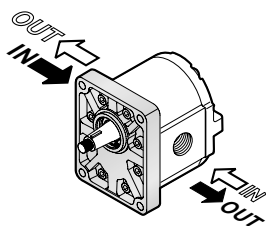
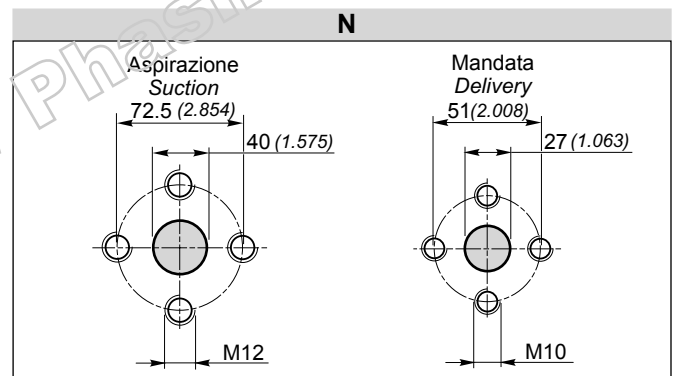
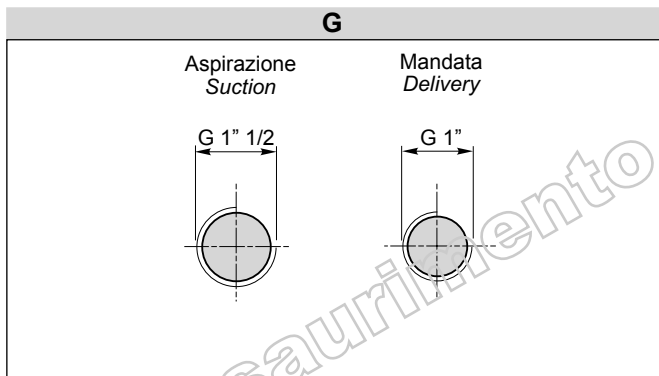

Flangia e coperchio in Ghisa
 Flange and cover in Cast iron

Standard

POMPE GRUPPO
 PUMPS GROUP

4

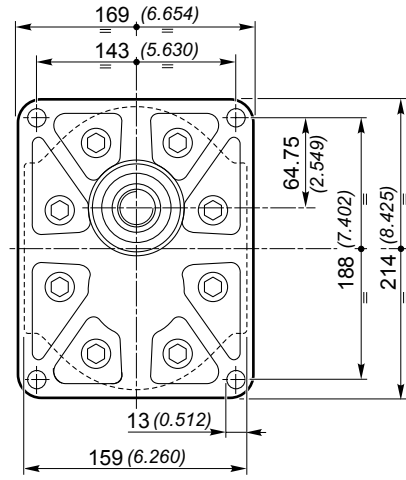
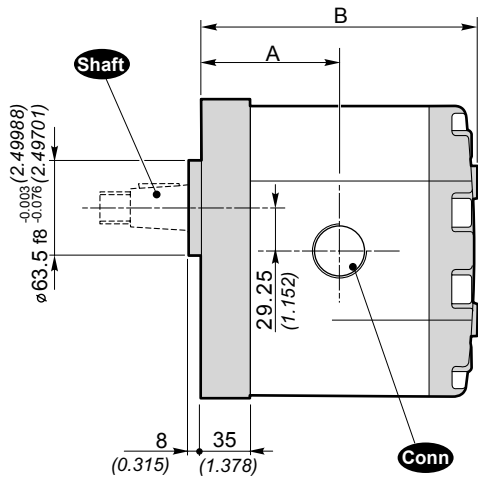
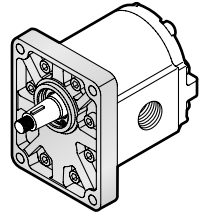

Shaft Alberi disponibili / Available shafts

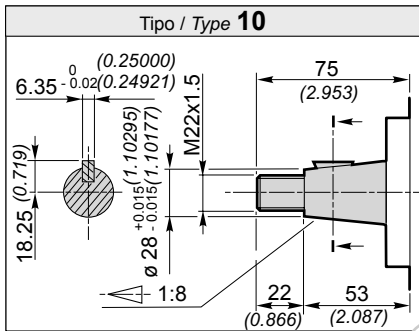

Ad esaurimento / Phasing-out

